

# AC POWER SYSTEMS HANDBOOK

---

Third Edition

---

Jerry C. Whitaker



CRC Press  
Taylor & Francis Group

[www.mepcafe.com](http://www.mepcafe.com)

[WWW.MarocEtude.Com](http://WWW.MarocEtude.Com) ---→ PORTAIL DE LA FORMATION PROFESSIONNELLE  
AU MAROC

Télécharger des livres gratuitement sur notre site, en accédant à la rubrique : [LIVRES](#)



Vous trouverez aussi sur notre site :

- Modules, Cours, Exercices à télécharger gratuitement.
- Documents Techniques dédiés à la formation professionnelle : Génie Electrique, Génie Mécanique, Génie Informatique, Génie Industriel, Génie Climatique...

*"On ne jouit bien que de ce qu'on partage"* [Madame de Genlis]

[www.mepcafe.com](http://www.mepcafe.com)

---

# AC Power Systems Handbook

## Third Edition

---

**Jerry C. Whitaker**  
Technical Press  
Morgan Hill, California



**CRC Press**  
Taylor & Francis Group  
Boca Raton London New York

CRC Press is an imprint of the  
Taylor & Francis Group, an informa business

Published in 2007 by  
CRC Press  
Taylor & Francis Group  
6000 Broken Sound Parkway NW, Suite 300  
Boca Raton, FL 33487-2742

© 2007 by Taylor & Francis Group, LLC  
CRC Press is an imprint of Taylor & Francis Group

No claim to original U.S. Government works  
Printed in the United States of America on acid-free paper  
10 9 8 7 6 5 4 3 2 1

International Standard Book Number-10: 0-8493-4034-9 (Hardcover)  
International Standard Book Number-13: 978-0-8493-4034-5 (Hardcover)  
Library of Congress Card Number 2006042620

This book contains information obtained from authentic and highly regarded sources. Reprinted material is quoted with permission, and sources are indicated. A wide variety of references are listed. Reasonable efforts have been made to publish reliable data and information, but the author and the publisher cannot assume responsibility for the validity of all materials or for the consequences of their use.

No part of this book may be reprinted, reproduced, transmitted, or utilized in any form by any electronic, mechanical, or other means, now known or hereafter invented, including photocopying, microfilming, and recording, or in any information storage or retrieval system, without written permission from the publishers.

For permission to photocopy or use material electronically from this work, please access [www.copyright.com](http://www.copyright.com) (<http://www.copyright.com/>) or contact the Copyright Clearance Center, Inc. (CCC) 222 Rosewood Drive, Danvers, MA 01923, 978-750-8400. CCC is a not-for-profit organization that provides licenses and registration for a variety of users. For organizations that have been granted a photocopy license by the CCC, a separate system of payment has been arranged.

**Trademark Notice:** Product or corporate names may be trademarks or registered trademarks, and are used only for identification and explanation without intent to infringe.

---

#### Library of Congress Cataloging-in-Publication Data

---

Whitaker, Jerry C.  
AC power systems / Jerry C. Whitaker.--3rd ed.  
p. cm.  
Includes bibliographical references and index.  
ISBN 0-8493-4034-9 (alk. paper)  
1. Electric power distribution--Alternating current--Handbooks, manuals, etc. 2. Electric power systems--Protection--Handbooks, manuals, etc. I. Title.

TK3141.W45 2006  
621.319'13--dc22

2006042620

---

**informa**  
Taylor & Francis Group  
is the Academic Division of Informa plc.

Visit the Taylor & Francis Web site at  
<http://www.taylorandfrancis.com>  
and the CRC Press Web site at  
<http://www.crcpress.com>



For Jenny and Andy,  
*very special people*

# Table of Contents

---

Preface .....	xvii
About the Author .....	xix
<b>Chapter 1 AC Power Systems</b>	
1.1 Introduction .....	1
1.1.1 Defining Terms .....	1
1.1.2 Power Electronics .....	3
1.2 AC Circuit Analysis .....	4
1.2.1 Power Relationship in AC Circuits .....	4
1.2.2 Complex Numbers .....	4
1.2.3 Phasors .....	6
1.2.4 Per Unit System .....	6
1.3 Elements of the AC Power System .....	7
1.3.1 Transmission Circuits .....	7
1.3.1.1 Types of Conductors .....	8
1.3.1.2 Overhead Conductors .....	8
1.3.1.3 Underground Cables .....	10
1.3.1.4 Skin Effect .....	10
1.3.2 Dielectrics and Insulators .....	11
1.3.2.1 Insulating Liquids .....	12
1.3.2.2 Insulating Solids .....	13
1.3.3 Control and Switching Systems .....	14
1.3.3.1 Fault Protection Devices .....	15
1.3.3.2 Lightning Arrester .....	16
1.4 Utility AC Power System Architecture .....	16
1.4.1 Power Distribution .....	18
1.4.2 Distribution Substations .....	18
1.4.2.1 Breaker Schemes .....	20
1.4.3 Voltage Analysis .....	22
1.4.4 High-Voltage DC Transmission .....	22
1.4.4.1 AC vs. DC Transmission .....	24
1.4.4.2 DC Circuit Breakers .....	25
1.4.5 Utility Company Interfacing .....	26
1.4.5.1 Phase-to-Phase Balance .....	27
1.4.6 Load Fault Protection .....	27
1.4.6.1 Fuses .....	28
1.4.6.2 Circuit Breakers .....	28
1.4.6.3 Semiconductor Fuses .....	28

	1.4.6.4 Application Considerations .....	29
	1.4.6.5 Transient Currents .....	29
	1.4.6.6 Delay-Trip Considerations .....	30
	1.4.7 Measuring AC Power .....	31
	1.4.7.1 Digital Measurement Techniques .....	32
1.5	References .....	33
1.6	Bibliography .....	34
<b>Chapter 2</b>	<b>Power-Generation Systems</b>	
2.1	Introduction .....	35
2.2	Fundamental Concepts .....	35
	2.2.1 Operating Principles .....	35
	2.2.2 Control Techniques .....	39
2.3	Power-Generating Systems .....	40
	2.3.1 Fossil Fuel Power Plants .....	40
	2.3.2 Nuclear Power Plants .....	44
	2.3.3 Hydroelectric Power Plants .....	45
2.4	References .....	48
2.5	Bibliography .....	48
<b>Chapter 3</b>	<b>Power Factor</b>	
3.1	Introduction .....	49
3.2	Fundamental Principles .....	49
3.3	PF Correction Techniques .....	52
	3.3.1 On-Site Power Factor Correction .....	53
	3.3.2 Shunt Reactors .....	55
	3.3.3 Unwanted Resonance Conditions .....	55
	3.3.4 Series Capacitor Compensation .....	56
	3.3.5 Static Compensation Devices .....	57
3.4	References .....	58
3.5	Bibliography .....	58
<b>Chapter 4</b>	<b>Power Transformers</b>	
4.1	Introduction .....	59
4.2	Inductive Properties .....	59
	4.2.1 Coils .....	60
	4.2.2 The Toroid .....	61
	4.2.3 Circuit Description of Self-Inductance .....	61
	4.2.4 Magnetic Materials .....	62
4.3	Basic Principles of the Transformer .....	62
	4.3.1 Counter-Electromotive Force .....	68
	4.3.2 Full Load Percent Impedance .....	68
	4.3.3 Design Considerations .....	69
	4.3.4 The Ideal Transformer .....	71
	4.3.5 Application Considerations .....	72
4.4	Transformer Failure Modes .....	75
	4.4.1 Thermal Considerations .....	76

	4.4.1.1 Life Expectancy and Temperature .....	76
	4.4.2 Voltage Considerations .....	76
	4.4.3 Mechanical Considerations .....	77
	4.4.3.1 Dry-Type and Liquid-Filled Transformers .....	77
	4.4.3.2 Insulation Materials .....	78
	4.4.3.3 Insulating Liquids .....	78
	4.4.3.4 Cooling .....	79
	4.5 References .....	79
	4.6 Bibliography .....	79
<b>Chapter 5</b>	<b>Capacitors</b>	
	5.1 Introduction .....	81
	5.2 Basic Principles .....	81
	5.2.1 Series and Parallel Connections .....	85
	5.2.2 Practical Capacitors .....	86
	5.3 Capacitor Failure Modes .....	86
	5.3.1 Electrolytic Capacitors .....	86
	5.3.1.1 Mechanical Failure .....	88
	5.3.1.2 Temperature Cycling .....	89
	5.3.1.3 Electrolyte Failures .....	89
	5.3.2 Capacitor Life Span .....	90
	5.3.3 Tantalum Capacitor .....	91
	5.4 References .....	91
	5.5 Bibliography .....	92
<b>Chapter 6</b>	<b>Semiconductors</b>	
	6.1 Introduction .....	93
	6.2 Semiconductor Failure Modes .....	93
	6.2.1 Device Ruggedness .....	93
	6.2.2 Forward Bias Safe Operating Area .....	94
	6.2.3 Reverse Bias Safe Operating Area .....	94
	6.2.4 Power-Handling Capability .....	95
	6.2.5 Semiconductor Derating .....	95
	6.2.6 Failure Mechanisms .....	96
	6.2.6.1 Avalanche Breakdown .....	96
	6.2.6.2 Alpha Multiplication .....	96
	6.2.6.3 Punch-Through .....	96
	6.2.6.4 Thermal Runaway .....	97
	6.3 MOSFET Devices .....	97
	6.3.1 Safe Operating Area .....	97
	6.3.2 MOSFET Failure Modes .....	101
	6.3.3 Breakdown Effects .....	101
	6.3.3.1 Thermal Second Breakdown .....	102
	6.3.3.2 Metallization Failure .....	102
	6.3.3.3 Polarity Reversal .....	102
	6.4 Thyristor Components .....	103
	6.4.1 Failure Modes .....	104
	6.4.2 Application Considerations .....	104

6.5	ESD Failure Modes .....	104
6.5.1	Failure Mechanisms .....	105
6.5.1.1	Latent Failures .....	107
6.5.1.2	Case in Point .....	107
6.6	Semiconductor Development .....	107
6.6.1	Failure Analysis .....	108
6.6.2	Chip Protection .....	111
6.7	Effects of Arcing .....	111
6.7.1	Insulation Breakdown .....	112
6.8	References .....	112
6.9	Bibliography .....	112
<b>Chapter 7 Rectifier and Filter Circuits</b>		
7.1	Introduction .....	115
7.2	Power Rectifiers .....	116
7.2.1	Operating Rectifiers in Series .....	116
7.2.2	Operating Rectifiers in Parallel .....	117
7.2.3	Silicon Avalanche Rectifiers .....	118
7.2.4	Single-Phase Rectifier Configurations .....	119
7.2.4.1	Half-Wave Rectifier .....	119
7.2.4.2	Full-Wave Rectifier .....	120
7.2.4.3	Bridge Rectifier .....	121
7.2.4.4	Voltage Multiplier .....	122
7.2.5	Polyphase Rectifier Circuits .....	122
7.3	Power Supply Filter Circuits .....	125
7.3.1	Inductive Input Filter .....	125
7.3.2	Capacitive Input Filter .....	127
7.4	References .....	129
7.5	Bibliography .....	129
<b>Chapter 8 Power Electronics</b>		
8.1	Introduction .....	131
8.2	Thyristor Devices .....	131
8.2.1	Thyristor Servo Systems .....	132
8.2.1.1	Inductive Loads .....	133
8.2.1.2	Applications .....	134
8.2.1.3	Triggering Circuits .....	137
8.2.1.4	Control Flexibility .....	139
8.2.2	Gate Turn-Off Thyristor .....	139
8.2.3	Reverse-Conducting Thyristor .....	139
8.2.4	Asymmetrical Silicon-Controlled Rectifier .....	140
8.2.5	Fusing .....	140
8.3	Power Transistors .....	140
8.3.1	Power MOSFET .....	141
8.3.1.1	Rugged MOSFET .....	141
8.3.2	Insulated-Gate Bipolar Transistor .....	142
8.3.3	MOS-Controlled Thyristor .....	143
8.4	References .....	143

8.5	Bibliography .....	143
<b>Chapter 9</b>	<b>Origins of AC Line Disturbances</b>	
9.1	Introduction .....	145
9.2	Naturally Occurring Disturbances .....	145
9.2.1	Sources of Atmospheric Energy .....	145
9.2.2	Characteristics of Lightning .....	147
9.2.2.1	Cloud-to-Cloud Activity .....	149
9.2.3	Lightning Protection .....	150
9.2.3.1	Protection Area .....	151
9.2.4	Electrostatic Discharge .....	153
9.2.4.1	Triboelectric Effect .....	154
9.2.5	EMP Radiation .....	155
9.2.6	Coupling Transient Energy .....	156
9.3	Equipment-Caused Transient Disturbances .....	157
9.3.1	Utility System Faults .....	158
9.3.2	Switch Contact Arcing .....	158
9.3.3	Telephone System Transients .....	159
9.3.4	Nonlinear Loads and Harmonic Energy .....	161
9.3.4.1	Harmonic Sources .....	164
9.3.5	Carrier Storage .....	165
9.3.6	Transient-Generated Noise .....	166
9.3.6.1	ESD Noise .....	166
9.3.6.2	Contact Arcing .....	166
9.3.6.3	SCR Switching .....	166
9.4	References .....	167
9.5	Bibliography .....	167
<b>Chapter 10</b>	<b>Power Disturbance Characterization</b>	
10.1	Introduction .....	169
10.2	Standards of Measurement .....	170
10.2.1	Assessing the Threat .....	173
10.2.2	Fundamental Measurement Techniques .....	173
10.2.2.1	Root-Mean-Square .....	173
10.2.2.2	Average-Response Measurement .....	174
10.2.2.3	Peak-Response Measurement .....	174
10.2.2.4	Meter Accuracy .....	176
10.2.3	Digital Measurement Instruments .....	177
10.2.4	Digital Monitor Features .....	178
10.3	Reliability Considerations .....	179
10.4	References .....	179
10.5	Bibliography .....	179
<b>Chapter 11</b>	<b>Power System Protection Methods</b>	
11.1	Introduction .....	181
11.2	The Key Tolerance Envelope .....	181
11.3	Assessing the Lightning Hazard .....	183
11.4	FIPS Publication 94 .....	184
11.5	Protection Alternatives .....	185

11.5.1	Specifying System-Protection Hardware .....	187
11.6	References .....	189
11.7	Bibliography .....	189
<b>Chapter 12</b>	<b>Motor-Generator Set</b>	
12.1	Introduction .....	191
12.2	System Configuration .....	191
12.2.1	Motor Design Considerations .....	194
12.2.1.1	Single-Shaft Systems .....	195
12.2.2	Flywheel Considerations .....	196
12.2.3	Maintenance Considerations .....	197
12.2.4	Motor-Generator UPS .....	197
12.2.5	Kinetic Battery Storage System .....	199
12.3	References .....	201
12.4	Bibliography .....	201
<b>Chapter 13</b>	<b>Uninterruptible Power Systems</b>	
13.1	Introduction .....	203
13.2	UPS Configuration .....	203
13.2.1	Power-Conversion Methods .....	205
13.2.1.1	Ferroresonant Inverter .....	205
13.2.1.2	Delta Magnetic Inverter .....	206
13.2.1.3	Inverter-Fed L/C Tank .....	207
13.2.1.4	Quasi-Square Wave Inverter .....	207
13.2.1.5	Step Wave Inverter .....	209
13.2.1.6	Pulse-Width Modulation Inverter .....	209
13.2.1.7	Phase Modulation Inverter .....	209
13.2.2	Redundant Operation .....	209
13.2.3	Output Transfer Switch .....	212
13.2.4	Battery Supply .....	213
13.3	References .....	213
13.4	Bibliography .....	213
<b>Chapter 14</b>	<b>Power Conditioning Devices</b>	
14.1	Introduction .....	215
14.2	Ferroresonant Transformer .....	215
14.2.1	Magnetic-Coupling-Controlled Voltage Regulator .....	216
14.3	Isolation Transformer .....	217
14.3.1	Tap-Changing Regulator .....	219
14.3.1.1	Variable Ratio Regulator .....	220
14.3.2	Variable Voltage Transformer .....	221
14.3.2.1	Brush Type .....	222
14.3.2.2	Induction Type .....	222
14.4	Line Conditioner .....	222
14.4.1	Hybrid Transient Suppressor .....	224
14.4.2	Active Power-Line Conditioner .....	224
14.4.2.1	Application Considerations .....	226
14.5	References .....	226
14.6	Bibliography .....	226

<b>Chapter 15</b>	<b>Transient-Suppression Devices</b>	
15.1	Introduction .....	227
15.2	Filter Devices .....	227
15.3	Crowbar Devices .....	229
15.3.1	Characteristics of Arcs .....	229
15.4	Voltage-Clamping Devices .....	229
15.4.1	Zener Components .....	234
15.4.2	Hybrid Suppression Circuits .....	237
15.5	Selecting Protection Components .....	238
15.6	References .....	238
15.7	Bibliography .....	239
<b>Chapter 16</b>	<b>Facility Wiring and Transient Protection</b>	
16.1	Introduction .....	241
16.2	Facility Wiring .....	241
16.2.1	Utility Service Entrance .....	243
16.3	Power-System Protection .....	245
16.3.1	Staging .....	245
16.3.2	Design Cautions .....	248
16.3.2.1	Specifications .....	248
16.3.3	Single-Phasing .....	249
16.3.4	Surge Suppressor Selection .....	249
16.4	References .....	251
16.5	Bibliography .....	251
<b>Chapter 17</b>	<b>Circuit-Level Transient Suppression</b>	
17.1	Introduction .....	253
17.2	Protecting Low-Voltage Supplies .....	253
17.3	Protecting High-Voltage Supplies .....	253
17.4	RF System Protection .....	257
17.5	Protecting Logic Circuits .....	257
17.6	Protecting Telco Lines .....	258
17.7	Inductive Load Switching .....	261
17.8	Bibliography .....	261
<b>Chapter 18</b>	<b>Grounding Practices</b>	
18.1	Introduction .....	263
18.1.1	Terms and Codes .....	263
18.2	The Need for Grounding .....	263
18.2.1	Equipment Grounding .....	264
18.2.2	System Grounding .....	264
18.2.3	The Grounding Electrode .....	267
18.2.4	Earth Electrode .....	268
18.3	Establishing an Earth Ground .....	268
18.3.1	Grounding Interface .....	268
18.3.1.1	Ground Electrode Testing .....	273
18.3.2	Chemical Ground Rods .....	273
18.3.3	Ufer Ground System .....	274
18.3.4	Bonding Ground-System Elements .....	277



18.3.5	Exothermic Bonding .....	277
18.3.6	Ground-System Inductance .....	278
18.4	References .....	280
18.5	Bibliography .....	281
<b>Chapter 19</b>	<b>Grounding Tower Elements</b>	
19.1	Introduction .....	283
19.2	Ground-Wire Dressing .....	283
19.3	Facility Ground Interconnection .....	284
19.3.1	Personnel Protection .....	285
19.4	Grounding on Bare Rock .....	288
19.4.1	Rock-Based Radial Elements .....	288
19.5	Transmission-System Grounding .....	289
19.5.1	Transmission Line .....	289
19.5.2	Cable Considerations .....	289
19.5.3	Satellite Antenna Grounding .....	290
19.6	References .....	292
<b>Chapter 20</b>	<b>Facility Ground-System Design</b>	
20.1	Introduction .....	293
20.2	Bulkhead Grounding .....	293
20.2.1	Bulkhead Panel .....	297
20.2.2	Lightning Protectors .....	299
20.2.2.1	Typical Installation .....	300
20.2.3	Checklist for Proper Grounding .....	302
20.3	AC System Grounding Practices .....	303
20.3.1	Building Codes .....	303
20.3.1.1	Single-Point Ground .....	304
20.3.2	Isolated Grounding .....	304
20.3.3	Separately Derived Systems .....	305
20.3.4	Grounding Terminology .....	305
20.3.5	Facility Ground System .....	306
20.3.5.1	Grounding Conductor Size .....	309
20.3.5.2	High-Frequency Effects .....	311
20.3.6	Power-Center Grounding .....	311
20.3.6.1	Isolation Transformers .....	313
20.4	Grounding Equipment Racks .....	314
20.5	Grounding Signal Cables .....	316
20.5.1	Analyzing Noise Currents .....	316
20.5.2	Types of Noise .....	317
20.5.3	Noise Control .....	318
20.6	Patch-Bay Grounding .....	320
20.7	Cable Routing .....	321
20.7.1	Overcoming Ground-System Problems .....	322
20.8	References .....	322
20.9	Bibliography .....	322
<b>Chapter 21</b>	<b>Standby Power Systems</b>	
21.1	Introduction .....	325

21.1.1	Blackout Effects .....	325
21.2	Standby Power Options .....	326
21.2.1	Dual-Feeder System .....	326
21.2.2	Peak Power Shaving .....	328
21.2.3	Advanced System Protection .....	329
21.2.4	Choosing a Generator .....	329
21.2.4.1	Generator Types .....	332
21.2.5	UPS Systems .....	333
21.2.6	Standby Power-System Noise .....	333
21.2.7	Batteries .....	334
21.2.7.1	Terms .....	334
21.2.7.2	Sealed Lead-Acid Battery .....	335
21.3	References .....	336
21.4	Bibliography .....	336
<b>Chapter 22</b>	<b>Designing for Fault-Tolerance</b>	
22.1	Introduction .....	337
22.2	Critical System Bus .....	337
22.2.1	Power-Distribution Options .....	338
22.2.2	Plant Configuration .....	340
22.3	Plant Maintenance .....	341
22.3.1	Switchgear Maintenance .....	342
22.3.2	Ground-System Maintenance .....	342
22.4	References .....	344
22.5	Bibliography .....	344
<b>Chapter 23</b>	<b>The Efficient Use of Energy</b>	
23.1	Introduction .....	345
23.2	Energy Usage .....	345
23.3	Peak Demand .....	346
23.4	Load Factor .....	347
23.5	Power Factor .....	347
23.6	References .....	349
23.7	Bibliography .....	349
<b>Chapter 24</b>	<b>Safety and Protection Systems</b>	
24.1	Introduction .....	351
24.1.1	Facility Safety Equipment.....	351
24.2	Electric Shock .....	353
24.2.1	Effects on the Human Body .....	353
24.2.2	Circuit-Protection Hardware .....	355
24.2.3	Working with High Voltage .....	358
24.2.4	First Aid Procedures .....	358
24.2.4.1	Shock in Progress .....	360
24.2.4.2	Shock No Longer in Progress .....	360
24.3	Polychlorinated Biphenyls .....	361
24.3.1	Health Risk .....	361
24.3.2	Governmental Action .....	362
24.3.3	PCB Components .....	362

24.3.4	Identifying PCB Components .....	364
24.3.5	Labeling PCB Components .....	364
24.3.6	Record-Keeping .....	365
24.3.7	Disposal .....	366
24.3.8	Proper Management .....	366
24.4	OSHA Safety Requirements .....	367
24.4.1	Protective Covers .....	368
24.4.2	Identification and Marking .....	368
24.4.3	Extension Cords .....	368
24.4.4	Grounding .....	368
24.4.5	Management Responsibility .....	369
24.5	References .....	371
24.6	Bibliography .....	371
<b>Chapter 25 Reference Data and Tables</b>		
25.1	Standard Electrical Units .....	373
25.1.1	Standard Prefixes .....	374
25.1.2	Common Standard Units .....	375
25.2	Reference Tables .....	376
25.2.1	Power Conversion Factors .....	376
25.2.2	Standing Wave Ratio .....	377
25.2.3	Specifications of Standard Copper Wire Sizes .....	378
25.2.4	Celsius-to-Fahrenheit Conversion Table .....	379
25.2.5	Inch-to-Millimeter Conversion Table .....	380
25.2.6	Conversion of Millimeters to Decimal Inches .....	381
25.2.7	Conversion of Common Fractions to Decimal and Millimeter Units .....	382
25.2.8	Decimal Equivalent Size of Drill Numbers .....	383
25.2.9	Decimal Equivalent Size of Drill Letters .....	383
25.2.10	Conversion Ratios for Length .....	384
25.2.11	Conversion Ratios for Area .....	384
25.2.12	Conversion Ratios for Mass .....	385
25.2.13	Conversion Ratios for Volume .....	385
25.2.14	Conversion Ratios for Cubic Measure .....	386
25.2.15	Conversion Ratios for Electrical Quantities .....	386
<b>Chapter 26 Units Conversion Table</b>		
26.1	Quantity Conversion .....	387

# Preface

---

Disturbances on the ac power line are what headaches are made of. Outages, surges, sags, transients: they combine to create an environment that can damage or destroy sensitive load equipment. They can take your system down and leave you with a complicated and expensive repair job.

Ensuring that the equipment at your facility receives clean ac power has always been important. But now, with computers integrated into a wide variety of electronic products, the question of ac power quality is more critical than ever. The computer-based systems prevalent today can garble or lose data because of power-supply disturbances or interruptions. And if the operational problems are not enough, there is the usually difficult task of equipment troubleshooting and repair that follows a utility system fault.

This book examines the key elements of ac power use for commercial and industrial customers. The roots of ac power-system problems are identified, and effective solutions are detailed. The book follows a logical progression from generating ac energy to the protection of life and property. General topics include:

- **Power-System Operation.** Every electronic installation requires a steady supply of clean power to function properly. The ac power line into a facility is, in fact, the lifeblood of any operation. It is also, however, a frequent source of equipment malfunctions and component failures. This book details the process of generating ac energy and distributing it to end-users. The causes of power-system disturbances are detailed, and the characteristics of common fault conditions are outlined.
- **Protecting Equipment Loads.** Power quality is a moving target. Utility companies work hard to maintain acceptable levels of performance. However, the wide variety of loads and unpredictable situations make this job difficult. Users cannot expect power suppliers to solve all their problems. Responsibility for protecting sensitive loads clearly rests with the end-user. Several chapters are devoted to this important topic. Power-system protection options are outlined, and their relative benefits discussed. Evaluating the many tradeoffs involved in protection system design requires a thorough knowledge of the operating principles.
- **How Much Protection?** The degree of protection afforded a facility is generally a compromise between the line abnormalities that will account for most of the expected problems and the amount of money available to spend on that protection. Each installation is unique and requires an assessment of the importance of keeping the system up and running at all times, as well as the threat of disturbances posed by the ac feed to the plant. The author firmly believes that the degree of protection provided a power-distribution system should match the threat of system failure. In this publication, all alternatives are examined with an eye toward deciding how much protection really is needed, and how much money can be justified for ac protection hardware.
- **Grounding.** The attention given to the design and installation of a facility ground system is a key element in the day-to-day reliability of any plant. A well-planned ground network is invisible to the

engineering staff. A marginal ground system, however, will cause problems on a regular basis. Although most engineers view grounding primarily as a method to protect equipment from damage or malfunction, the most important element is operator safety. The 120 V or 208 V ac line current that powers most equipment can be dangerous — even deadly — if improperly handled. Grounding of equipment and structures provides protection against wiring errors or faults that could endanger human life. Grounding concepts and practices are examined in detail. Clear, step-by-step guidelines are given for designing and installing an effective ground system to achieve good equipment performance, and to provide for operator safety.

- **Standby Power.** Blackouts are, without a doubt, the most troublesome utility company problem that a facility will have to deal with. Statistics show that power failures are, generally speaking, a rare occurrence in most areas of the country. They also are usually short in duration. Typical failure rates are not normally cause for alarm to commercial users, except where computer-based operations, transportation control systems, medical facilities, and communications sites are concerned. When the continuity of operation is critical, redundancy must be carried throughout the system. All of the practical standby power systems are examined in this book. The advantages and disadvantages of each approach are given, and examples are provided of actual installations.
- **Safety.** Safety is critically important to engineering personnel who work around powered hardware, and who may work under time pressures. Safety is not something to be taken lightly. The voltages contained in the ac power system are high enough to kill through electrocution. The author takes safety seriously. A full chapter is devoted to the topic. Safety requires not only the right equipment, but operator training as well. Safety is, in the final analysis, a state of mind.

The utility company ac feed contains not only the 60 Hz power needed to run the facility, but also a variety of voltage disturbances, which can cause problems ranging from process control interruptions to life-threatening situations. Protection against ac line disturbances is a science that demands attention to detail. This work is not inexpensive. It is not something that can be accomplished overnight. Facilities will, however, wind up paying for protection one way or another, either before or after problems occur. Power protection is a *systems problem* that extends from the utility company ac input to the circuit boards in each piece of hardware. There is nothing magical about effective systems protection. Disturbances on the ac line can be suppressed if the protection method used has been designed carefully and installed properly. That is the goal of this book.

*Jerry C. Whitaker*

# About the Author

---

**Jerry C. Whitaker** is vice president of standards development at the Advanced Television Systems Committee (ATSC). Mr. Whitaker supports the work of the various ATSC technology and planning committees and assists in the development of ATSC standards, recommended practices, and related documents. ATSC is an international, nonprofit organization developing voluntary standards for digital television.

Mr. Whitaker is a fellow of the Society of Broadcast Engineers and an SBE-certified professional broadcast engineer. He is also a fellow of the Society of Motion Picture and Television Engineers, and a member of the Institute of Electrical and Electronics Engineers.

Mr. Whitaker has been involved in various aspects of the electronics industry for over 30 years. Current CRC book titles include:

- *The Electronics Handbook*, 2nd edition
- *Electronic System Maintenance Handbook*, 2nd edition
- *Power Vacuum Tubes Handbook*, 2nd edition
- *The RF Transmission Systems Handbook*
- *Microelectronics*, 2nd edition

Mr. Whitaker has lectured extensively on the topic of electronic systems design, installation, and maintenance. He is the former editorial director and associate publisher of *Broadcast Engineering* and *Video Systems* magazines, and a former radio station chief engineer and television news producer.

Mr. Whitaker has twice received a Jesse H. Neal Award Certificate of Merit from the Association of Business Publishers for editorial excellence. He has also been recognized as educator of the year by the Society of Broadcast Engineers.

Mr. Whitaker resides in Morgan Hill, California.

# AC Power Systems

---

## 1.1 Introduction

---

Every electronic installation requires a steady supply of clean power to function properly. Recent advances in technology have made the question of alternating current (ac) power quality even more important, as microcomputers are integrated into a wide variety of electronic products.

When the subject of power quality is discussed, the mistaken assumption is often made that the topic only has to do with computers. At one time this may have been true, because data processing (DP) centers were among the first significant loads that did not always operate reliably on the raw power received from the serving electrical utility. With the widespread implementation of control by microprocessor-based single-board computers (or single-chip computers), however, there is a host of equipment that now operates at voltage levels and clock speeds similar to that of the desktop or mainframe computer. Equipment as diverse as electronic instrumentation, cash registers, scanners, motor drives, and television sets all depend upon onboard computers to give them instructions. Thus, the quality of the power this equipment receives is as important as that supplied to a data processing center. The broader category, which covers all such equipment, including computers, is perhaps best described as *sensitive electronic equipment*.

The heart of the problem that seems to have suddenly appeared is that although the upper limit of circuit speed of modern digital devices is continuously being raised, the logic voltages have simultaneously been reduced. Such a relationship is not accidental. As more transistors and other devices are packed together onto the same surface area, the spacing between them is necessarily reduced. This reduced distance between components tends to lower the time the circuit requires to perform its designed function. A reduction in the operating voltage level is a necessary — and from the standpoint of overall performance, particularly heat dissipation, desirable — by-product of the shrinking integrated circuit (IC) architectures.

The ac power line into a facility is, of course, the lifeblood of any operation. It is also, however, a frequent source of equipment malfunctions and component failures. The utility company ac feed contains not only the 60 Hz power needed to run the facility, but also a variety of voltage sags, surges, and transients. These abnormalities cause different problems for different types of equipment.

### 1.1.1 Defining Terms

To explain the ac power-distribution system, and how to protect sensitive loads from damage resulting from disturbances, it is necessary first to define key terms:

- *active filter*. A switching power processor connected between the line and a nonlinear load, with the purpose of reducing the harmonic currents generated by the load.
- *alternator*. An ac generator.
- *boost rectifier*. An unfiltered rectifier with a voltage-boosting direct current (dc)/dc converter between it and the load that shapes the line current to maintain low distortion.
- *circular mil*. The unit of measurement for current-carrying conductors. One mil is equal to 0.001 in. (0.025 mm). One circular mil is equal to a circle with a diameter of 0.001 in. The area of a circle with a 1-in. diameter is 1,000,000 circular mils.
- *common-mode noise*. Unwanted signals in the form of voltages appearing between the local ground reference and each of the power conductors, including neutral and the equipment ground.
- *cone of protection* (lightning). The space enclosed by a cone formed with its apex at the highest point of a lightning rod or protecting tower, the diameter of the base of the cone having a definite relationship to

the height of the rod or tower. When overhead ground wires are used, the space protected is referred to as a *protected zone*.

- *cosmic rays*. Charged particles (ions) emitted by all radiating bodies in space.
- *Coulomb*. A unit of electric charge. The coulomb is the quantity of electric charge that passes the cross section of a conductor when the current is maintained constant at 1 A.
- *counter-electromotive force*. The effective electromotive force within a system that opposes the passage of current in a specified direction.
- *counterpoise*. A conductor or system of conductors arranged (typically) below the surface of the earth and connected to the footings of a tower or pole to provide grounding for the structure.
- *demand meter*. A measuring device used to monitor the power demand of a system; it compares the peak power of the system with the average power.
- *dielectric* (ideal). An insulating material in which all of the energy required to establish an electric field in the dielectric is recoverable when the field or impressed voltage is removed. A perfect dielectric has zero conductivity, and all absorption phenomena are absent. A complete vacuum is the only known perfect dielectric.
- *eddy currents*. The currents that are induced in the body of a conducting mass by the time variations of magnetic flux.
- *efficiency* (electric equipment). Output power divided by input power, expressed as a percentage.
- *electromagnetic compatibility* (EMC). The ability of a device, piece of equipment, or system to function satisfactorily in its electromagnetic environment without introducing intolerable electromagnetic disturbances.
- *generator*. A machine that converts mechanical power into electrical power. (In this book, the terms *alternator* and *generator* will be used interchangeably.)
- *grid stability*. The capacity of a power distribution grid to supply the loads at any node with stable voltages; its opposite is *grid instability*, manifested by irregular behavior of the grid voltages at some nodes.
- *ground loop*. Sections of conductors shared by two different electronic or electric circuits, usually referring to circuit return paths.
- *horsepower*. The basic unit of mechanical power. One horsepower (hp) equals 550 foot-pounds per second or 746 watts.
- *HVAC*. Abbreviation for heating, ventilation, and air-conditioning system.
- *hysteresis loss* (magnetic, power, and distribution transformer). The energy loss in magnetic material that results from an alternating magnetic field as the elementary magnets within the material seek to align themselves with the reversing field.
- *impedance*. A linear operator expressing the relationship between voltage and current. The inverse of impedance is *admittance*.
- *induced voltage*. A voltage produced around a closed path or circuit by a time rate of change in a magnetic flux linking that path when there is no relative motion between the path or circuit and the magnetic flux.
- *joule*. A unit of energy equal to 1 watt-second.
- *life safety system*. System designed to protect life and property, such as emergency lighting, fire alarms, smoke exhaust and ventilating fans, and site security.
- *lightning flash*. An electrostatic atmospheric discharge. The typical duration of a lightning flash is approximately 0.5 scc. A single flash is made up of various discharge components, usually including three or four high-current pulses called *strokes*.
- *metal-oxide varistor*. A solid-state voltage-clamping device used for transient-suppression applications.
- *normal-mode noise*. Unwanted signals in the form of voltages appearing in line-to-line and line-to-neutral signals.
- *permeability*. A general term used to express relationships between magnetic induction and magnetizing force. These relationships are either (1) *absolute permeability*, which is the quotient of a change in



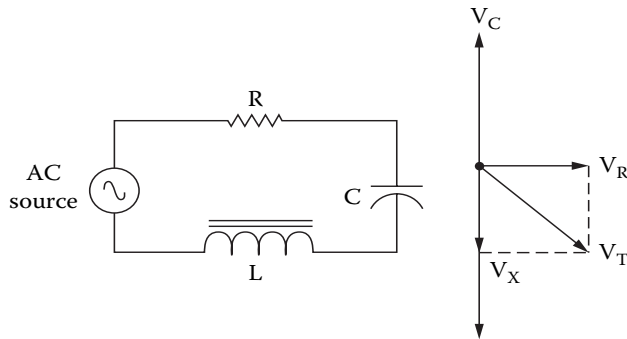
- magnetic induction divided by the corresponding change in magnetizing force, or (2) *specific* (relative) *permeability*, which is the ratio of absolute permeability to the magnetic constant.
- *point of common coupling* (PCC). The point at which the utility and the consumer's power systems are connected (usually where the energy meter is located).
  - *power factor* (PF). The ratio of total watts to the total root-mean-square (rms) volt-amperes in a given circuit. Power factor =  $W/VA$ .
  - *power quality*. The degree to which the utility voltage approaches the ideal case of a stable, uninterrupted, zero-distortion, and disturbance-free source.
  - *radio frequency interference*. Noise resulting from the interception of transmitted radio frequency energy.
  - *reactance*. The imaginary part of impedance.
  - *reactive power*. The quantity of unused power that is developed by reactive components (inductive or capacitive) in an ac circuit or system.
  - *safe operating area*. A semiconductor device parameter, usually provided in chart form, that outlines the maximum permissible limits of operation.
  - *saturation* (in a transformer). The maximum intrinsic value of induction possible in a material.
  - *self-inductance*. The property of an electric circuit whereby a change of current induces an electromotive force in that circuit.
  - *single-phasing*. A fault condition in which one of the three legs in a three-phase power system becomes disconnected, usually because of an open fuse or fault condition.
  - *solar wind*. Charged particles from the sun that continuously bombard the surface of the earth.
  - *switching power supply*. Any type of ac/ac, ac/dc, dc/ac, or dc/dc power converter using periodically operated switching elements. Energy-storage devices (capacitors and inductors) are usually included in such supplies.
  - *transient disturbance*. A voltage pulse of high energy and short duration impressed upon the ac waveform. The overvoltage pulse may be 1 to 100 times the normal ac potential (or more in some cases) and may last up to 15 ms. Rise times typically measure in the nanosecond range.
  - *uninterruptible power system* (UPS). An ac power-supply system that is used for computers and other sensitive loads to (1) protect the load from power interruptions, and (2) protect the load from transient disturbances.
  - *VAR compensator*. A switching power processor, operating at the line frequency, with the purpose of reducing the reactive power being produced by a piece of load equipment.
  - *voltage regulation*. The deviation from a nominal voltage, expressed as a percentage of the nominal voltage.

### 1.1.2 Power Electronics

*Power electronics* is a multidisciplinary technology that encompasses power semiconductor devices, converter circuits, electrical machines, signal electronics, control theory, microcomputers, very-large-scale integration (VLSI) circuits, and computer-aided design techniques. Power electronics in its present state has been possible as a consequence of a century of technological evolution. In the late 19th and early 20th centuries, the use of rotating machines for power control and conversion was well known [1]. Popular examples are the Ward Leonard speed control of dc motors and the Kramer and Scherbius drives of wound rotor induction motors.

The history of power electronics began with the introduction of the glass bulb mercury arc rectifier in 1900 [2]. Gradually, metal tank rectifiers, grid-controlled rectifiers, ignitions, phanotrons, and thyratrons were introduced. During World War II, magnetic amplifiers based on saturable core reactors and selenium rectifiers became especially attractive because of their ruggedness, reliability, and radiation-hardened characteristics.

Possibly the greatest revolution in the history of electrical engineering occurred with the invention of the transistor by Bardeen, Brattain, and Shockley at the Bell Telephone Laboratories in 1948. In 1956,



**Figure 1.1** Voltage vectors in a series RLC circuit.

the same laboratory invented the PNPN triggering transistor, which later came to be known as the thyristor or silicon controlled rectifier (SCR). In 1958, the General Electric Company introduced the first commercial thyristor, marking the beginning of the modern era of power electronics. Many different types of power semiconductor devices have been introduced since that time, further pushing the limits of operating power and efficiency, and long-term reliability.

It is interesting to note that in modern power electronics systems, there are essentially two types of semiconductor elements: the power semiconductors, which can be regarded as the muscle of the equipment, and the microelectronic control chips, which make up the brain. Both are digital in nature, except that one manipulates power up to gigawatt levels and the other deals with milliwatts or microwatts. Today's power electronics systems integrate both of these end-of-the-spectrum devices, providing large size and cost advantages, and intelligent operation.

## 1.2 AC Circuit Analysis

Vectors are used commonly in ac circuit analysis to represent voltage or current values. Rather than using waveforms to show phase relationships, it is accepted practice to use vector representations (sometimes called *phasor diagrams*). To begin a vector diagram, a horizontal line is drawn, its left end being the *reference point*. Rotation in a counterclockwise direction from the reference point is considered to be positive. Vectors may be used to compare voltage drops across the components of a circuit containing resistance, inductance, or capacitance. Figure 1.1 shows the vector relationship in a series RLC circuit, and Figure 1.2 shows a parallel RLC circuit.

### 1.2.1 Power Relationship in AC Circuits

In a dc circuit, power is equal to the product of voltage and current. This formula also is true for purely resistive ac circuits. However, when a reactance — either inductive or capacitive — is present in an ac circuit, the dc power formula does not apply. The product of voltage and current is, instead, expressed in volt-amperes (VA) or kilovoltamperes (kVA). This product is known as the *apparent power*. When meters are used to measure power in an ac circuit, the apparent power is the voltage reading multiplied by the current reading. The actual power that is converted to another form of energy by the circuit is measured with a wattmeter, and is referred to as the *true power*. In ac power-system design and operation, it is desirable to know the ratio of true power converted in a given circuit to the apparent power of the circuit. This ratio is referred to as the power factor.

### 1.2.2 Complex Numbers

A complex number is represented by a *real part* and an *imaginary part*. For example, in  $A = a + jb$ ,  $A$  is the complex number;  $a$  is real part, sometimes written as  $\text{Re}(A)$  and  $b$  is the imaginary part of  $A$ , often

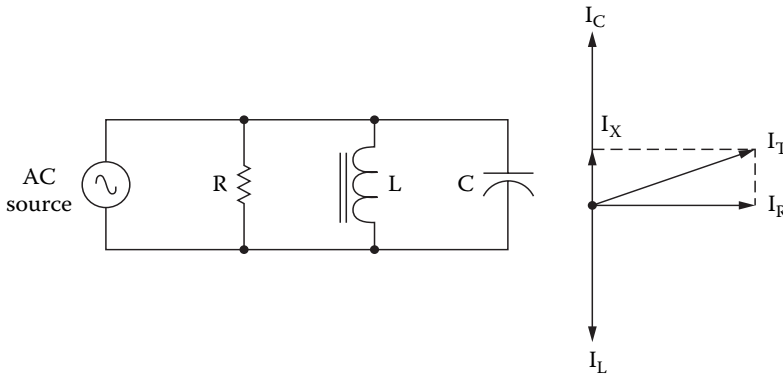


Figure 1.2 Current vectors in a parallel RLC circuit.

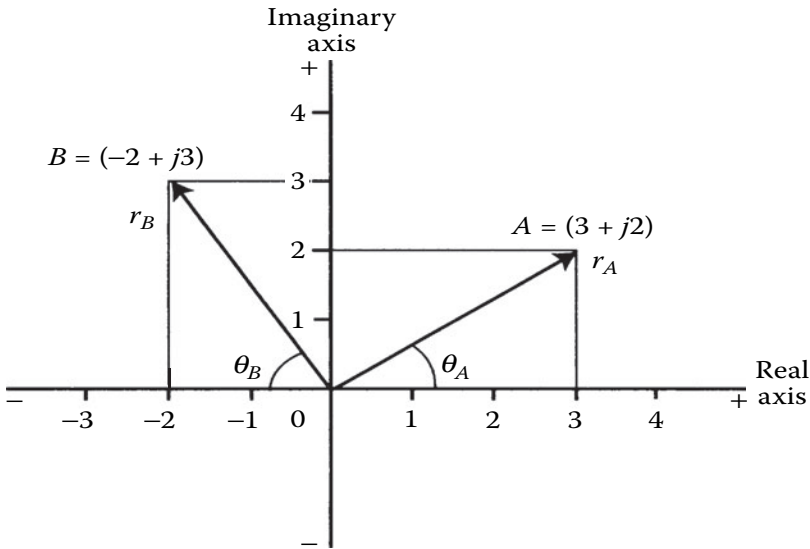


Figure 1.3 The *s* plane representing two complex numbers. (From Reference 3. Used with permission.)

written as  $\text{Im}(A)$ . It is a convention to precede the imaginary component by the letter *j* (or *i*). This form of writing the real and imaginary components is called the *Cartesian form* and symbolizes the complex (or *s*) plane, wherein both the real and imaginary components can be indicated graphically [3]. To illustrate this, consider the same complex number *A* when represented graphically, as shown in Figure 1.3. A second complex number *B* is also shown to illustrate the fact that the real and imaginary components can take on both positive and negative values. Figure 1.3 also shows an alternate form of representing complex numbers. When a complex number is represented by its magnitude and angle, for example,  $A = r_A \angle \theta_A$ , it is called the *polar representation*.

To see the relationship between the Cartesian and the polar forms, the following equations can be used:

$$r_A = \sqrt{a^2 + b^2} \tag{1.1}$$

$$\theta_A = \tan^{-1} \frac{b}{a} \tag{1.2}$$

Conceptually, a better perspective can be obtained by investigating the triangle shown in Figure 1.4, and considering the trigonometric relationships. From this figure, it can be seen that

$$a = \text{Re}(A) = r_A \cos(\theta_A) \quad (1.3)$$

$$b = \text{Im}(A) = r_A \sin(\theta_A) \quad (1.4)$$

The well-known *Euler's identity* is a convenient conversion of the polar and Cartesian forms into an exponential form, given by

$$\exp(j\theta) = \cos\theta + j\sin\theta \quad (1.5)$$

### 1.2.3 Phasors

The ac voltages and currents appearing in distribution systems can be represented by phasors, a concept useful in obtaining analytical solutions to one-phase and three-phase system design. A phasor is generally defined as a transform of sinusoidal functions from the time domain into the complex-number domain and given by the expression

$$\mathbf{V} = V \exp(j\theta) = P\{V\cos(\omega t + \theta)\} = V\angle\theta \quad (1.6)$$

where  $\mathbf{V}$  is the phasor,  $V$  is the magnitude of the phasor, and  $\theta$  is the angle of the phasor. The convention used here is to use boldface symbols to symbolize phasor quantities. Graphically, in the time domain, the phasor  $\mathbf{V}$  would be a simple sinusoidal wave shape, as shown in Figure 1.5. The concept of a phasor leading or lagging another phasor becomes very apparent from the figure.

Phasor diagrams are also an effective medium for understanding the relationships between phasors. Figure 1.6 shows a phasor diagram for the phasors represented in Figure 1.5. In this diagram, the convention of positive angles being read counterclockwise is used. The other alternative is certainly possible, as well. It is quite apparent that a purely capacitive load could result in the phasors shown in Figure 1.5 and Figure 1.6.

### 1.2.4 Per Unit System

In the per unit system, basic quantities such as voltage and current are represented as certain percentages of base quantities. When so expressed, these per unit quantities do not need units, thereby making numerical analysis in power systems somewhat easier to handle. Four quantities encompass all variables required to solve a power system problem. These quantities are:

- Voltage
- Current
- Power
- Impedance

Out of these, only two base quantities, corresponding to voltage ( $V_b$ ) and power ( $S_b$ ), are required to be defined. The other base quantities can be derived from these two. Consider the following. Let

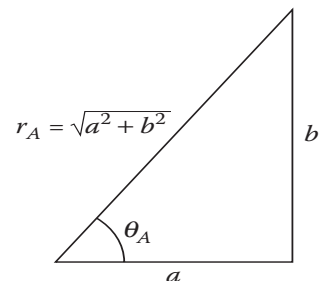
$V_b$  = Voltage base, kV

$S_b$  = Power base, MVA

$I_b$  = Current base, A

$Z_b$  = Impedance base, Q

Then,



**Figure 1.4** The relationship between Cartesian and polar forms. (From Reference 3. Used with permission.)

$$Z_b = \frac{V_b^2}{S_b} \Omega \quad (1.7)$$

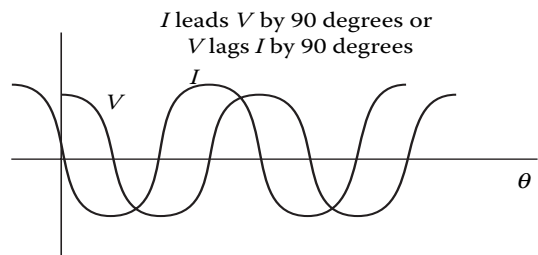
$$I_b = \frac{V_b 10^3}{Z_b} A \quad (1.8)$$

### 1.3 Elements of the AC Power System

The process of generating, distributing, and controlling the large amounts of power required for a municipality or geographic area is highly complex. However, each system, regardless of its complexity, is composed of the same basic elements with the same basic goal: deliver ac power where it is needed by customers. The primary elements of an ac power system can be divided into the following general areas of technology:

- Power generators
- Power transformers
- Capacitors
- Transmission circuits
- Control and switching systems, including voltage regulators, protection devices, and fault isolation devices

The path that electrical power takes to end users begins at a power plant, where electricity is generated by one of several means and is then stepped-up to a high voltage (500 kV is common) for transmission on high-tension lines. Step-down transformers reduce the voltage to levels appropriate for local distribution and eventual use by customers. Figure 1.7 shows how these elements interconnect to provide ac power to consumers.



**Figure 1.5** Waveforms representing leading and lagging phasors. (From Reference 3. Used with permission.)

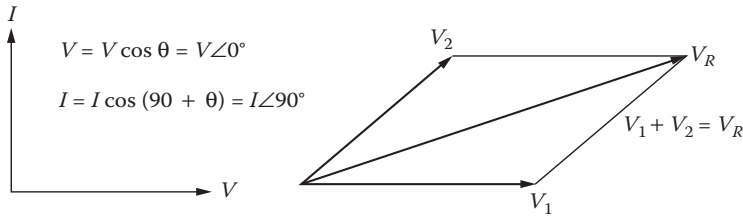
#### 1.3.1 Transmission Circuits

The heart of any utility power-distribution system is the cable used to tie distant parts of the network together. Conductors are rated by the American Wire Gauge (AWG) scale. The smallest is no. 36, and the largest is no. 0000. There are 40 sizes in between. Sizes larger than no. 0000 AWG are specified in *thousand circular mil* units, referred to as “MCM” units (M is the Roman numeral expression for 1000). The cross-sectional area of a conductor doubles with each increase of three AWG sizes. The diameter doubles with every six AWG sizes.

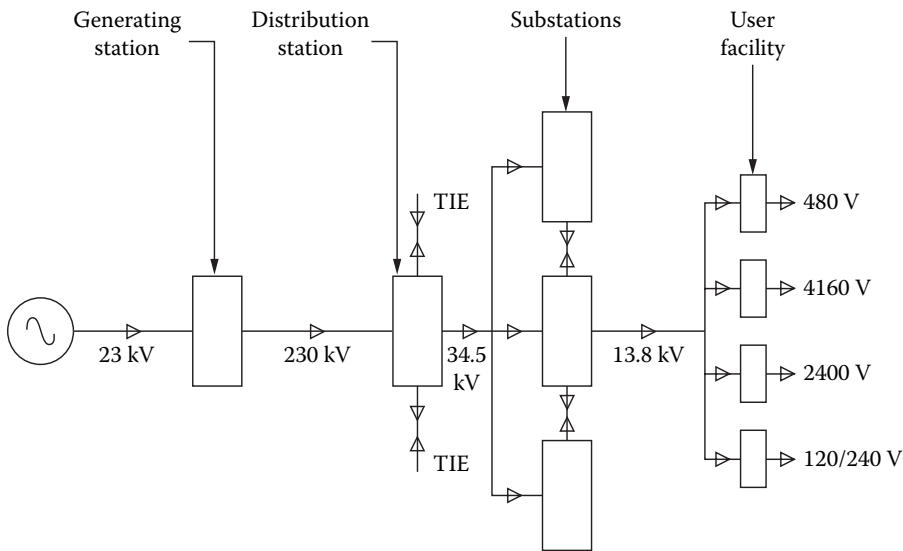
Most conductors used for power transmission are made of copper or aluminum. Copper is the most common. Stranded conductors are used where flexibility is required. Stranded cables usually are more durable than solid conductor cables of the same AWG size. For long distances, utilities typically use un-insulated aluminum conductors or aluminum conductor steel-reinforced cables. For shorter distances, insulated copper wire normally is used.

*Ampacity* is the measure of the ability of a conductor to carry electric current. Although all metals will conduct current to some extent, certain metals are more efficient than others. The three most common high-conductivity conductors are

- Silver, with a resistivity of 9.8  $\Omega$ /circular mil-ft
- Copper, with a resistivity of 10.4  $\Omega$ /circular mil-ft
- Aluminum, with a resistivity of 17.0  $\Omega$ /circular mil-ft



**Figure 1.6** Phasor diagram showing phasor representation and phasor operation. (From Reference 3. Used with permission.)



**Figure 1.7** A typical electrical power-generation and distribution system. Although this schematic diagram is linear, in practice power lines branch at each voltage reduction to establish the distribution network. (From [4]. Used with permission.)

The ampacity of a conductor is determined by the type of material used, the cross-sectional area, and the heat-dissipation effects of the operating environment. Conductors operating in free air will dissipate heat more readily than conductors placed in a larger cable or in a raceway with other conductors will. Table 1.1 lists the principal parameters of common wire sizes.

**1.3.1.1 Types of Conductors**

Wire and cable designed for use in a power-distribution system can be roughly divided into two categories:

- Overhead conductors
- Underground cables

Each will be examined in the following sections.

**1.3.1.2 Overhead Conductors**

Many different types of conductors are used on overhead distribution lines [3]. They vary in both size and number, depending on the voltage level and the type of circuit. Copper, aluminum, and steel are the most commonly used materials for overhead lines. Copper is used in three forms: hard drawn, medium-hard drawn, and soft drawn or *annealed*. Hard-drawn copper has the greatest strength and is used for circuits of relatively long spans (200 ft or more). However, its inflexibility makes it harder to

**Table 1.1** Characteristics of Copper Wire

Wire Size (AWG)	Diameter (mils)	Circular Mil Area	Ohms/1000 ft (20°C)	Current-Carrying Capacity at 700	
				C.M./A	Diameter (mm)
1	289.3	83,690	0.1239	119.6	7.348
2	257.6	66,370	0.1563	94.8	6.544
3	229.5	52,640	0.1970	75.2	5.827
4	204.3	41,740	0.2485	59.6	5.189
5	181.9	33,100	0.3133	47.3	4.621
6	162.0	26,250	0.3951	37.5	4.115
7	144.3	20,820	0.4902	29.7	3.665
8	128.5	16,510	0.6282	23.6	3.264
9	114.4	13,090	0.7921	18.7	2.906
10	101.9	10,380	0.9989	14.8	2.588
11	90.7	8,234	1.260	11.8	2.305
12	80.8	6,530	1.588	9.33	2.053
13	72.0	5,178	2.003	7.40	1.828
14	64.1	4,107	2.525	5.87	1.628
15	57.1	3,257	3.184	4.65	1.450
16	50.8	2,583	4.016	3.69	1.291
17	45.3	2,048	5.064	2.93	1.150
18	40.3	1,624	6.385	2.32	1.024
19	35.9	1,288	8.051	1.84	0.912
20	32.0	1,022	10.15	1.46	0.812
21	28.5	810	12.80	1.16	0.723
22	25.3	642	16.14	0.918	0.644

work with. The soft-drawn variety is the weakest of the copper conductors. Its use is limited to short spans. The medium-hard-drawn copper conductor has found widespread use in medium-range distribution circuits.

Steel wire is only about one tenth as good a conductor as copper and, hence, is rarely used alone. However, it offers an economic advantage over the other types of conductors. Also, because steel wire is much stronger than copper, it permits longer spans and requires fewer supports.

Aluminum is only 60 to 80% as good a conductor as copper and only half as strong as copper. However, its property of lighter weight, as compared to copper and steel, and its relative advantage in transmitting ac power because of reduced *skin effect* makes it suitable for overhead lines. Usually, the aluminum wires are stranded on a core of steel wire to form what is termed an *aluminum conductor steel-reinforced* (ACSR) conductor. The more strands in the ACSR conductor, the greater flexibility it will have. Hence, the larger conductors used today are all stranded and twisted in layers concentrically around a central steel wire.

Table 1.2 lists the characteristics of various conductors that are typically used on overhead distribution lines.

**Table 1.2** General Characteristics of Overhead Conductors (After [5].)

Conductor	Type	Resistance ( $\Omega$ / mi)	Diameter (in.)	Amperes
1,000,000	AA	0.1050	1.150	698
556,500	ACSR	0.1860	0.927	730
500,000	AA	0.2060	0.813	483
336,400	ACSR	0.3060	0.721	530
4/0	ACSR	0.5920	0.563	340
2/0	AA	0.7690	0.414	230
1/0	ACSR	1.1200	0.398	230
1/0	CU	0.6070	0.368	310
#2	AA	1.5400	0.292	156
#2	ACSR	1.6900	0.316	180
#4	ACSR	2.5500	0.257	140
#10	CU	5.9030	0.102	80
#12	CU	9.3750	0.081	75
#14	CU	14.8720	0.064	2

**1.3.1.3 Underground Cables**

Underground construction of distribution lines is designed mostly for urban areas and is dictated by economics, congestion, and density of population [3]. Although overhead lines have been ordinarily considered to be less expensive and easier to maintain, developments in underground cable and construction technology have narrowed the cost gap to the point where such systems are competitive in many urban and suburban residential installations.

The conductors used underground are different from overhead lines in that they are insulated for their entire length, and several of them may be combined under one protective sheath. The whole assembly is called an *electric cable*. These cables are either buried directly in the ground, or they may be installed in ducts buried in the ground. The conductors in cables are usually made of copper or aluminum and are usually stranded. They are made of soft-drawn copper because they do not have to support any appreciable weight. Cables can be either single conductor or multiple conductors enclosed in a single sheath for economy.

**1.3.1.4 Skin Effect**

The effective resistance offered by a conductor to high frequencies is considerably greater than the ohmic resistance measured with direct currents (dc). This is because of an action known as the *skin effect*, which causes the currents to be concentrated in certain parts of the conductor and leaves the remainder of the cross section to contribute little toward carrying the applied current.

When a conductor carries an alternating current, a magnetic field is produced that surrounds the wire. This field continually is expanding and contracting as the ac current wave increases from zero to its maximum positive value and back to zero, then through its negative half-cycle. The changing magnetic lines of force cutting the conductor induce a voltage in the conductor in a direction that tends to retard the normal flow of current in the wire. This effect is more pronounced at the center of the conductor. Thus, current within the conductor tends to flow more easily toward the surface of the wire. The higher the frequency, the greater the tendency for current to flow at the surface. The depth of current flow is a function of frequency and is determined from

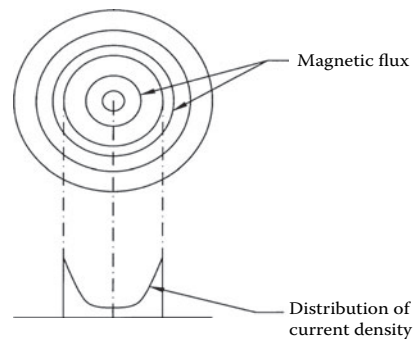
$$d = \frac{2.6}{\sqrt{\mu f}} \tag{1.9}$$

where

- $d$  = Depth of current in mils
- $\mu$  = Permeability (copper = 1, steel = 300)
- $f$  = Frequency of signal in MHz

It can be calculated that at a frequency of 100 kHz, current flow penetrates a conductor by 8 mils. At 1 MHz, the skin effect causes current to travel in only the top 2.6 mils in copper, and even less in almost all other conductors. Therefore, the series impedance of conductors at high frequencies is significantly higher than at low frequencies. Figure 1.8 shows the distribution of current in a radial conductor.

When a circuit is operating at high frequencies, the skin effect causes the current to be redistributed over the conductor cross section in such a way as to make most of the current flow where it is encircled by the smallest number of flux lines. This general principle controls the distribution of current regardless of the shape of the conductor involved. With a flat-strip conductor, the current flows primarily along the edges, where it is surrounded by the smallest amount of flux.



**Figure 1.8** The skin effect on a conductor.



It is evident from Equation 1.9 that the skin effect is minimal at power-line frequencies for copper conductors. For steel conductors at high current, however, skin effect considerations are often important.

### 1.3.2 Dielectrics and Insulators

Dielectrics are materials that are used primarily to isolate components electrically from each other or ground or to act as capacitive elements in devices, circuits, and systems [6]. The insulating properties of dielectrics are directly attributable to their large energy gap between the highest filled valence band and the conduction band. The number of electrons in the conduction band is extremely low because the energy gap of a dielectric (5 to 7 eV) is sufficiently large to maintain most of the electrons trapped in the lower band. As a consequence, a dielectric subjected to an electric field will allow only an extremely small conduction or *loss current*. This current will be caused by the following:

- The finite number of free electrons available
- Other free charge carriers (ions) typically associated with contamination by electrolytic impurities
- Dipole orientation losses arising with polar molecules under ac conditions

Often, the two latter effects will tend to obscure the minuscule contribution of the relatively few free electrons available. Unlike solids and liquids, vacuum and gases (in their nonionized state) approach the conditions of a perfect insulator — i.e., they exhibit virtually no detectable loss or leakage current.

Two fundamental parameters that characterize a dielectric material are its *conductivity*  $\sigma$  and the value of the *real permittivity* or *dielectric constant*  $\epsilon'$ . By definition,  $\sigma$  is equal to the ratio of the *leakage current density*  $J_l$  to the applied electric field  $E$

$$\sigma = \frac{J_l}{E} \quad (1.10)$$

Because  $J_l$  is in A cm<sup>-2</sup> and  $E$  is in V cm<sup>-1</sup>, the corresponding units of  $\sigma$  are in S cm<sup>-1</sup> or  $\Omega^{-1}$  cm<sup>-1</sup>.

Under ac conditions, *dielectric losses* arise mainly from the movement of free charge carriers (electrons and ions), space charge polarization, and dipole orientation. Ionic, space charge, and dipole losses are temperature and frequency dependent, a dependency that is reflected in the measured values of  $\sigma$  and  $\epsilon'$ . This necessitates the introduction of a complex permittivity  $\epsilon$  defined by  $\epsilon = \epsilon' - j\epsilon''$ , where  $\epsilon''$  is the imaginary value of the permittivity.

As the voltage is increased across a dielectric material, a point is ultimately reached beyond which the insulation will no longer be capable of sustaining any further rise in voltage and breakdown will ensue, causing a short circuit to develop between the electrodes. If the dielectric consists of a gas or liquid medium, the breakdown will be self-healing in the sense that the gas or liquid will support anew a reapplication of voltage. In a solid dielectric, however, the initial breakdown will result in a formation of a permanent conductive channel, which cannot support a reapplication of full voltage.

The breakdown strength of a dielectric under dc and impulse conditions tends to exceed that at ac fields, thereby suggesting the ac breakdown process is partially of a thermal nature. An additional factor, which may lower the ac breakdown strength, is that associated with the occurrence of partial discharges either in void inclusions or at the electrode edges. This leads to breakdown values much lower than the intrinsic value. In practice, breakdown values are generally of an extrinsic nature, and the intrinsic values are useful conceptually insofar as they provide an idea of an upper value that can be attained only under ideal conditions.

All insulating materials will undergo varying degrees of aging or deterioration under normal operating conditions. The rate of aging will be contingent upon the magnitude of the electrical, thermal, and mechanical stresses to which the material is subjected. It will also be influenced by the composition and molecular structure of the material itself, as well as the chemical, physical, and radiation environment under which the material must operate. The useful life of an insulating system will, thus, be determined by a given set and subset of aging variables. For example, the subset of variables in the voltage stress

variable are the average and maximum values of the applied voltage, its frequency, and the recurrence rate of superposed impulse or transient voltage surges. For the thermal stress, the upper and lower ambient temperatures, the temperature gradient in the insulation, and the maximum permissible operating temperature constitute the subvariable set. In addition, the character of the mechanical stress will differ, depending upon whether torsion, compression, or tension and bending are involved.

Furthermore, the aging rate will be differently affected if all stresses (electrical, thermal, and mechanical) act simultaneously, separately, or in some predetermined sequence. The influence exerted on the aging rate by the environment will depend on whether the insulation system will be subjected to corrosive chemicals, petroleum fluids, water or high humidity, air or oxygen, ultraviolet radiation from the sun, and nuclear radiation. Organic insulations, in particular, may experience chemical degradation in the presence of oxygen. For example, polyethylene under temperature cycle will undergo both physical and chemical changes. These effects will be particularly acute at high operating temperatures (90 to 130°C). At these temperatures, partial or complete melting of the polymer will occur, and the increased diffusion rate will permit the oxygen to migrate to a greater depth into the polymer. Ultimately, the antioxidant will be consumed, resulting in an embrittlement of the polymer and, in extreme cases, in the formation of macroscopic cracks. Subjection of the polymer to many repeated overload cycles will be accompanied by repeated melting and recrystallization of the polymer — a process that will inevitably cause the formation of cavities, which, when subjected to sufficiently high voltages, will undergo discharge, leading eventually to electrical breakdown.

The 60 Hz breakdown strength of a 1 cm gap of air at 25°C at atmospheric pressure is 31.7 kV cm<sup>-1</sup>. Although this is a relatively low value, air is a most useful insulating medium for large electrode separations, as is the case for overhead transmission lines. The only dielectric losses in the overhead lines are those resulting from corona discharges at the line conductor surfaces and leakage losses over the insulator surfaces. In addition, the highly reduced capacitance between the conductors of the lines ensures a small capacitance per unit length, thus rendering overhead lines an efficient means for transmitting large amounts of power over long distances.

### 1.3.2.1 Insulating Liquids

Insulating liquids are rarely used by themselves. Rather, they are intended for use mainly as impregnants with cellulose or synthetic papers [6]. The 60 Hz breakdown strength of practical insulating liquids exceeds that of gases; for a 1-cm gap separation, it is of the order of about 100 kV cm<sup>-1</sup>. However, because the breakdown strength increases with decreasing gap length and the oils are normally evaluated using a gap separation of 0.254 cm, the breakdown strengths normally cited range from approximately 138 to 240 kV cm<sup>-1</sup> (Table 1.3). The breakdown values are more influenced by the moisture and particle contents of the fluids than by their molecular structure.

Mineral oils have been extensively used in high-voltage electrical apparatus. They constitute a category of hydrocarbon liquids that are obtained by refining crude petroleum. Their composition consists of paraffinic, naphthenic, and aromatic constituents and is dependent upon the source of the crude as well as the refining procedure followed. The inclusion of the aromatic constituents is desirable because of their gas absorption and oxidation characteristics. Mineral oils used for cable and transformer applications have low polar molecule contents and are characterized by dielectric constants extending from about 2.10 to 2.25, with dissipation factors generally between  $2 \times 10^{-5}$  and  $6 \times 10^{-5}$  at room temperature, depending upon their viscosity and molecular weight. Their dissipation factors increase appreciably at higher temperatures when the viscosities are reduced. Oils may deteriorate in service because of oxidation and moisture absorption.

Alkyl benzenes are used as impregnants in high-voltage cables, often as substitutes for the low-viscosity mineral oils in self-contained, oil-filled cables. The electrical properties of alkyl benzenes are comparable to those of mineral oils, and they exhibit good gas inhibition characteristics. Because of their detergent character, alkyl benzenes tend to be more susceptible to contamination than mineral oils.

Since the discontinued use of the nonflammable *polychlorinated biphenyls* (PCBs), a number of unsaturated synthetic liquids have been developed for use in high-voltage capacitors, where, because of

**Table 1.3** Electrical Properties of Common Insulating Liquids (After [6].)

Liquid	Viscosity cSt (37.8°C)	Dielectric Constant (at 60 Hz, 25°C)	Dissipation Factor (at 60 Hz, 100°C)	Breakdown Strength (kV cm <sup>-1</sup> )
Capacitor oil	21.00	2.20	0.00100	> 118
Pipe cable oil	170.00	2.15	0.00100	> 118
Self-contained cable oil	49.70	2.30	0.00100	> 118
Heavy cable oil	2365.00	2.23	0.00100	> 118
Transformer oil	9.75	2.25	0.00100	> 128
Alkyl benzene	6.00	2.10	0.00040	> 138
Polybutene pipe cable oil	110.00 (SUS)	2.14 (at 1 MHz)	0.00030	> 138
Polybutene capacitor oil	2200.00 (SUS at 100°C)	2.22 (at 1 MHz)	0.00050	> 138
Silicone fluid	50.00	2.70	0.00015	> 138
Castor oil	98.00 (100°C)	3.74	0.06000	> 138
C <sub>8</sub> F <sub>16</sub> O fluorocarbon	0.64	1.86	< 0.00050	> 138

high stresses, evolved gases can readily undergo partial discharge. Most of these new synthetic capacitor fluids are, thus, gas-absorbing, low-molecular-weight derivatives of benzene, with permittivities ranging from 2.66 to 5.25 at room temperature (compared to 3.5 for PCBs). None of these fluids have the non-flammable characteristics of the PCBs; however, they do have high boiling points.

Silicone liquids consist of polymeric chains of silicon atoms alternating with oxygen atoms and with methyl side groups. For electrical applications, polydimethylsiloxane (PDMS) fluids are used, primarily in transformers as substitutes for the PCBs because of their inherently high flash and flammability points, and reduced environmental concerns.

### 1.3.2.2 Insulating Solids

Solid insulating materials can be classified into two main categories: organic and inorganic [13]. There are a large number of solid inorganic insulants available, including the following:

- *Alumina*, produced by heating aluminum hydroxide or oxyhydroxide; it is widely used as a filler for ceramic insulators. Further heating yields the *corundum structure*, which in its sapphire form is used for dielectric substrates in microcircuit applications.
- *Porcelain*, a multiphase ceramic material that is obtained by heating aluminum silicates until a *mullite* phase is formed. Because mullite is porous, its surface must be glazed with a high-melting-point glass to render it smooth and impervious to contaminants for use in overhead line insulators.
- *Electrical-grade glasses*, which tend to be relatively lossy at high temperatures. At low temperatures, however, they are suitable for use in overhead line insulators and in transformer, capacitor, and circuit breaker bushings. At high temperatures, their main application lies with incandescent and fluorescent lamps as well as electronic tube envelopes.
- *Mica*, a layer-type dielectric (mica films are obtained by splitting mica blocks). The extended two-dimensionally layered strata of mica prevents the formation of conductive pathways across the substance, resulting in a high dielectric strength. It has excellent thermal stability and, because of its inorganic nature, is highly resistant to partial discharges. It is used in sheet, plate, and tape forms in rotating machines and transformer coils.

Solid organic dielectrics consist of large polymer molecules, which generally have molecular weights in excess of 600. Primarily (with the notable exception of paper, which consists of cellulose that is comprised of a series of glucose units), organic dielectric materials are synthetically derived. Some of the more common insulating materials of this type include:

- *Polyethylene* (PE), perhaps one of the most common solid dielectrics. PE is extensively used as a solid dielectric extruded insulator in power and communication cables. Linear PE is classified as a low- (0.910 to 0.925), medium- (0.926 to 0.940), or high- (0.941 to 0.965) density polymer. Most of the PE used on extruded cables is of the cross-linked polyethylene type.
- *Ethylene-propylene rubber* (EPR), an amorphous elastomer that is synthesized from ethylene and propylene. It is used as an extrudent on cables where its composition has a filler content that

usually exceeds 50% (comprising primarily clay, with smaller amounts of added silicate and carbon black). Dielectric losses are appreciably enhanced by the fillers, and, consequently, EPR is not suitable for extra-high-voltage applications. Its use is primarily confined to intermediate voltages (< 69 kV) and to applications where high cable flexibility (due to its inherent rubber properties) may be required.

- *Polypropylene*, which has a structure related to that of ethylene with one added methyl group. It is a thermoplastic material having properties similar to high-density PE, although because of its lower density, polypropylene has also a lower dielectric constant. Polypropylene has many electrical applications, both in bulk form as molded and extruded insulations, as well as in film form in taped capacitor, transformer, and cable insulations.
- *Epoxy resins*, which are characterized by low shrinkage and high mechanical strength. They can also be reinforced with glass fibers and mixed with mica flakes. Epoxy resins have many applications, including insulation of bars in the stators of rotating machines, solid-type transformers, and spacers for compressed-gas-insulated busbars and cables.

Impregnated-paper insulation is one of the earliest insulating systems employed in electrical power apparatus and cables. Although many current designs use solid- or compressed-gas insulating systems, the impregnated-paper approach still constitutes one of the most reliable insulating techniques available. Proper impregnation of the paper results in a cavity-free insulating system, thereby eliminating the occurrence of partial discharges that inevitably lead to deterioration and breakdown of the insulating system. The liquid impregnants employed are either mineral oils or synthetic fluids.

Low-density cellulose papers have slightly lower dielectric losses, but the dielectric breakdown strength is also reduced. The converse is true for impregnated systems utilizing high-density papers. If the paper is heated beyond 200°C, the chemical structure of the paper breaks down, even in the absence of external oxygen, because the latter is readily available from within the cellulose molecule. To prevent this process from occurring, cellulose papers are ordinarily not used at temperatures above 100°C.

### 1.3.3 Control and Switching Systems

Specialized hardware is necessary to interconnect the elements of a power-distribution system. Utility control and switching systems operate under demanding conditions, including high voltage and current levels, exposure to lightning discharges, and 24-hour-a-day use. For reliable performance, large margins of safety must be built into each element of the system. The primary control and switching elements are high-voltage switches and protection devices.

High-voltage switches are used to manage the distribution network. Most disconnect switches function to isolate failures or otherwise reconfigure the network. Air-type switches are typically larger versions of the common *knife switch* device. To prevent arcing, air switches are changed only when power is removed from the circuit. These types of switches can be motor driven or manually operated.

Oil-filled circuit breakers are used at substations to interrupt current when the line is hot. The contacts usually are immersed in oil to minimize arcing. Oil-filled circuit breakers are available for operation at 500 kV and higher. Magnetic air breakers are used primarily for low-voltage indoor applications.

Protection devices include fuses and lightning arresters. Depending upon the operating voltage, various types of fuses can be used. Arc suppression is an essential consideration in the design and operation of a high-voltage fuse. A method must be provided to extinguish the arc that develops when the fuse element begins to open. Lightning arresters are placed at numerous points in a power-distribution system. Connected between power-carrying conductors and ground, they are designed to operate rapidly and repeatedly if necessary. Arresters prevent flashover faults between power lines and surge-induced transformer and capacitor failures. The devices are designed to extinguish rapidly, after the lightning discharge has been dissipated, to prevent power follow-on damage to system components.

A *fault* in an electrical power system is the unintentional and undesirable creation of a conducting path (a *short circuit*) or a blockage of current (an *open circuit*) [7]. The short-circuit fault is typically the most common and is usually implied when most people use the term “fault.” The causes of faults include

lightning, wind damage, trees falling across lines, vehicles colliding with towers or poles, birds shorting out lines, aircraft colliding with lines, vandalism, small animals entering switchgear, and line breaks resulting from excessive ice loading. Power system faults can be categorized as one of four types:

- Single line-to-ground
- Line-to-line
- Double line-to-ground
- Balanced three-phase

The first three types constitute severe unbalanced operating conditions.

It is important to determine the values of system voltages and currents during fault conditions so that protective devices can be set to detect and minimize their harmful effects. The time constants of the associated transients are such that sinusoidal steady-state methods can typically be used.

High-voltage insulators permit all of the foregoing hardware to be reliably interconnected. Most insulators are made of porcelain. The mechanical and electrical demands placed on high-voltage insulators are stringent. When exposed to rain or snow, the devices must hold off high voltages. They also must support the weight of heavy conductors and other components.

#### 1.3.3.1 Fault Protection Devices

Fuses are designed to melt and disconnect the circuit within which they are placed should the current in the circuit increase above a specified thermal rating [3]. Fuses designed to be used in circuits operating above 600 V are classified as *fuse cutouts*. Oil-filled cutouts are mainly used in underground installations and contain the fusible elements in an oil-filled tank. Expulsion-type cutouts are the most common devices used on overhead primary feeders. In this class of device, the melting of the fusible element causes heating of a fiber fuse tube, which, in turn, produces deionizing gases to extinguish the arc. Expulsion-type cutouts are classified as:

- Open-fuse cutouts
- Enclosed-fuse cutouts
- Open-link-fuse cutouts

The *automatic recloser* is an overcurrent device that automatically trips and recloses a preset number of times to clear or isolate faults. The concept of reclosing is derived from the fact that most utility system faults are temporary in nature and can be cleared by de-energizing the circuit for a short period of time. Reclosers can be set for a number of operation sequences, depending on the action desired. These typically include instantaneous trip and reclose operation followed by a sequence of time-delayed trip operations prior to lockout of the recloser. The minimum pick-up for most reclosers is typically set to trip instantaneously at two times the nominal current rating.

An *automatic line recloser* is constructed of an interrupting chamber and the related contacts that operate in oil, a control mechanism to trigger tripping and reclosing, an operator integrator, and a lock-out mechanism. An operating rod is actuated by a solenoid plunger that opens and closes the contacts in oil. Both single-phase and three-phase units are available.

The *line sectionalizer* is yet another overcurrent device. It is installed in conjunction with backup circuit breakers or reclosers. The line sectionalizer maintains coordination with the backup interrupting device and is designed to open after a preset number of tripping operations of the backup element. Line sectionalizers are installed on poles or crossarms in overhead distribution systems. The standard continuous current rating for sectionalizers ranges from 10 to 600 A. Sectionalizers also are available for both single-phase and three-phase systems.

The function of a circuit breaker is to protect a circuit from the harmful effects of a fault, in addition to energizing and de-energizing the same circuit during normal operation. Breakers are generally installed on both the incoming subtransmission lines and the outgoing primary feeders of a utility substation. These devices are designed to operate as quickly as possible (less than 10 cycles of the power frequency) to limit the impact of a fault on the distribution and control system. At the same time, the arc

that forms between the opening contacts must be quenched rapidly. Several schemes are available to extinguish the arc, the most common being immersion of the contacts in oil. Some circuit breakers have no oil, but quench the arc by a blast of compressed air. These are referred to as *air circuit breakers*. Yet another type encloses the contacts in a vacuum or a gas, such as sulfur hexafluoride ( $\text{SF}_6$ ).

Air circuit breakers are typically used when fault currents are relatively small. These devices are characteristically simple, are low cost, and require little maintenance. The fault current flows through coils, creating a magnetic field that tends to force the arc into ceramic chutes that stretch the arc, often with the aid of compressed air. When the arc is extinguished through vacuum, the breaker is referred to as a *vacuum circuit breaker*. Because a vacuum cannot sustain an arc, it can be an effective medium for this application. However, owing to imperfections present in a practical vacuum device, a small arc of short duration can be produced. The construction of vacuum circuit breakers is simple, but the maintenance is usually more complex than with other devices.

### 1.3.3.2 Lightning Arrester

A lightning arrester is a device that protects electrical apparatus from voltage surges caused by lightning [3]. It provides a path over which the surge can pass to ground before it has the opportunity to pass through and damage equipment. A standard lightning arrester consists of an air gap in series with a resistive element. The resistive element is usually made of a material that allows a low-resistance path to the voltage surge, but presents a high-resistance path to the flow of line energy during normal operation. This material is known as the *valve element*. Silicon carbide is a common valve element material. The voltage surge causes a spark that jumps across the air gap and passes through the resistive element to ground.

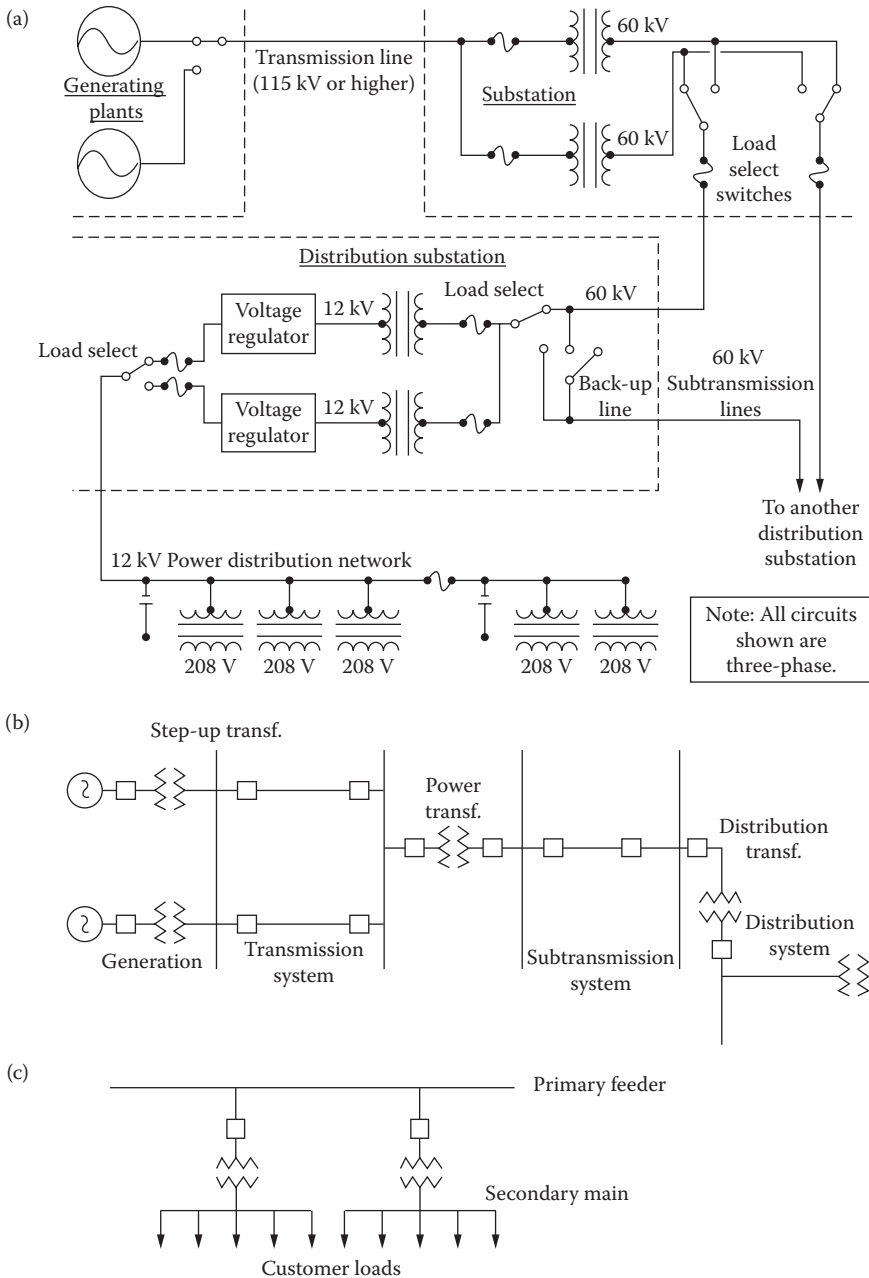
## 1.4 Utility AC Power System Architecture

The details of power distribution vary from one city or country to another, and from one utility company to another, but the basics are the same. Figure 1.9 shows a simplified distribution network. Power from a generating station or distribution grid comes into an area substation at 115 kV or higher. The substation consists of switching systems, step-down transformers, fuses, circuit breakers, reclosers, monitors, and control equipment. The substation delivers output voltages of approximately 60 kV to subtransmission circuits, which feed distribution substations. The substations convert the energy to approximately 12 kV and provide voltage regulation and switching provisions that permit patching around a problem. The 12 kV lines power pole- and surface-mounted transformers, which supply various voltages to individual loads. Typical end-user voltage configurations include:

- 120/208 V wye
- 277/480 V wye
- 120/240 V single phase
- 480 V delta

The circuits feeding individual customer loads are referred to as the *secondary system*, whereas the *primary system* is the network upstream from the secondary (Figure 1.9c). The secondary system originates at the distribution transformer and ends at the consumer loads. Each secondary main may supply groups of customers. In some instances, where service reliability is incorporated into the design, the secondary mains of several adjacent transformers may be connected through a fuse or a recloser. This is referred to as *secondary banking*. If an even higher service reliability factor is required, the secondary mains in an area can be connected in a mesh or a network, similar to the networking of the primary.

Fuses and circuit breakers are included at a number of points in the distribution system to minimize fault-caused interruptions of service. *Ground-fault interrupters* (GFIs) are also included at various points in the 12 kV system to open the circuit if excessive ground currents begin to flow on the monitored line. (GFIs are also known as *ground-fault current interrupters*, or GFCIs.) Reclosers may be included as part



**Figure 1.9** Simplified block diagram of a basic utility company power distribution system: (2) Overall network. The devices shown as fuses could be circuit breakers or reclosers. All circuits shown are three-phase. The capacitors perform power factor correction duty. (b) System terminology. (c) Distinction between the primary and secondary distribution systems. (b and c from [3]. Used with permission.)

of overcurrent protection of the 12 kV lines. They will open the circuit if excessive currents are detected and reclose after a preset length of time, as discussed in the previous section.

In some areas, the actions of circuit breakers, pole-mounted switches, and reclosers are controlled by two-way radio systems that allow status interrogation and switching of the remotely located devices from a control center. Some utilities use this method sparingly; others make extensive use of it.



**Table 1.4** Standard Utility System Voltages (kV) (After [15].)

Category	Nominal Rating	Maximum Rating
High voltage	34.5	36.5
	46.0	48.3
	69.0	72.5
	115.0	121.0
	138.0	145.0
	161.0	169.0
	230.0	242.0
Extra-high voltage (EHV)	345.0	362.0
	400.0 (principally in Europe)	
	500.0	550.0
	765.0	800.0
Ultra-high voltage (UHV)	1100.0	1200.0

Depending on the geographic location, varying levels of lightning protection are included as part of the ac power-system design. Most service drop transformers (12 kV to 208 V) have integral lightning arresters. In areas of severe lightning, a ground (or *shield*) wire is strung between the top insulators of each pole, diverting the lightning to the ground wire, and away from the hot leads.

Standard transmission voltages are established in the U.S. by the American National Standards Institute (ANSI). There is no clear delineation between distribution, subtransmission, and transmission voltage levels. Table 1.4 lists the standard voltages given in ANSI Standards C84 and C92.2.

### 1.4.1 Power Distribution

The distribution of power over a utility company network is a complex process involving a number of power-generating plants, transmission lines, and substations. The physical size of a metropolitan power-distribution and control system is immense. Substations use massive transformers, oil-filled circuit breakers, huge strings of insulators, and high-tension conductors in distributing power to customers. Power-distribution and -transmission networks interconnect generating plants into an *area grid*, to which *area loads* are attached. Most utility systems in the U.S. are interconnected to one extent or another. In this way, power-generating resources can be shared as needed. The potential for single-point failure also is reduced in a distributed system.

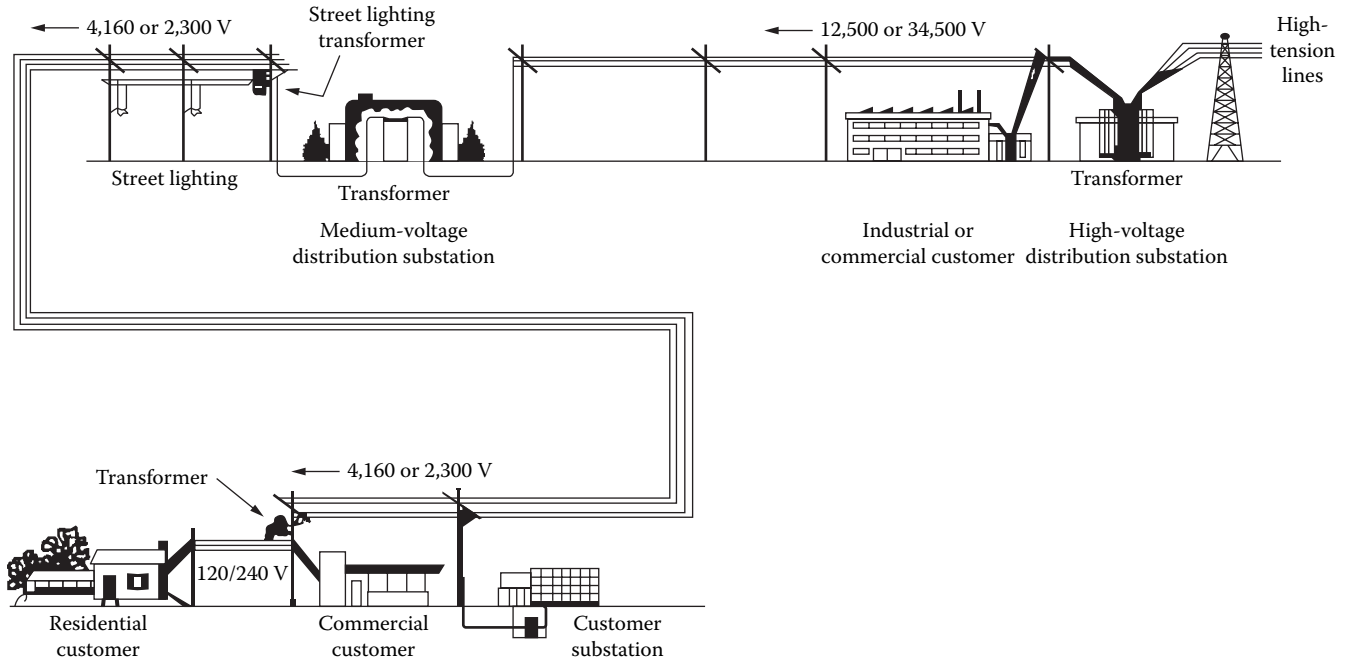
A typical power-distribution network is shown in [Figure 1.10](#). Power transmission lines operate at voltage levels from 2.3 kV for local distribution to 500 kV or more for distribution between cities or generating plants. Long-distance, direct current transmission lines also are used, with potentials of 500 kV and higher. Underground power lines are limited to short runs in urban areas. Increased installation costs and cable heat-management considerations limit the use of high-voltage underground lines. Wide variations in standard voltage levels can be found within any given system. Each link in the network is designed to transfer energy with the least  $I^2R$  loss, thereby increasing overall system efficiency. The following general classifications of power-distribution systems can be found in common use:

- *Radial system.* The simplest of all distribution networks, a single substation supplies power to all loads in the system. (See [Figure 1.11](#).)
- *Ring system.* Distribution lines encircle the service area, with power being delivered from one or more sources into substations near the service area. Power is then distributed from the substations through the radial transmission lines. (See [Figure 1.12](#).)
- *Network system.* A combination of the radial and ring distribution systems. Although such a system is more complex than either of the previous configurations, reliability is improved significantly. The network system, illustrated in [Figure 1.13](#), is one of the most common power-distribution configurations.

### 1.4.2 Distribution Substations

Distribution substations serve as the source for primary distribution feeders [3]. They receive bulk electric power at high voltages and reduce the voltage to distribution primary values. Also associated with a substation are provisions for protection from faults, for voltage regulation, and for data acquisition and monitoring. The equipment generally installed in a distribution substation includes:





**Figure 1.10** Simplified power-distribution architecture.

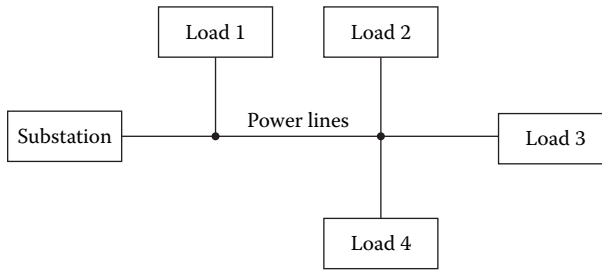


Figure 1.11 Radial power-transmission system.

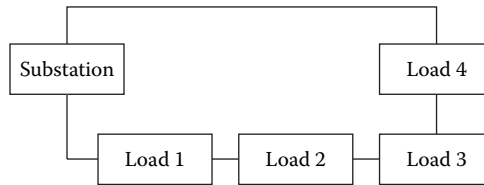


Figure 1.12 Ring power-transmission system.

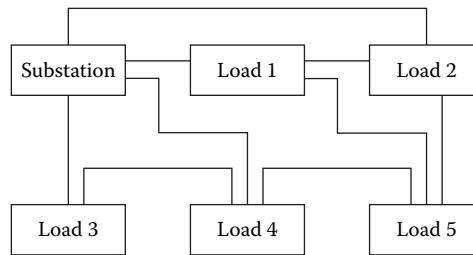


Figure 1.13 Network power-transmission system.

- Power transformers
- Oil or air circuit breakers
- Voltage regulators
- Protective relays
- Air break and disconnect switches
- Surge arresters
- Measuring instruments
- Storage batteries and capacitors (in some installations)

Some substations are entirely enclosed in buildings, whereas others are built entirely in the open with all equipment enclosed in one or more metal-clad units. The final design of the type of substation depends on economic factors; future load growth; and environmental, legal, and social issues.

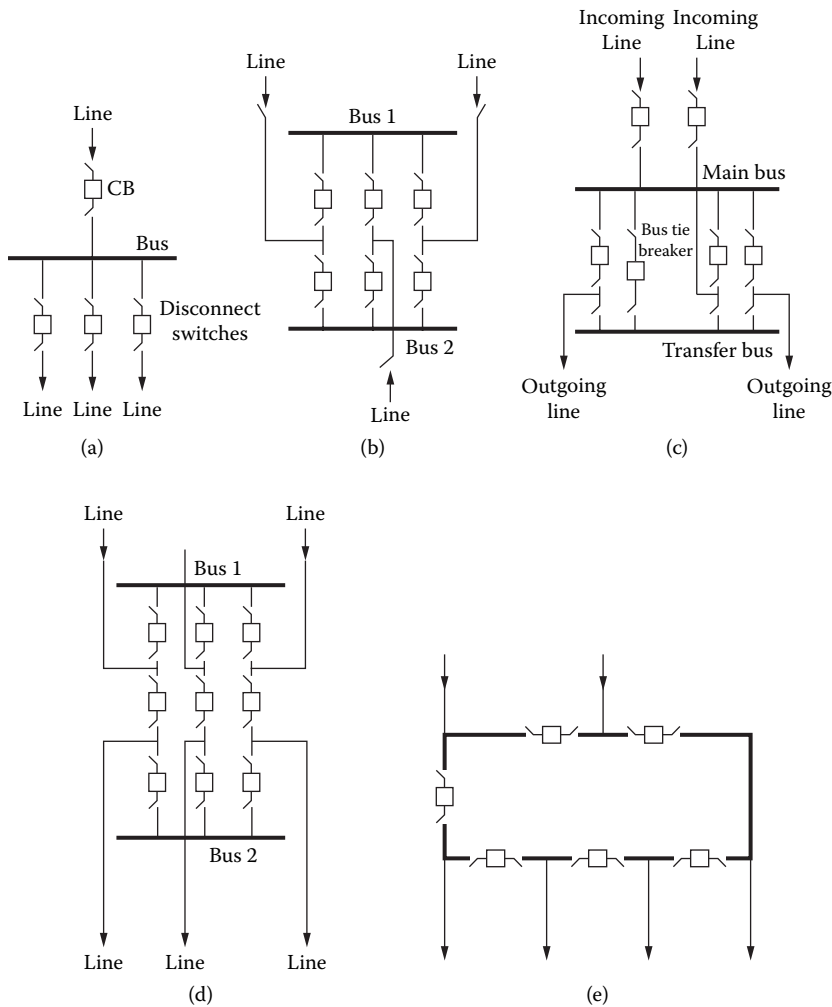
#### 1.4.2.1 Breaker Schemes

The circuit breaker scheme used at a substation provides for varying degrees of reliability and maintainability on both the input and output sides [3]. Each additional circuit breaker provides greater reliability and flexibility in maintaining the bus energized during a fault or during maintenance. However, the cost also increases with each circuit breaker. Hence, the selection of a particular substation scheme depends on safety, reliability, economy, and simplicity. The most commonly used circuit breaker schemes are [9]:

- The *single-bus*, shown in Figure 1.14a
- *Double-bus/double-breaker*, shown in Figure 1.14b

- *Main-and-transfer bus*, shown in Figure 1.14c
- *Breaker-and-a-half*, shown in Figure 1.14d
- *Ring bus*, shown in Figure 1.14e

Of these designs, the single-bus scheme costs the least; however, it possesses rather low reliability because the failure of the bus or any circuit breaker results in a total shutdown of the substation. The most expensive arrangement is the double-bus/double-breaker scheme. Each circuit is provided with two circuit breakers, and thus, any breaker can be taken out of service for maintenance without disruption of service at the substation. In addition, feeder circuits can be connected to either bus. The main-and-transfer bus requires an extra breaker for the bus tie between the main and the auxiliary buses. The breaker-and-a-half scheme provides the most flexible operation with high reliability. The relaying and automatic reclosing, however, are somewhat complex.



**Figure 1.14** Substation bus and breaker arrangements: (a) single-bus; (b) double-bus/double-breaker; (c) main-and-transfer bus; (d) breaker-and-a-half; (e) ring bus. (From [3]. Used with permission.)

### 1.4.3 Voltage Analysis

Distribution systems are designed to maintain service voltages within specified limits during normal and emergency conditions. Typical voltage limits are [3]:

- For service to residential customers, the voltage at the point of delivery shall not exceed 5% above or below the nominal voltage. This is equivalent to the band between 114 and 126 V for most utilities in the United States.
- For service to commercial or industrial customers, the voltage at the point of delivery shall not exceed 7.5% above or below the nominal voltage.
- The maximum allowable voltage imbalance for a three-phase service shall be 2.5%.

The goal of voltage analysis is to determine whether the voltages on different line sections remain within the specified limits under varying load conditions. Thus, voltage analysis facilitates the effective placement of capacitors, voltage regulators, and other voltage regulation devices on the distribution system. *Load flow analysis* is a computer-aided tool that is typically used in this planning task. Load flows determine feeder voltages under steady-state conditions and at different load conditions.

Voltage analysis begins with an accurate representation, or map, of the feeder circuits, starting at the substation. The map generally consists of details and electrical characteristics (such as kVA ratings, impedances, and other parameters) of the conductors and cables on the system, substation and distribution transformers, series and shunt capacitors, voltage regulators, and related devices.

Before the analysis can begin, feeder loading must be known. Several different methods can be used for this task. If the utility maintains a database on each customer connected to a distribution transformer, it can use the billing data to determine the kilowatt-hours supplied by each transformer for a given month. Methods can then be used to convert the kilowatt-hours to a noncoincident peak kilovoltampere demand for all distribution transformers connected on the feeder. If this information is not available, the kilovoltampere rating of the transformer and a representative power factor can be used as the load. With the metered demand at the substation, the transformer loads can be allocated, for each phase, such that the allocated loads plus losses will equal the metered substation demand.

Accurately representing the load types or models is an important issue in voltage analysis. Several load models are available, including:

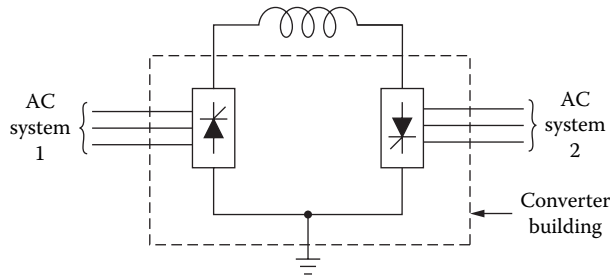
- Spot and distributed loads
- Wye and delta connected loads
- Constant power, constant current, constant impedance, or a combination of these methods

### 1.4.4 High-Voltage DC Transmission

High-voltage dc (HVDC) transmission offers several advantages over alternating current for long-distance power transmission and asynchronous interconnection between two ac systems, including the ability to precisely control the power flow without inadvertent *loop flows* that can occur in an interconnected ac system [9]. HVDC transmission can be classified into one of three broad categories:

- *Back-to-back* systems
- *Two-terminal*, or *point-to-point*, systems
- *Multiterminal* systems

In a back-to-back dc system, shown in [Figure 1.15](#), both the rectifier and the inverter are located in the same station, usually in the same building. The rectifier and inverter are usually integrated with a reactor, which is generally an air-core design. A back-to-back dc system is used to tie two *asynchronous* ac systems (systems that are not in synchronism). The two ac systems can be of different operating frequencies, for example, one 50 Hz and the other 60 Hz. Back-to-back dc links are also used to interconnect two ac systems that are of the same frequency but are not operating in synchronism. In North America, for example, Eastern and Western systems may not be synchronized, and Quebec and Texas may not be



**Figure 1.15** The back-to-back system of dc transmission. (From [9]. Used with permission.)

synchronized with their neighboring systems. A dc link offers a practical solution to interconnecting these nonsynchronous networks.

Two-terminal dc systems can be either *bipolar* or *monopolar*. The bipolar configuration, shown in Figure 1.16a, is the commonly used arrangement for systems with overhead lines. In this configuration, there are two conductors, one for each polarity (positive and negative) carrying nearly equal currents. Only the difference of these currents, which is usually small, flows through the ground return. A monopolar system has one conductor, either of positive or negative polarity, with current returning through either ground or another metallic return conductor. The monopolar ground return current configuration, shown in Figure 1.16b, has been used for undersea cable systems, where current returns through the sea. This configuration can also be used for short-term emergency operation for a two-terminal dc line system in the event of a pole outage. However, concerns about corrosion of underground metallic structures and interference with telephone and other utilities restrict the duration of such operation. The total ampere-hour operation per year is usually the restricting criterion. In a monopolar metallic return system, shown in Figure 1.16c, return current flows through a conductor, thus avoiding the problems associated with ground return current. This method is generally used as a contingency mode of operation for a normal bipolar transmission system in the event of a partial converter (one-pole equipment) outage. In the case of outage of a one-pole converter, the conductor of the affected pole will be used as the return current conductor. A metallic return transfer breaker is opened, diverting the return current from the ground path and into the pole conductor. This conductor is grounded at one end and insulated at the other end. This system can transmit half the power of the normal bipolar system capacity, and can be increased if overload capacity is available. However, the percentage of losses will be doubled compared to the normal bipolar operation.

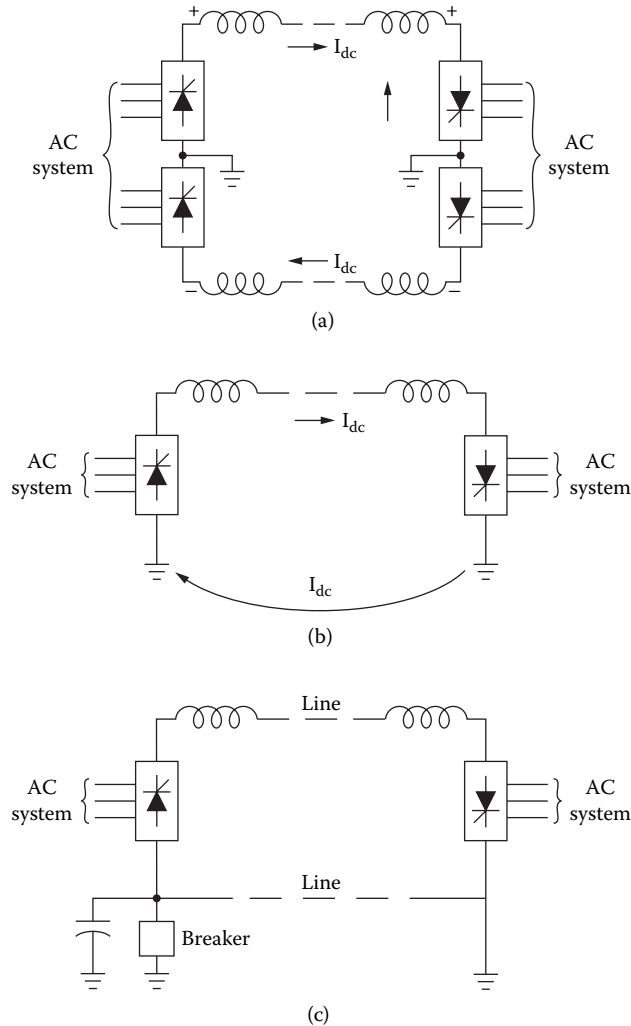
There are two basic configurations in which dc systems can be operated as *multiterminal systems*:

- Parallel configuration
- Series configuration

The parallel configuration can be either radial-connected (Figure 1.17a) or mesh-connected (Figure 1.17b). In a parallel-connected multiterminal dc system, all converters operate at the same nominal dc voltage, similar to ac system interconnections. In this mode of operation, one converter determines the operating voltage, and all other terminals operate in a current-controlling mode.

In a series-connected multiterminal dc system, shown in Figure 1.18, all converters operate at the same current. One converter sets the current that will be common to all converters in the system. Except for the converter that sets the current, the remaining converters operate in a voltage control mode (constant firing angle or constant extinction angle). The converters operate almost independently without the requirement for high-speed communication between them. The power output of a noncurrent-controlling converter is varied by changing its voltage. At all times, the sum of the voltages across the rectifier stations must be larger than the sum of voltages across the inverter stations. Disadvantages of a series-connected system include the following:

- Reduced efficiency because full line insulation is not used at all times.

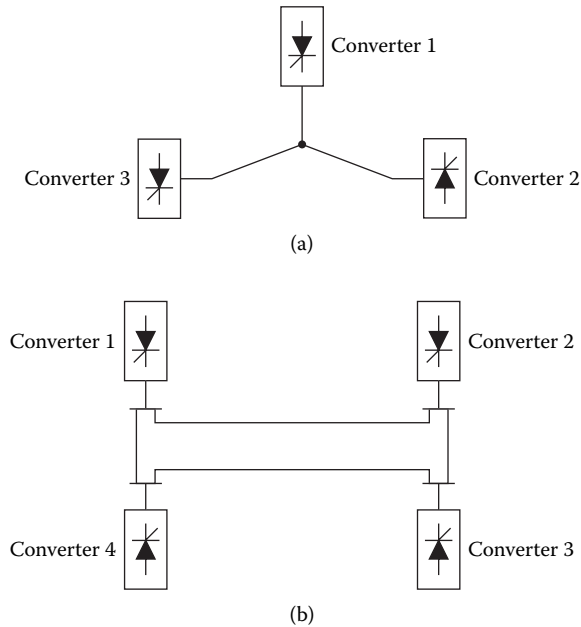


**Figure 1.16** Two-terminal dc transmission systems: (a) bipolar; (b) monopolar ground return; (c) monopolar metallic return. (From [9]. Used with permission.)

- Operation at higher firing angles leads to high converter losses and higher reactive power requirements from the ac system.

#### 1.4.4.1 AC vs. DC Transmission

In cases where HVDC is selected on technical considerations, it may be the only practical option, as in the case of an asynchronous interconnection [9]. However, for long-distance power transmission, where both ac and HVDC are practical, the final decision is dependent on the total costs of each alternative. The total cost of a transmission system includes the line costs (conductors, insulators, and towers) plus the right-of-way (R-o-W) costs. A dc line with two conductors can carry almost the same amount of power as a three-phase ac line with the same size of line conductors. However, dc towers with only two conductors are simpler and cheaper than three-phase ac towers. Hence, the per-mile costs of line and R-o-W will be lower for a dc line. Power losses in the dc line are also lower than for ac for the same power transmitted. However, the HVDC system requires converters at each end of the line; hence, the terminal costs for dc are higher than for ac. The variation of total costs for ac and dc as a function of line length is shown in Figure 1.19. As illustrated, there is a break-even distance beyond which the total costs of the dc option



**Figure 1.17** Multiterminal dc transmission systems: (a) parallel-connected radial; (b) parallel connected mesh-type. (From [9]. Used with permission.)

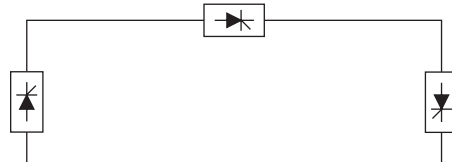
will be lower than the ac transmission option. This is in the range of 500 to 800 km for overhead lines, but much shorter for cables. The break-even point is between 20 and 50 km for submarine cables and twice as far for underground cables.

**1.4.4.2 DC Circuit Breakers**

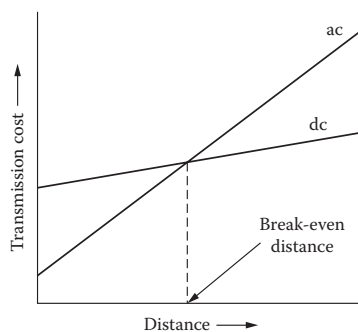
The process of interrupting the current in an ac system is aided by the fact that ac current goes through zero every half-cycle, or approximately every 8 ms in a 60 Hz system [9]. The absence of a natural *current zero* in dc makes it difficult to develop a dc circuit breaker. There are three principal problems that must be addressed:

- Forcing current zero in the interrupting element
- Controlling the overvoltages caused by large changes in current as a function of time ( $di/dt$ ) in a highly inductive circuit
- Dissipating large amounts of energy (tens of megajoules is not uncommon)

The second and third problems are solved by the application of zinc oxide varistors connected line to ground and across the breaking element. The first is the major problem, and several different solutions have been adopted by different manufacturers. Basically, current zero is achieved by inserting a *counter voltage* into the circuit.

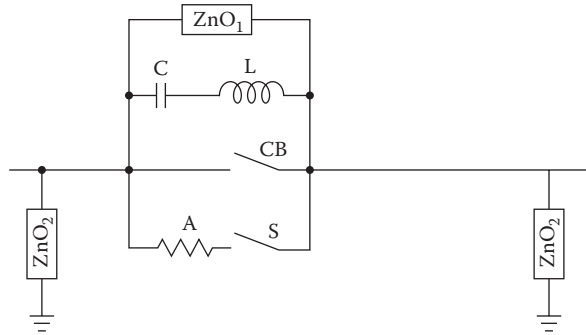


**Figure 1.18** Series connected multiterminal dc system. (From [9]. Used with permission.)



**Figure 1.19** Transmission system cost as a function of line length for ac and dc systems. (From [9]. Used with permission.)

In the circuit shown in Figure 1.20, opening CB (an air-blast circuit breaker) causes current to be commutated to the parallel LC tank. The commutating circuit will be oscillatory, which creates current zero in the circuit breaker. The opening of CB increases the voltage across the commutating circuit, which will be limited by the zinc oxide varistor  $ZnO_1$  by entering into conduction. The resistance  $R$  is the closing resistor in series with switch  $S$ .

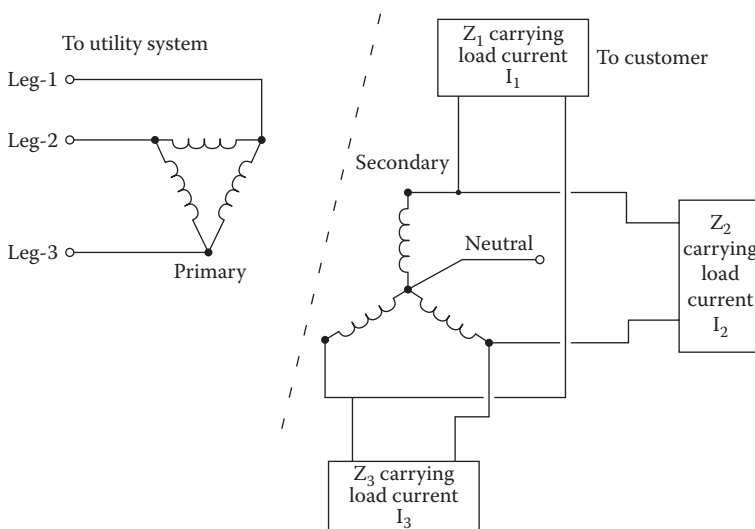


**Figure 1.20** Block diagram of a dc circuit breaker (one module). (From [9]. Used with permission.)

### 1.4.5 Utility Company Interfacing

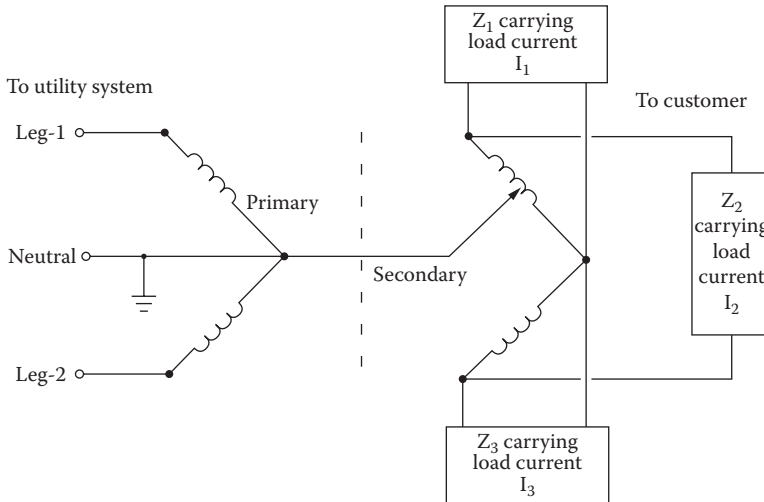
Most utility company-to-customer connections are the delta-wye type shown in Figure 1.21. This transformer arrangement usually is connected with the delta side facing the high voltage and the wye side facing the load. This configuration provides good isolation of the load from the utility and somewhat retards the transmission of transients from the primary to the secondary windings. The individual three-phase loads are denoted in the figure by  $Z_1$ ,  $Z_2$ , and  $Z_3$ . They carry load currents as shown. For a wye-connected system, it is important that the building neutral lead is connected to the midpoint of the transformer windings, as shown. The neutral line provides a path for the removal of harmonic currents that may be generated in the system as a result of rectification of the secondary voltages.

In some areas, an open-delta arrangement is used by the utility company to supply power to customers. The open-delta configuration is shown in Figure 1.22. Users often encounter problems when operating sensitive three-phase loads from such a connection because of poor voltage-regulation characteristics during varying load conditions. The open-delta configuration is also subject to high third-harmonic content and transient propagation. The three loads and their respective load currents are shown in the diagram.



**Figure 1.21** Delta-wye transformer configuration for utility company power distribution. This common type of service connection transformer provides good isolation of the load from the high-voltage distribution-system line.





**Figure 1.22** The open-delta (or V-V) utility company service connection transformer. This configuration is not recommended because of its poor voltage regulation under varying load, high third-harmonic content, and transient disturbance propagation characteristics.

Other primary power connection arrangements are possible, such as wye-to-wye or delta-to-delta. Like the delta-to-wye configuration, they are not susceptible to the problems that may be experienced with the open-delta (or V-V) service.

The open-delta system can develop a considerable imbalance among the individual phases in either voltage or phase or both. This can introduce a strong 120 Hz ripple frequency in three-phase power supplies, which are designed to filter out a 360 Hz ripple. The effects of this 120 Hz ripple can be increased noise in the supply and possible damage to protection devices across the power-supply chokes. Depending on the loading of an open-delta transformer, high third-harmonic energy can be transferred to the load, producing transients of up to 300% of the normal voltage. The result could be severely strained rectifiers, capacitors, and inductors in the power supply as well as additional output noise of the supply.

#### 1.4.5.1 Phase-to-Phase Balance

The phase-to-phase voltage balance of a utility company line is important at most types of facilities, not only because of the increased power-supply ripple that it can cause, but also because of the possible heating effects. Even simple three-phase devices such as motors should be operated from a power line that is well balanced, preferably within 1%. Studies have shown that a line imbalance of only 3.5% can produce a 25% increase in the heat generated by a three-phase motor. A 5% imbalance can cause a 50% increase in heat, which is potentially destructive. Similar heating also can occur in the windings of three-phase power transformers used in industrial equipment.

Phase-to-phase voltage balance can be measured accurately over a period of several days with a slow-speed chart recorder or electronic utility-line analyzer. The causes of imbalanced operation are generally large, single-phase power users on local distribution lines. Uneven currents through the utility company power-distribution system will result in uneven line-to-line voltages at the customer's service drop entrance.

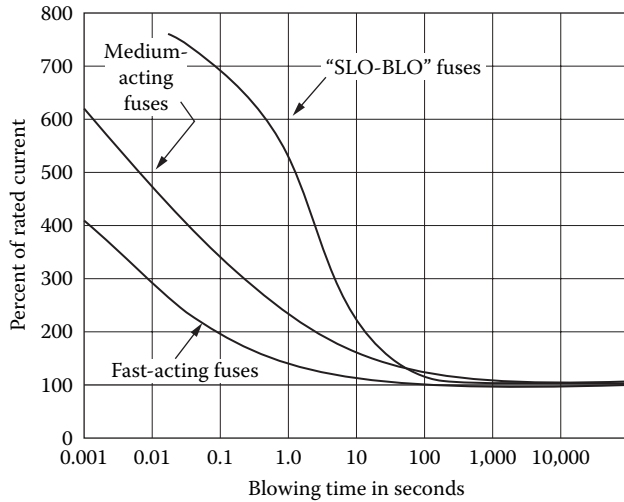
#### 1.4.6 Load Fault Protection

Fuses and circuit breakers are the two most common methods used in electronic equipment to prevent system damage in the event of a component failure. Although it is hardly new technology, there are still a lot of misconceptions about fuse and circuit-breaker ratings and operation.

**1.4.6.1 Fuses**

Fuses are rated according to the current they can pass safely. This may give the wrong idea — that excessive current will cause a fuse to blow. Rather, the cause is power dissipation in the form of heat. Put in more familiar terms, it is the  $I^2R$  loss across the fuse element that causes the linkage to melt. The current rating of a given device, however, is not the brick-wall-protection value that many service people think it is. Consider the graph shown in Figure 1.23, which illustrates the relationship of rated current across a fuse to the blowing time of the device.

Fuse characteristics can be divided into three general categories: fast-acting, medium-acting, and slow-blow. Circuit protection for each type of device is a function of both current and time. For example, a slow-blow fuse will allow approximately 6 times the rated current through a circuit for a full second before opening. Such delay characteristics have the benefit of offering protection against nuisance blowing because of high inrush currents during system startup. This feature, however, comes with the price of possible exposure to system damage in the event of a component failure.



**Figure 1.23** The relationship between the rated current of a fuse and its blowing time. Curves are given for three types of devices: fast-acting, medium-acting, and slow-blow.

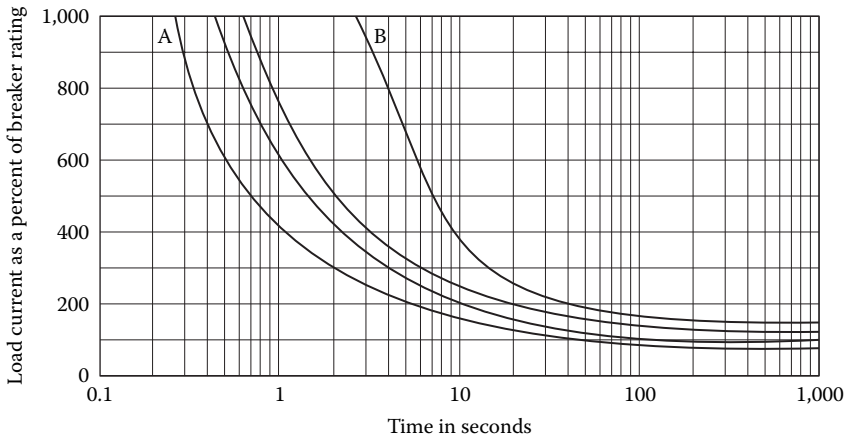
**1.4.6.2 Circuit Breakers**

Circuit breakers are subject to similar current let-through constraints. Figure 1.24 illustrates device load current as a percentage of breaker rating vs. time. The A and B curves refer to breaker load capacity product divisions. Note the variations possible in trip time for the two classifications. The minimum clearing time for the A group (the higher classification devices) is 1 s for a 400% overload. Similar to fuses, these delays are designed to prevent nuisance tripping caused by normally occurring current surges from (primarily) inductive loads. Most circuit breakers are designed to carry 100% of their rated load continuously without tripping. They normally are specified to trip at between 101 and 135% of rated load after a period of time determined by the manufacturer. In this example, the *must-trip point* at 135% is 1 hour.

Circuit breakers are available in both thermal and magnetic designs. Magnetic protectors offer the benefit of relative immunity to changes in ambient temperature. Typically, a magnetic breaker will operate over a temperature range of  $-40^{\circ}\text{C}$  to  $+85^{\circ}\text{C}$  without significant variation of the trip point. Time delays usually are provided for magnetic breakers to prevent nuisance tripping caused by startup currents from inductive loads. Trip-time delay ratings range from near instantaneous (under 100 ms) to slow (10 to 100 s).

**1.4.6.3 Semiconductor Fuses**

The need for a greater level of protection for semiconductor-based systems led to the development of semiconductor fuses. Figure 1.25 shows the clearing characteristics of a typical fuse of this type. The total clearing time of the device consists of two equal time segments: the *melting time* and the *arcing time*. The rate of current decrease during the arcing time must be low enough that high induced voltages, which could destroy some semiconductor components, are not generated.



(A) 5A to 50A models		(B) 0.5A to 4A models	
Overload Trip Times		Overload Trip Times	
100%	No trip	100%	No trip
135%	Trip in 1 hour	135%	Trip in 1 hour
200%	6–22 sec	200%	11–30 sec
600%	0.45–1.5 sec	600%	1.0–5.5 sec
1,000%	0.25–0.6 sec	1,000%	0.4–2.5 sec

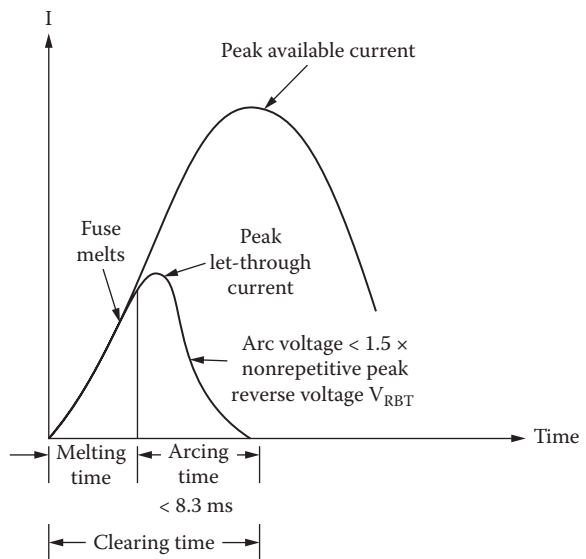
**Figure 1.24** The relationship between the rated current of a circuit breaker and its blowing time. Curves A and B represent different product current ranges, as shown.

**1.4.6.4 Application Considerations**

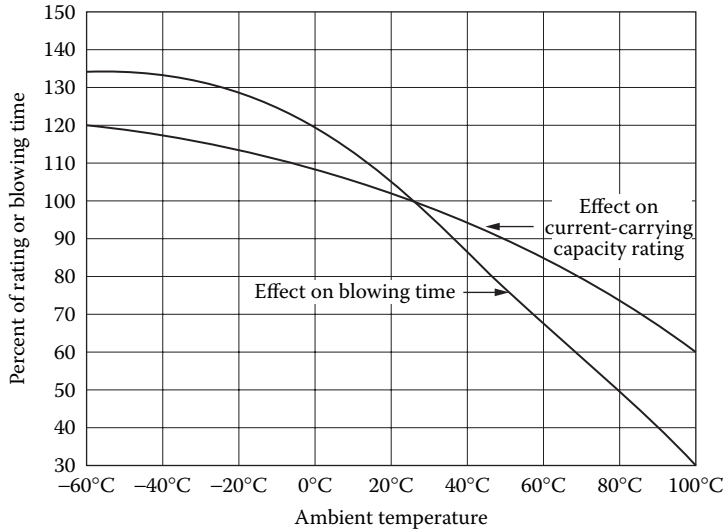
Although fuses and circuit breakers are a key link in preventing equipment damage during the occurrence of a system fault, they are not without some built-in disadvantages. Lead alloy fuses work well and are the most common protection device found, but because the current-interrupting mechanism is dependent on the melting of a metal link, their exact blow point is not constant. The interrupting current may vary, depending on the type and size of fuse clip or holder, conductor size, physical condition of the fuse element, extent of vibration present, and ambient temperature. Figure 1.26 illustrates the effects of ambient temperature on blowing time and current-carrying capacity.

**1.4.6.5 Transient Currents**

Trip delays for fuses and circuit breakers are necessary because of the high startup or inrush currents that occur when inductive loads or tungsten filament lamps are energized. The resistance of a tungsten lamp is high when it is hot, but low when it is cold. A current surge of as much as 15 times the rated steady-state value may occur when the lamp is energized (pulse duration approximately 4 ms).



**Figure 1.25** The current let-through characteristics of a semi-conductor fuse. Note that the clearing time of the device is less than 8.3 ms in this example.



**Figure 1.26** The effects of ambient temperature on fuse-blowing time and current-carrying capacity.

Transformer inrush currents can measure as high as 30 times the normal rated current for newer types of transformers that have grain-oriented high silicon steel cores. These transformer designs are attractive because of their favorable size and weight characteristics. Older transformers of more conventional design typically exhibit an inrush current approximately 18 times greater than the steady-state value. This transient current surge reaches its peak in the first half-cycle of applied ac power and decreases with each successive half-cycle. Such transients are relatively insensitive to the load placed on the secondary. The transient may, in fact, be smaller when the transformer is loaded than unloaded. A worst-case turn-on current surge will not occur every time the transformer is energized. Among the determining factors involved is the magnitude of the applied voltage at the instant the transformer is connected. Minimum transient energy occurs when the transformer is switched on at the zero-crossing point of the sine wave.

The magnitude of the turn-on current surge of an ac-to-dc power supply is determined mainly by the transformer transient and the capacitive load placed after the rectifier elements. Large filter capacitors commonly found in low-voltage, high-current supplies can place severe stress on the rectifiers and transformer. A fully discharged capacitor appears as a virtual short circuit when power is first applied. Some form of surge-limiting circuit often is provided for power supplies containing more than 10,000  $\mu\text{F}$  total capacitance.

The surge current of an ac motor is spread over tenths of a second, rather than milliseconds, and varies considerably with the load connected to the unit. [Table 1.5](#) lists typical motor surge currents for various types of devices. Note that the single-phase induction motor has the highest surge rating (7 times the running value for a period of 750 ms). Three-phase motors exhibit a relatively low-surge current during startup (350% for 167 ms).

#### 1.4.6.6 Delay-Trip Considerations

The occurrence of turn-on surges for inductive loads, ac-to-dc power supplies, and tungsten filament lamps dictates the installation of protective devices that exhibit delayed-trip characteristics that match the given load. The problem, however, is that high-surge currents of brief duration — not related to turn-on activities — can occur without tripping the circuit breaker or opening the fuse element. The result may be damage to other circuit devices, such as semiconductors. To provide full protection to an electronic system, the overload withstand characteristics of all components should match. This is not always an easy goal to accomplish.

**Table 1.5** Starting Surge Current Characteristics for Various Types of ac Motors Selected from a Random Test Group

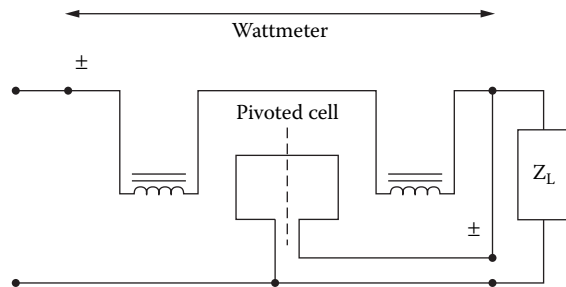
Motor Type	Start Current (peak amplitude, rms)	Duration of Start Surge (s)	Load-s (% $I \times t$ s)
Shaded pole	150%	2.000	0.30
Split phase no. 1	600%	0.116	0.70
Split phase no. 2	425%	0.500	2.00
Capacitor (loaded) no. 1	400%	0.600	2.40
Capacitor (no load)	300%	0.100	0.30
Capacitor (loaded) no. 2	420%	0.500	2.10
Induction	700%	0.750	5.00
Three phase	350%	0.167	0.60
Capacitor-start split-phase run	290%	0.083	0.24

For example, consider a simple SCR-controlled ac-to-dc power supply. The transformer will set the upper limit on surge current presented to the protective device and the SCR (assuming light capacitive loading). If that surge is 18 times the normal steady-state current for a period of 8 ms, then a protective device must be selected that will allow the surge to pass without tripping. An SCR must be selected for the circuit, therefore, that can withstand at least 18 times the normal rated current for 8 ms. If not, the SCR will become the weak link in the system, not the protective device.

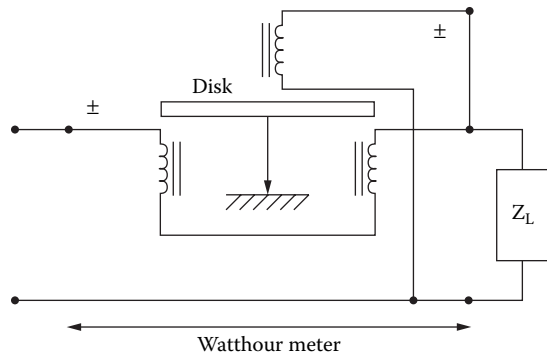
### 1.4.7 Measuring AC Power

Measuring the average power delivered to a load requires measurement of the rms values of voltage and current, as well as the power factor [10]. This is accomplished by an electro-dynamometer-type wattmeter, shown in Figure 1.27. The current in the high-resistance pivoted coil is proportional to the voltage across the load. The current to the load and the pivoted coil together through the energizing coil of the electromagnet establishes a proportional magnetic field across the cylinder of rotation of the pivoted coil. The torque on the pivoted coil is proportional to the product of the magnetic field strength and the current in the pivoted coil. If the current in the pivoted coil is negligible compared to that in the load, then the torque becomes essentially proportional to the product of the voltage across the load (equal to that across the pivoted coil) and the current in the load (essentially equal to that through the energizing coil of the electromagnet). The dynamics of the pivoted coil together with the restraining spring, at ac power frequencies, ensures that the angular displacement of the pivoted coil is proportional to the average of the torque or, equivalently, the average power.

One of the most common electrical instruments is the induction-type watt-hour meter, which measures the energy delivered to a load. In this design, the pivoted coil is replaced by a rotating conducting (usually aluminum) disk, as shown in Figure 1.28. An induced eddy current in the disk replaces the pivoted coil current in its interaction with the load-current-established magnetic field. After compensating for the less-than-ideal nature of the electrical elements making up this type of meter, the result is that the disk rotates at a



**Figure 1.27** A wattmeter connected to a load. (From [10]. Used with permission.)



**Figure 1.28** A watt-hour meter connected to a load. (From [10]. Used with permission.)

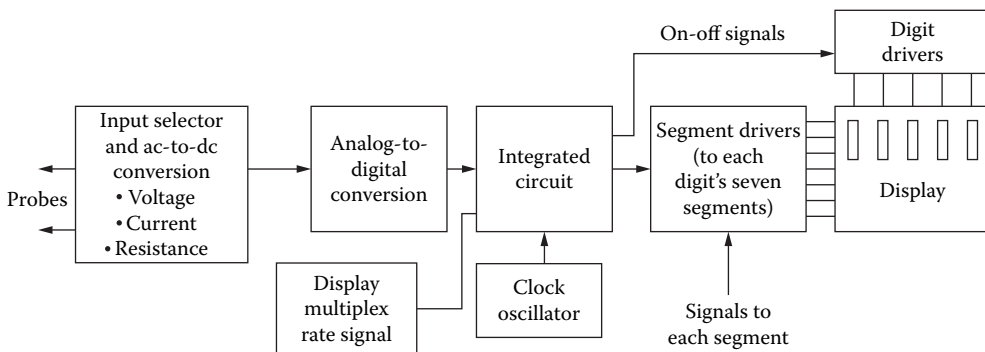
rate proportional to the average power of the load, and the rotational count is proportional to the energy delivered to the load.

At frequencies above the ac power frequency, and — in some instances — at the ac power frequencies, electronic instruments are used to measure power and energy. These systems are based on a variety of basic digital measurement techniques.

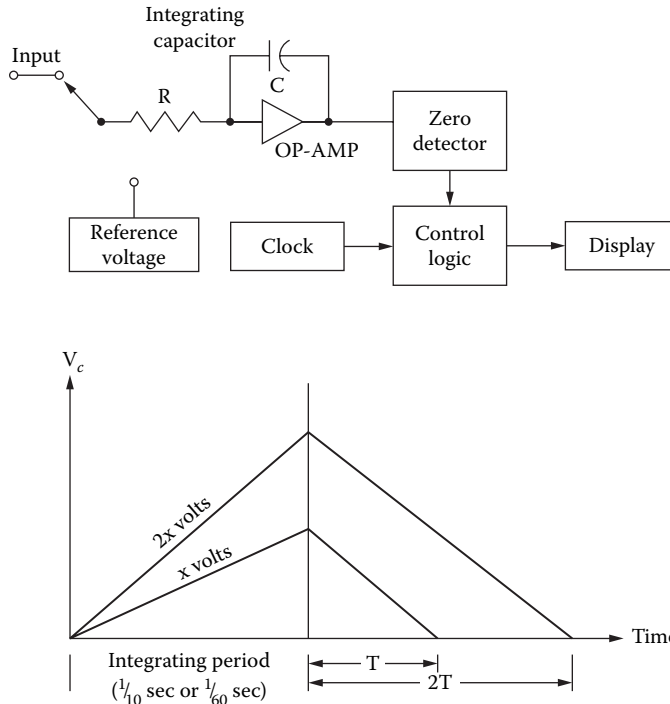
#### 1.4.7.1 Digital Measurement Techniques

Figure 1.29 shows a generalized block diagram of a digital voltmeter/ammeter. Conversion of an input voltage to a digital equivalent can be accomplished in one of several ways. The *dual-slope conversion* method (also known as *double-integration*) is one of the more popular techniques. Figure 1.30 illustrates the dual-slope conversion process.  $V_{in}$  represents the input voltage (the voltage to be measured).  $V_{REF}$  is a reference voltage with a polarity opposite that of the measured voltage, supplied by the digital conversion circuit. Capacitor C1 and operational amplifier U1 constitute an integrator. S1 is an electronic switch that is initially in the position shown. When the meter terminals are first connected to the circuit, the sample voltage is applied to the input of the integrator for a specified period of time, called the *integration period*. The integration period is usually related to the 60 Hz line frequency; integration periods of 1/60th of a second are common. S1 is an electronic switch that is initially in the position shown. When the meter terminals are first connected to the circuit, the sample voltage is applied to the input of the integrator for a specified period of time, called the *integration period*. The integration period is usually related to the 60 Hz line frequency; integration periods of 1/60th of a second and 1/10th of a second are common. The output signal of the integrator is a voltage determined by the resistor-capacitor (RC) time constant of R1 and C1. Because of the nature of the integrator, the maximum voltage (the voltage at the end of the integration period) is proportional to the voltage being measured. At the end of the integration period, switch S1 is moved to the other position ( $V_{REF}$ ) and a voltage of opposite polarity to the measured voltage is applied. The capacitor is then discharged to zero. As shown in the figure, the discharge interval is directly proportional to the maximum voltage, which, in turn, is proportional to the applied voltage at the input terminals.

At the same time that the integration interval ends and the discharge interval begins, a counter in the meter begins counting pulses generated by a clock circuit. When the voltage reaches zero, the counter stops. The number of pulses counted is, therefore, proportional to the discharge period. This count is converted to a digital number and displayed as the measured quantity. Although this method works well, it is somewhat slow, so many microcomputer-based meters use a variation called *multislope integration*.



**Figure 1.29** Block diagram of a basic digital voltage and current measuring device. It should be noted that advances in integrated circuit technology have reduced most of the individual elements shown to a single device.



**Figure 1.30** The analog-to-digital conversion process: (a) the basic circuitry involved; (b) graph of  $V_c$  vs. time. Because the slope of the discharge curve is identical regardless of the ultimate voltage reached by the integrator, the discharge period and, therefore, the number of counts recorded by the logic circuitry are proportional to the input voltage.

## 1.5 References

1. Bose, B. K., "Recent Advances in Power Electronics," *IEEE Transactions on Power Electronics*, IEEE, New York, Vol. 7, No. 1, p. 2, January 1992.
2. Bose, B. K., "Power Electronics — A Technology Review," *Proceedings of the IEEE*, IEEE, New York, NY, Vol. 80, No. 8, p. 1303, August 1992.
3. Chowdhury, B., "Power Distribution and Control," in *The Electronics Handbook*, J. C. Whitaker (Ed.), p. 1003, CRC Press, Boca Raton, FL, 1996.
4. Sankaran, C., "Transformers," in *The Electrical Engineering Handbook*, R. C. Dorf (Ed.), p. 33, CRC Press, Boca Raton, FL, 1993.
5. IEEE Working Group, "Radial Distribution Test Feeders," *IEEE Transactions on Power Systems*, IEEE, New York, Vol. 6, No. 3, p. 975, 1996.
6. Bartnikas, R., "Dielectrics and Insulators," in *The Electrical Engineering Handbook*, R. C. Dorf (Ed.), p. 1132, CRC Press, Boca Raton, FL, 1993.
7. Gross, C., "Fault Analysis in Power Systems," in *The Electrical Engineering Handbook*, R. C. Dorf (Ed.), p. 1252, CRC Press, Boca Raton, FL, 1993.
8. Chen, M.-S., "Transmission," in *The Electrical Engineering Handbook*, R. C. Dorf (Ed.), p. 1217, CRC Press, Boca Raton, FL, 1993.
9. Thallam, R. S., "High-Voltage Direct-Current Transmission," in *The Electrical Engineering Handbook*, R. C. Dorf (Ed.), p. 1227, CRC Press, Boca Raton, FL, 1993.
10. Balabanian, N., and T. A. Bickart, "Power and Energy," in *The Electrical Engineering Handbook*, R. C. Dorf (Ed.), p. 79, CRC Press, Boca Raton, FL, 1993.

## 1.6 Bibliography

---

- Davis, W., "Selecting Circuit Protective Devices," *Plant Electrical Systems*, PRIMEDIA Intertec, Overland Park, KS, March 1980.
- Fardo, S., and D. Patrick, *Electrical Power Systems Technology*, Prentice-Hall, Englewood Cliffs, NJ, 1985.
- Fink D., and D. Christiansen (Eds.), *Electronics Engineers' Handbook*, 3rd ed., McGraw-Hill, New York, 1989.
- Jay, F., *IEEE Standard Directory of Electrical and Electronics Terms*, 3rd ed., IEEE, New York, 1984.
- Jordan, E. C. (Ed.), *Reference Data for Engineers: Radio, Electronics, Computer, and Communications*, 7th ed., Howard W. Sams Company, Indianapolis, IN, 1985.
- Kramer, R. A., "Analytic and Operational Consideration of Electric System Reliability," *Proceedings of the Reliability and Maintainability Symposium*, IEEE, New York, 1991.
- Lawrie, R., *Electrical Systems for Computer Installations*, McGraw-Hill, New York, 1988.
- Mohan, N., and T. Undeland, *Power Electronics: Converters, Applications, and Design*, John Wiley, New York, 1989.
- Pearman, R., *Power Electronics*, Reston Publishing Company, Reston, VA, 1980.
- Stephens, D., "Surge Protection for Electric Motors," *Technical Briefs* newsletter, Burns & McDonnell, Kansas City, MO, February 1991.
- Technical staff, "The Susceptibility of the Open Delta Connection to Third Harmonic Disturbances," Harris Corporation, technical paper, Quincy, IL.



# 2

## Power-Generation Systems

---

### 2.1 Introduction

---

Any ac power system begins with a generating source. Electric generators are devices that convert energy from a mechanical form into an electrical form. This process, known as *electromechanical energy conversion*, involves magnetic fields that act as an intermediate medium. The input to the generating machine can be derived from a number of energy sources. For example, in the generation of large-scale electric power, coal can produce steam that drives the shaft of the machine. Typically, for such a thermal process, only about 1/3 of the raw energy (i.e., from coal) is converted into mechanical energy. The final step of the energy conversion is quite efficient, with efficiency close to 100%.

### 2.2 Fundamental Concepts

---

A simplified diagram of a three-phase generator is shown in [Figure 2.1](#). Note that poles  $A'$ ,  $B'$ , and  $C'$  represent the start of each of the phase windings, whereas poles  $A$ ,  $B$ , and  $C$  represent the ends of each of the windings. As with transformers, the windings of the generator can be connected in either of two ways:

- *Wye configuration*. A circuit arrangement in which the schematic diagram of the windings forms a Y.
- *Delta configuration*. A circuit arrangement in which the schematic diagram of the windings forms a delta.

[Figure 2.2](#) illustrates the connection arrangements.

The generator shown in [Figure 2.1](#) is a rotating-field type of device. A magnetic field is developed by an external dc voltage. Through electromagnetic induction, a current is induced into each of the stationary (*stator*) coils of the generator. Because each of the phase windings is separated by  $120^\circ$ , the output voltage of the generator also is offset for each phase by  $120^\circ$  ([Figure 2.3](#)). Three-phase power is used almost exclusively for power distribution because it is an efficient method of transporting electrical energy.

#### 2.2.1 Operating Principles

The operation of a generator is based on Faraday's law of electromagnetic induction [1]: If a coil (or winding) is linked to a varying magnetic field, then an electromotive force (emf or voltage) is induced across the coil. Thus, generators have two essential parts: one that creates a magnetic field, and the other where the emf energies are induced. The magnetic field is typically generated by electromagnets; thus, the field intensity can be adjusted for control purposes. These windings are referred to as *field windings* or *field circuits*. The coils where the emf energies are induced are called *armature windings* or *armature circuits*. One of these two components is stationary (the stator), and the other is a rotational part (the rotor) driven by an external torque. Conceptually, it is immaterial which of the two components is intended to rotate because, in either case, the armature circuits always experience a varying magnetic field. However, practical considerations lead to the common design that for ac generators, the field windings are mounted on the rotor and the armature windings on the stator.

Today, most electric power is produced by synchronous generators that rotate at a constant speed (the *synchronous speed*). This speed is dictated by the operating frequency of the system and the machine

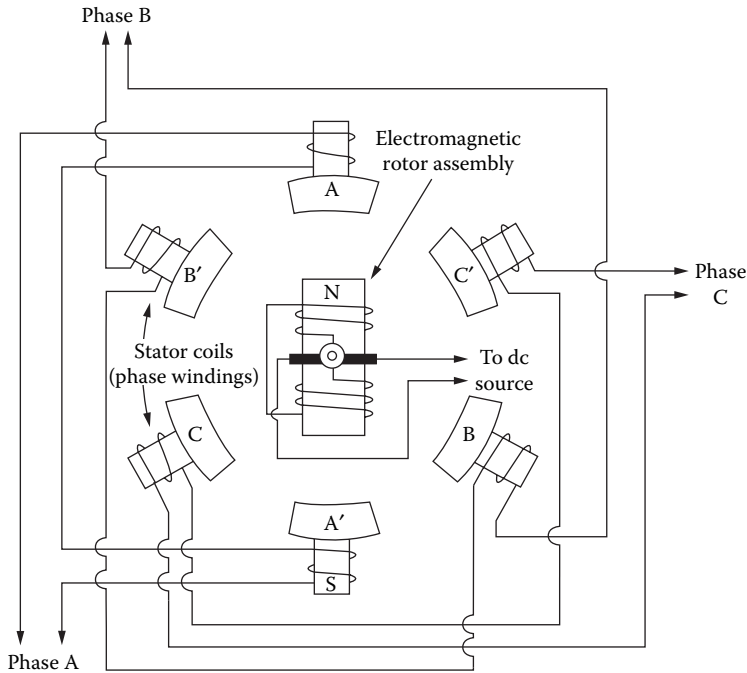


Figure 2.1 Simplified diagram of a three-phase ac generator.

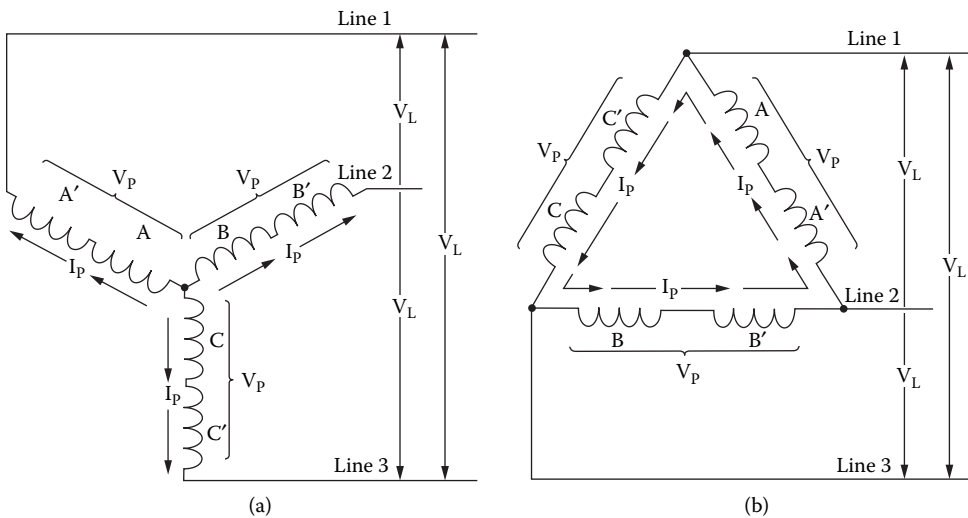


Figure 2.2 Generator circuit configurations: (a) wye; (b) delta.

structure. AC generators are also used that do not necessarily rotate at a fixed speed, such as those found in windmills (*induction generators*); these generators, however, account for only a small percentage of the power generated today.

For a better understanding of the principles of operation, see Figure 2.4, which shows a cross section of a basic ac machine. The rotor consists of a winding wrapped around a steel body. A dc current is made to flow in the rotor winding (or field winding), and this results in a magnetic field (rotor field). When the rotor is made to rotate at a constant speed, the three stationary windings  $aa'$ ,  $bb'$ , and  $cc'$  experience a periodically varying magnetic field. Thus, an emf is induced across these windings in accordance with Faraday's law. These forces are ac and periodic; each period corresponds to one revolution of the rotor. Thus, for 60 Hz electricity, the rotor must spin at 3600 revolutions per minute (rpm); this is the synchronous speed of the machine. Because the windings  $aa'$ ,  $bb'$ , and  $cc'$  are displaced equally in space from each other (by  $120^\circ$ ), their emf waveforms are displaced in time by one third of a period. In other words, the machine is capable of generating three-phase electricity.

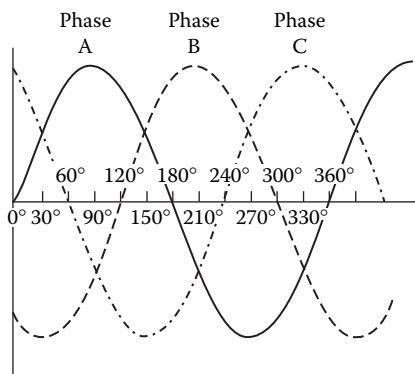


Figure 2.3 Output waveform of a three-phase generator.

When the stator windings are connected to an external (electrical) system to form a closed circuit, the steady-state currents in the windings are also periodic. This revolving field arises from the space displacements of the windings and the phase differences of their currents. The combined magnetic field has two poles and rotates at the same speed and direction as the rotor. It is important to observe that the armature circuits are in fact exposed to two rotating fields, one of which (the armature field) is caused by and tends to counter the effect of the other (the rotor field). The end result is that the induced emf in the armature can be reduced when compared with an unloaded machine (i.e., open-circuited stator windings). This phenomenon is referred to as *armature reaction*.

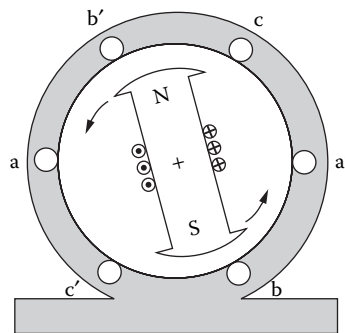
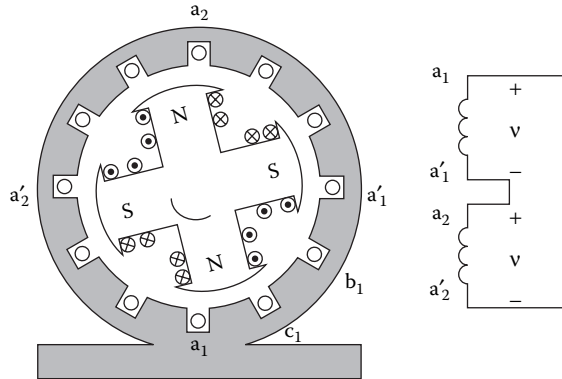


Figure 2.4 Cross section of a simple two-pole synchronous machine. (From [1]. Used with permission.)

It is possible to build a machine with  $p$  poles, where  $p = 4, 6, 8, \dots$  (even numbers). For example, the cross-sectional view of a four-pole machine is illustrated in Figure 2.5. For the specified direction of the (dc) current in the rotor windings, the rotor field has two pairs of north and south poles, arranged as shown. The emf induced in a stator winding completes one period for every pair of north and south poles sweeping by; thus, each revolution of the rotor corresponds to two periods of the stator emf. If the machine is to operate at 60 Hz, then the rotor needs to rotate at 1800 rpm. In general, a  $p$ -pole machine operating at 60 Hz has a rotor speed of  $3600/(p/2)$  rpm. That is, the lower the number of poles, the higher the rotor speed must be. In practice, the number of poles is dictated by the mechanical system (the *prime mover*) that drives the rotor. Steam turbines operate best at a high speed; thus, two- or four-pole machines are suitable. Machines driven by hydro turbines usually have more poles and operate at lower speeds.

The stator windings are typically arranged so that the resulting armature field has the same number of poles as the rotor field. In practice, there are many possible ways to arrange these windings. The essential idea, however, can be understood by studying the arrangement shown in Figure 2.5. Each phase consists of a pair of windings and thus occupies four slots on the stator structure. For example, those for phase  $a$  are labeled  $a_1a_1'$  and  $a_2a_2'$ . Geometry suggests that, at any time instant, equal electromotive forces are induced across the windings of the same phase. If the individual windings are connected in series, as shown in Figure 2.5, their energies add up to form the phase voltage.

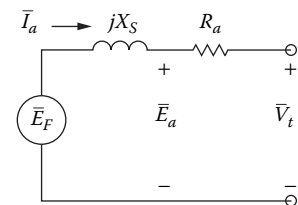


**Figure 2.5** A four-pole synchronous machine: (a) cross section of the machine; (b) schematic diagram for the phase *a* windings. (From [1]. Used with permission.)

In addition to the basic components of a synchronous generator (the rotor, stator, and their windings), auxiliary devices are used to help maintain the machine's operation within acceptable limits. These devices include the following:

- *Governor*. The function of the governor is to control the mechanical power input to the generator. The control is via a feedback loop where the speed of the rotor is constantly monitored. For instance, if this speed falls behind the synchronous speed, the input is insufficient and has to be increased. This is accomplished by opening a valve to increase the amount of steam for turbogenerators or the flow of water through the penstock for hydrogenerators. Governors are mechanical systems and, therefore, usually have some significant time lags (many seconds) compared to other electromagnetic parameters associated with the machine.
- *Damper windings (armortisseur windings)*. These windings are special conducting bars buried in notches on the rotor surface (the rotor resembles a squirrel-cage-rotor induction machine). The damper windings provide an additional stabilizing force for the machine during certain periods of operation. As long as the machine is in a steady state, the stator field rotates at the same speed as the rotor, and no currents are induced in the damper windings. However, when the speeds of the stator field and the rotor become different (because of a load disturbance), currents are induced in the damper windings in such a way as to keep the two speeds from separating.
- *Excitation control system*. Modern excitation systems are fast and efficient. An excitation control system is a feedback loop designed to maintain the voltage at the machine terminals at a set level. Figure 2.6 illustrates the mechanisms at work. Assume that a disturbance occurs in the system, and as a result, the machine terminal voltage  $V_t$  drops. The excitation system boosts the internal voltage  $E_f$ . This action can increase the voltage  $V_t$  and also tends to increase the reactive power output.

From a system viewpoint, the two controlling mechanisms of excitation and the governor rely on local information (the machine terminal voltage and rotor speed). In other words, they are *decentralized controls*. For large-scale systems, such designs do not always guarantee stable behavior because the effects of the interconnection system and other elements in the network are not taken into account. An analysis of the operation of centralized control systems is beyond the scope of this book; however, it is instructive to examine some of



**Figure 2.6** The per-phase equivalent circuit of a round-rotor synchronous machine.  $E_f$  is the internal voltage (phasor form) and  $V_t$  is the terminal voltage. (From [1]. Used with permission.)

the principles of decentralized control systems. Many of these principles apply in a modified form to centralized control techniques.

### 2.2.2 Control Techniques

Reliable electric power service implies that the loads are fed at a constant voltage and frequency at all times [1]. A stable power system is one in which the synchronous machines, if perturbed, will return to their original state if there is no net change in power, or stabilize at a new state without loss of synchronization. The machine rotor angle is used to quantify stability; that is, if the difference in the angle between machines increases or oscillates for an extended period of time, the system is considered unstable. The swing equation, given by

$$J\delta_m = J\omega_m = T_a \tag{2.1}$$

governs the motion of the machine rotor.  $J$  is moment of inertia,  $\delta_m$  is mechanical torque angle with respect to a rotating reference,  $\omega_m$  is shaft angular velocity, and  $T_a$  is the accelerating torque. Two factors that act as criteria for the stability of a generating unit are the angular swing of the machine during and following fault conditions, and the time it takes to clear the transient swing.

The mechanical torque of the prime mover — team or hydraulic — for a large generator depends on rotor speed. In an unregulated machine, the torque speed characteristic is linear over the rated range of speeds. The prime mover speed of a machine will drop in response to an increased load, and the valve position must be opened to increase the speed of the machine. In a regulated machine (governor controlled), the speed control mechanism controls the throttle valves to the steam turbine or the gate position for a water turbine.

Automatic voltage regulation can be used to adjust the field winding current, thus changing  $E_g$  as the load on the machine is varied (Figure 2.7). If the power output of a generator is to be increased while an automatic voltage regulator holds the bus voltage at a constant value, then the field winding current must be increased. The maximum voltage output of a machine is limited by the maximum voltage of the excitor supplying the field winding. Figure 2.8 illustrates control of a power-generating unit.

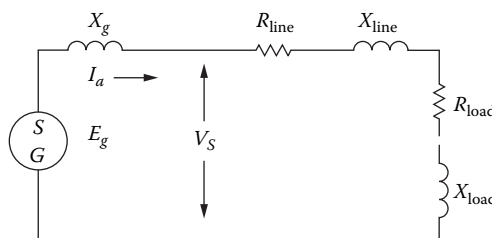


Figure 2.7 The basic power circuit of a generating system;  $V_s = E_g - I_a X_g$ . (From [1]. Used with permission.)

The performance of a transmission system can be improved by reactive compensation of a series or parallel type. Series compensation consists of banks of capacitors placed in series with each phase conductor of the line and is used to reduce the series impedance of the line, which is the principal cause of voltage drop. Shunt compensation consists of inductors placed from each line to neutral and is used to reduce the shunt susceptance of the line.

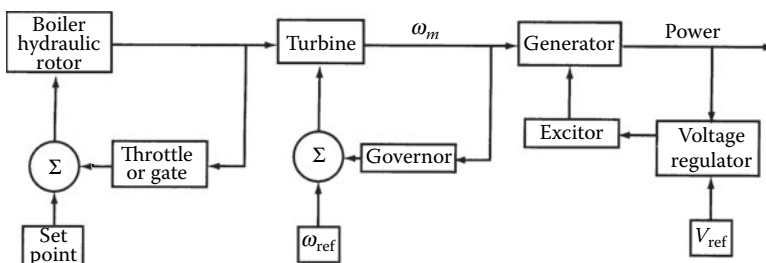


Figure 2.8 Block diagram of a generating control system (From [1]. Used with permission.)

## 2.3 Power-Generating Systems

Electrical power can be produced in many ways, including chemical reactions, heat, light, or mechanical energy. Most electrical power produced today is through hydroelectric plants and nuclear energy, and by burning coal, oil, or natural gas. Fossil fuel and nuclear-fission plants use steam turbines to deliver the mechanical energy required to rotate large three-phase generators, which produce massive quantities of electrical power. Generators used in such facilities usually are classified as high-speed units, operating at 3600 rpm to produce a 60 Hz output frequency. Hydroelectric systems use hydraulic turbines, mounted vertically to intercept the flow of water to produce electrical energy. Most hydroelectric facilities use low-speed generators, operating at from 120 to 900 rpm to produce 60 Hz. It follows that a larger number of poles are required for a low-speed generator.

Fossil fuels, used as a source of heat, are burned to produce steam in a boiler system. The steam then drives one or more generators. Coal and coke are used commonly to produce energy in this manner. Other fossil fuel sources include oil and natural gas.

A nuclear power plant is basically a fossil fuel facility with a nuclear power source to produce heat and then steam. Nuclear fission is a complex process that results in the division of the nucleus of an atom into two nuclei. This splitting of the atom is initiated by bombardment of the nucleus with neutrons, gamma rays, or other charged particles.

A hydroelectric system is the simplest of all power plants. Flowing water from a reservoir is channeled through a control gate that directs water to the blades of a hydraulic turbine. The turbine, in turn, drives one or more generators. Although simple in design and efficient in operation, hydroelectric systems are limited by the availability of a water reservoir.

Concern about the burning of fossil fuels and the safety of nuclear power has led to the development of alternative fuel sources for turbine-driven power plants. Power-generating systems now in operation include:

- Geothermal systems, which utilize the heat of a molten mass in the interior of the earth to produce steam, which drives a turbine generator. Such systems are efficient and simple, but their placement is limited to areas of geothermal activity.
- Wind systems, which use a number of small generators mounted on supports and attached to propeller-type blades to intercept prevailing winds. Naturally, generator output is determined by wind activity, limiting the use of these systems on any large scale.

Significant variations in load requirements must be satisfied at different times by a generating plant. Because of wide variations in load demands, much of the generating capability of a facility may be unused during low-demand periods. Two mathematical ratios commonly are used to measure utility service:

- *Load factor.* The average load for a given period divided by the peak load for that same period.
- *Capacity factor.* The average load for a given period divided by the output capacity of the power plant.

Under ideal conditions, both the load factor and the capacity factor are unity (100%). Commercial power systems use a number of three-phase generators connected in parallel, and synchronized in phase, to supply the load requirements.

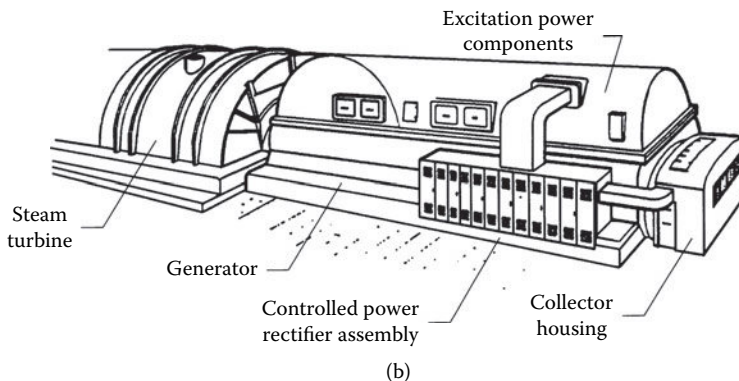
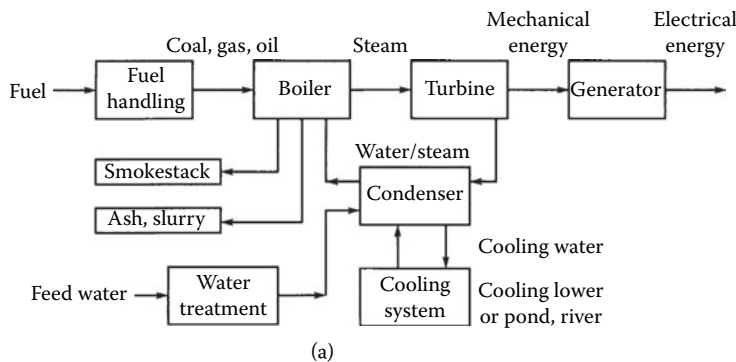
Table 2.1 lists general technical details for different types of common power plants.

### 2.3.1 Fossil Fuel Power Plants

The most frequently used fuels for large-scale power generation are oil, natural gas, and coal [3]. Figure 2.9 illustrates the principal elements of a fossil fuel power plant. Fuel handling includes transport by rail, on ships, or through pipelines. A power plant usually maintains several days of fuel reserve at any one

**Table 2.1** Power Plant Technical Data (After [2].)

Power Generation Type	Typical Size (MW)	Capitalized Plant Cost (\$/kW)	Construction Lead Time (Yr)	Heat Rate (BTU/kWh)	Fuel Type
Nuclear	1,200	2,400	10	10,400	Uranium
Pulverized coal/steam	500	1,400	6	9,900	Coal
Atmospheric fluidized bed	400	1,400	6	9,800	Coal
Gas turbine	100	350	2	11,200	Natural gas
Combined-cycle	300	600	4	7,800	Natural gas
Coal-gasification combined-cycle	300	1,500	6	9,500	Coal
Pumped storage hydro	300	1,200	6	–	–
Conventional hydro	300	1,700	6	–	–

**Figure 2.9** Primary components of a fossil fuel power plant: (a) system block diagram; (b) common configuration of turbine/generator system. (From [3]. Used with permission.)

time. Oil and gas are stored in large metal tanks, and coal is kept in open yards. The temperature of the coal layer must be monitored carefully to avoid self-ignition.

Oil is pumped and gas is fed to the burners of the boiler. Coal is pulverized in large mills, and the powder is mixed with air and transported by air pressure, through pipes, to the burners. The coal transport from the yard to the mills requires automated transporter belts, hoppers, and sometimes manually operated bulldozers.

Two types of boilers are used in modern power plants: the *subcritical* water-tube drum-type and the *supercritical* once-through type. The former operates around 2500 psi, which is below the water critical pressure of 3208.2 psi. The latter operates above that pressure, at approximately 3500 psi. The superheated steam temperature is about 1000°F (540°C) because of turbine temperature limitations.

A typical subcritical water-tube drum-type boiler has an inverted-U shape, as illustrated in Figure 2.10. On the bottom of the rising part is the furnace where the fuel is burned. The walls of the furnace are



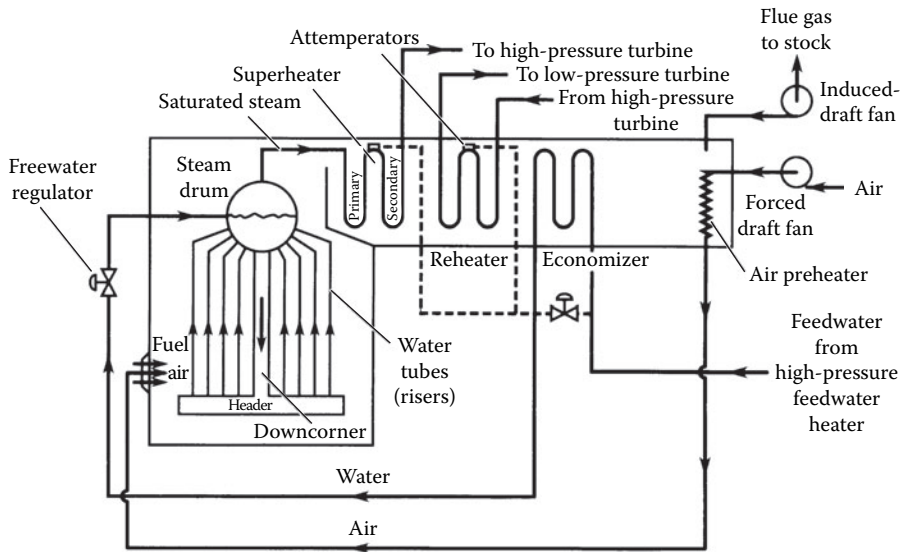


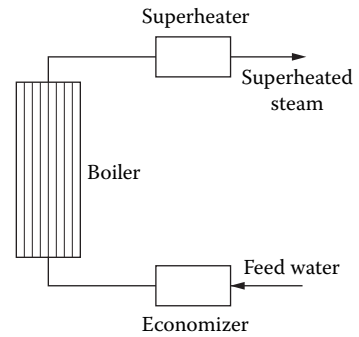
Figure 2.10 Flow diagram of a typical drum-type steam boiler. (From [4]. Used with permission.)

covered by water pipes. The drum and the superheater are at the top of the boiler. The falling part of the U houses the reheaters, economizer (water heater), and air preheater, which is supplied by the forced-draft fan. The induced-draft fan forces the flue gases out of the system and sends them up the stack, which is located behind the boiler. This steam generator has three major systems:

- **Fuel system.** Fuel is mixed with air and injected into the furnace through burners. The burners are equipped with nozzles, which are supplied by preheated air and carefully designed to assure the optimum air-fuel mix. The fuel mix is ignited by oil or gas torches. The furnace temperature is around 3000°F.
- **Air-flue gas system.** Ambient air is driven by the forced-draft fan through the air preheater, which is heated by the high-temperature (600°F) flue gases. The air is mixed with fuel in the burners and enters the furnace, where it supports the fuel burning. The hot combustion flue gas generates steam and flows through the boiler to heat the superheater, reheaters, economizer, and other related systems. Induced-draft fans, located between the boiler and the stack, increase the flow and send the 300°F flue gases to the atmosphere through the stack.
- **Water-steam system.** Large pumps drive the feedwater through the high-pressure heaters and the economizer, which further increases the water temperature (400 to 500°F). The former is heated by steam removed from the turbine; the latter is heated by the flue gases. The preheated water is fed to the steam drum. Insulated tubes called *downcomers* are located outside the furnace and lead the water to a header. The header distributes the hot water among the *risers*. These water tubes line the furnace walls. The water tubes are heated by the combustion gases through both convection and radiation. The steam generated in these tubes flows to the drum, where it is separated from the water. Circulation is maintained by the density difference between the water in the downcomer and the water tubes. Saturated steam, collected in the drum, flows through the superheater. The superheater increases the steam temperature to about 1000°F. Dry superheated steam drives the high-pressure turbine. The exhaust from the high-pressure turbine goes to the reheater, which again increases the steam temperature. The reheated steam drives the low-pressure turbine.



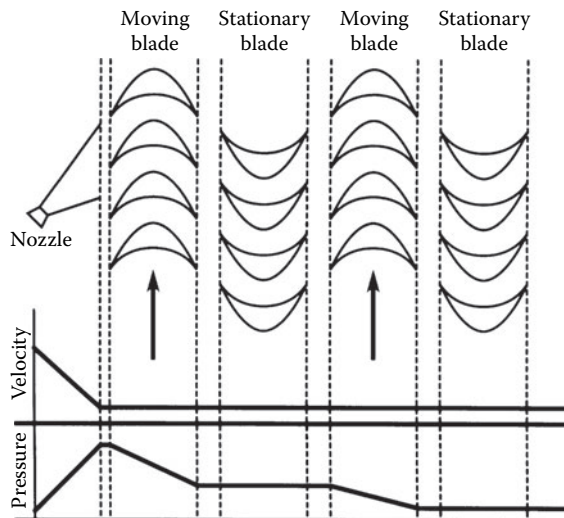
The typical supercritical once-through-type boiler concept is shown in Figure 2.11. The feedwater enters through the economizer to the boiler, which consists of riser tubes that line the furnace wall. All the water is converted to steam and fed directly to the superheater. The latter increases the steam temperature above the critical temperature of the water and drives the turbine. The construction of these steam generators is more expensive than the drum-type units but has a higher overall operating efficiency.



**Figure 2.11** Block diagram of a once-through-type steam generator. (From [3]. Used with permission.)

The turbine converts the heat energy of the steam into mechanical energy. Modern power plants typically use one high-pressure and one or two lower-pressure turbines. High-pressure steam enters the high-pressure turbine to flow through and drive the turbine. The exhaust is reheated in the boiler and returned to the lower-pressure units. Both the rotor and the stationary part of the turbine have blades. The length of the blades increases from the steam entrance to the exhaust. Figure 2.12 shows the blade arrangement of an impulse-type turbine. Steam enters through nozzles and flows through the first set of moving rotor blades. The following stationary blades change the direction of the flow and direct the steam into the next set of moving blades. The nozzles increase the steam speed and reduce pressure, as shown in the figure. The impact of the high-speed steam, generated by the change of direction and speed in the moving blades, drives the turbine.

In a fossil fuel plant, the generator converts mechanical energy from the turbines into electrical energy. The stator typically has a laminated and slotted silicon steel iron core. The stacked core is clamped and held together by insulated axial through bolts. The stator winding is placed in the slots and consists of a copper-strand configuration with woven glass insulation between the strands and mica flakes, mica mat, or mica paper groundwall insulation. To avoid insulation damage caused by vibration, the groundwall insulation is reinforced by asphalt, epoxy-impregnated fiberglass, or Dacron. Most frequently, the stator is hydrogen-cooled; however, small units may be air-cooled, and very large units may be water-cooled. The solid steel rotor has slots milled along the axis. The multiturn copper rotor winding is placed in the slots and cooled by hydrogen. Cooling is enhanced by subslots and axial cooling passages. The rotor winding is restrained by wedges inserted in the slots.



**Figure 2.12** Velocity and pressure variation in an impulse turbine. (From [3]. Used with permission.)

The rotor winding is supplied by dc current, either directly by a brushless excitation system or through collector rings. The nondrive-end bearing is insulated to avoid shaft current generated by stray magnetic fields. The hydrogen is cooled by a hydrogen-to-water heat exchanger mounted on the generator or installed in a closed-loop cooling system.

The condenser condenses turbine exhaust steam to water, which is pumped back to the steam generator through various water heaters. This condensation produces a vacuum, which is necessary to exhaust the steam from the turbine. The condenser usually is a shell-and-tube heat exchanger, where steam condenses on water-cooled tubes. Cold water is obtained from the cooling towers or other cooling systems. The condensed water is fed through a deaerator, which removes absorbed gases from the water. Next, the gas-free water is mixed with the feedwater and returned to the boiler. The gases absorbed in the water may cause corrosion and increase condenser pressure, adversely affecting efficiency. Older plants use a separate deaerator heater, whereas deaerators in modern plants are usually integrated in the condenser, where injected steam jets produce a pressure drop and remove absorbed gases.

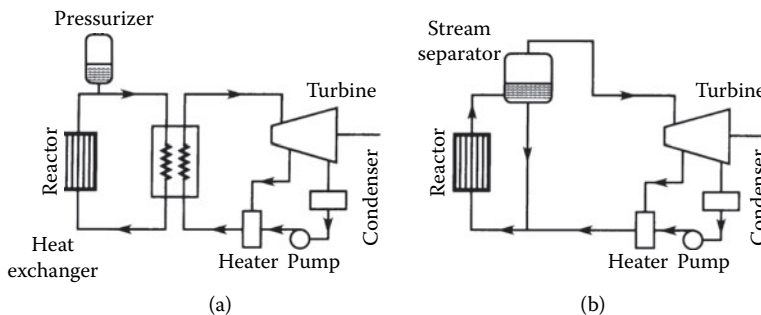
### 2.3.2 Nuclear Power Plants

There are approximately 500 nuclear power plants operating around the world [3]. Close to 300 operate *pressurized water reactors* (PWRs), more than 100 are built with *boiling-water reactors* (BWRs), about 50 use gas-cooled reactors, and the rest are *heavy-water reactors*. In addition, a few *fast breeder reactors* are in operation. These reactors are built for better utilization of uranium fuel. The modern nuclear plant size varies from 100 to 1200 MW.

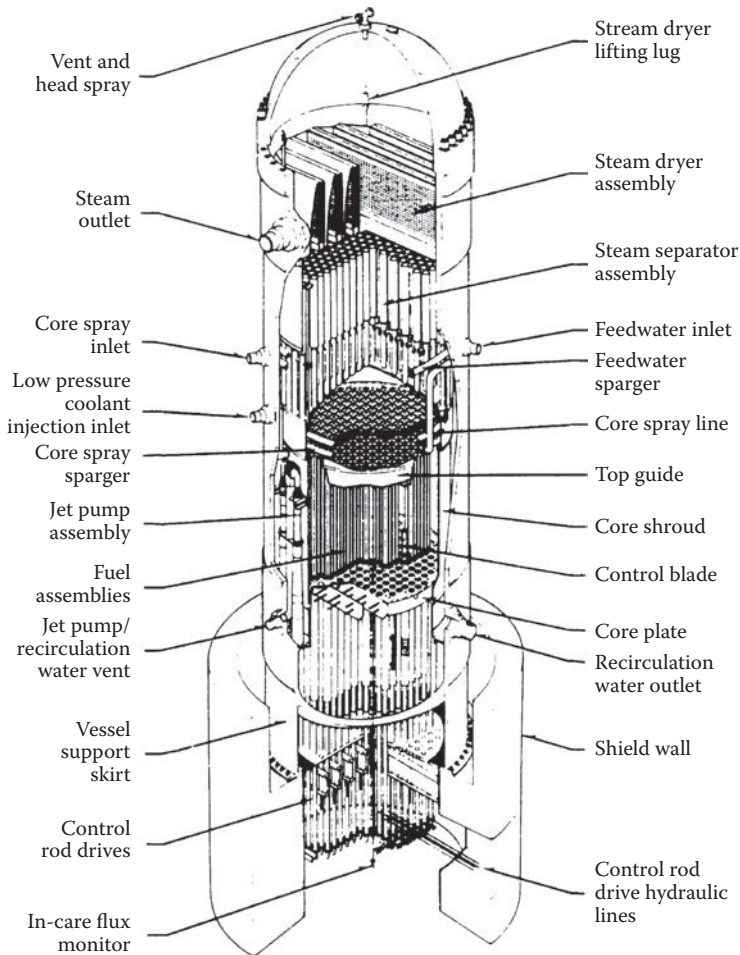
The general arrangement of a PWR power plant is shown in Figure 2.13a. The reactor heats the water from about 550 to approximately 650°F. High pressure, at about 2235 psi, prevents boiling. Pressure is maintained by a pressurizer, and the water is circulated by a pump through a heat exchanger. The heat exchanger evaporates the feedwater and generates steam, which supplies a system similar to a conventional power plant. The advantage of this two-loop system is the separation of the potentially radioactive reactor cooling fluid from the water-steam system.

The reactor core consists of fuel and control rods. Grids hold both the control and fuel rods. The fuel rods are inserted in the grid following a predetermined pattern. The fuel elements are Zircaloy-clad rods filled with  $\text{UO}_2$  pellets. The control rods are made of a silver, cadmium, and indium alloy protected by stainless steel. The reactor operation is controlled by the position of the rods. In addition, control rods are used to shut down the reactor. The rods are released and fall in the core when emergency shutdown is required. Cooling water enters the reactor from the bottom, flows through the core, and is heated by nuclear fission.

In the BWR, shown in Figures 2.13b and 2.14, the pressure is low (about 1000 psi). The nuclear reaction heats the water directly to evaporate it and produce wet steam at about 545°F. The remaining water is recirculated and mixed with feedwater. The steam drives a turbine that typically rotates at 1800 rpm. The



**Figure 2.13** Types of nuclear power plants: (a) pressurized water reactor; (b) boiling-water reactor. (From [3]. Used with permission.)



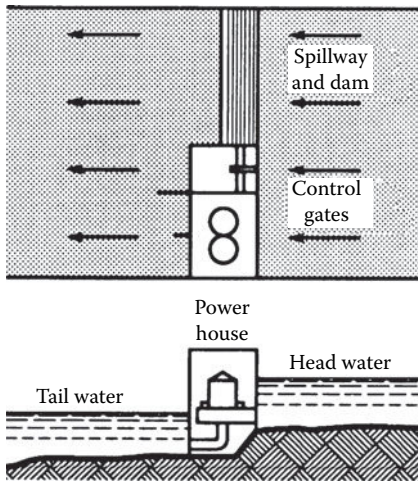
**Figure 2.14** Typical configuration of a boiling-water reactor. (Courtesy of General Electric Company.)

rest of the plant is similar to a conventional power plant. Figure 2.14 shows all the major components of the reactor. The fuel and control rod assembly is located in the lower part. The steam separators are above the core, and the steam dryers are at the top of the reactor. The reactor is enclosed by a concrete dome.

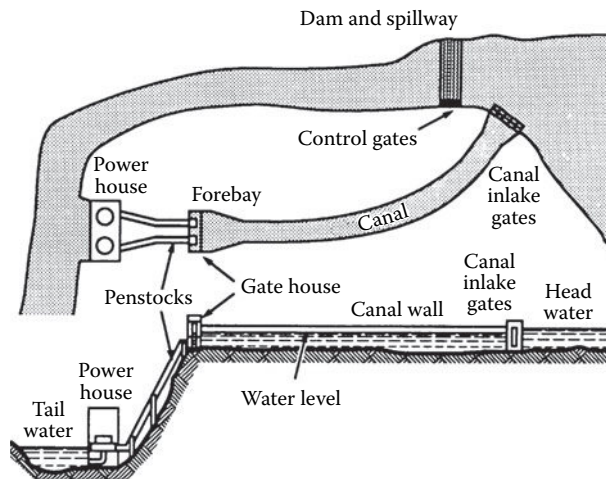
### 2.3.3 Hydroelectric Power Plants

Hydroelectric power plants convert energy produced by a *water head* into electric energy [3]. The head is produced by building a dam across a river, which forms the upper-level reservoir. In the case of *low head*, the water forming the reservoir is fed to the turbine through the intake channel or the turbine is integrated in the dam. The latter arrangement is shown in Figure 2.15. Penstock tubes or tunnels are used for medium-head and high-head plants, as shown in Figure 2.16 and Figure 2.17, respectively. The spillway regulates the excess water in the reservoir by opening gates at the bottom of the dam or permitting overflow on the spillway section of the dam. The water discharged from the turbine flows to the lower or *tail water* reservoir, which is usually a continuation of the original water channel.

High-head plants are built with impulse turbines, where the head-generated water pressure is converted into velocity by nozzles and the high-velocity water jets drive the turbine runner. Low- and medium-head installations are built with reaction-type turbines, where the water pressure is mostly converted to velocity in the turbine. The two basic classes of reaction turbines are the propeller or *Kaplan*



**Figure 2.15** Low-head hydroelectric power plant. (From [4]. Used with permission.)



**Figure 2.16** Medium-head hydroelectric power plant. (From [4]. Used with permission.)

type, mostly used for low-head plants, and the *Francis* type, primarily used for medium-head plants. The cross section of a typical low-head Kaplan turbine is shown in [Figure 2.18](#).

The vertical shaft turbine and generator are supported by a thrust bearing immersed in oil. The generator is in the upper, watertight chamber. The turbine runner has 4 to 10 propeller types and adjustable-pitch blades. The blades are regulated from 5 to 35° by an oil-pressure-operated servomechanism. The water is evenly distributed along the periphery of the runner by a concrete spiral case and regulated by adjustable wicket blades. The water is discharged from the turbine through an elbow-shaped draft tube. The conical profile of the tube reduces the water speed from the discharge speed of 10 to 30 ft/s to 1 ft/s to increase turbine efficiency.

The hydrogenerator is a low-speed (usually 120 to 360 rpm) salient-pole machine with a vertical shaft. The typical number of poles ranges from 20 to 72. They are mounted on a pole spider, which is a welded, spoked wheel. The spider is mounted on the forged steel shaft. The poles are built with a laminated iron core and stranded copper winding. Damper bars are built in the pole faces. The stator is built with a slotted, laminated iron core that is supported by a welded steel frame. Windings are made of stranded conductors insulated between the turns by fiberglass or Dacronglass. The ground insulation is formed from multiple layers of mica tape impregnated with epoxy or polyester resins. Older machines use asphalt and mica tape insulation, which is sensitive to corona-discharge-caused insulation deterioration.

Direct water cooling is used for very large machines, whereas the smaller ones are air- or hydrogen-cooled. Some machines use forced-air cooling with an air-to-water heat exchanger. A braking system is installed in larger machines to stop the generator rapidly when necessary.

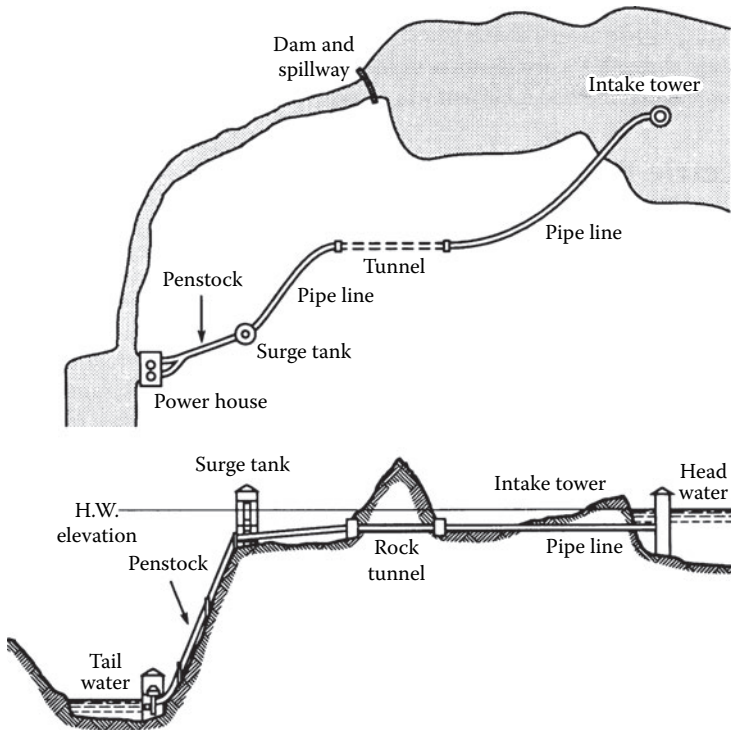


Figure 2.17 High-head hydroelectric power plant. (From [4]. Used with permission.)

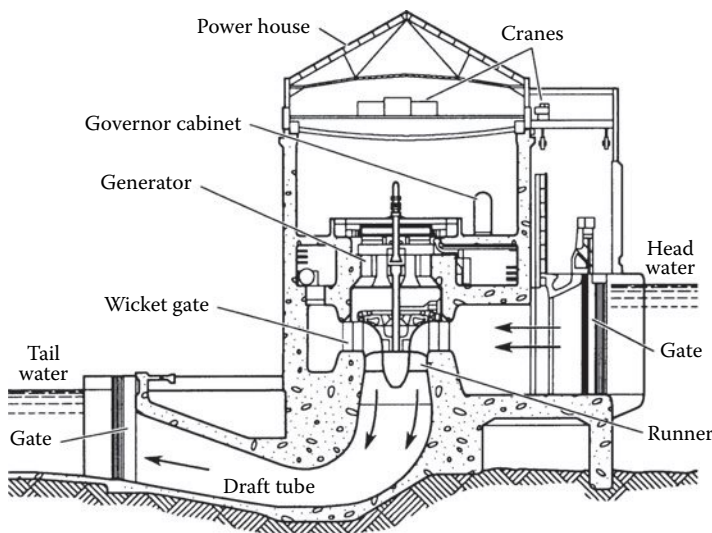


Figure 2.18 Typical low-head hydroelectric power plant with a Kaplan turbine. (From [4]. Used with permission.)

## 2.4 References

---

1. Sankaran, C., "Transformers," in *The Electrical Engineering Handbook*, R. C. Dorf (Ed.), p. 33, CRC Press, Boca Raton, FL, 1993.
2. Stoll, H. G., *Least-Cost Electric Utility Planning*, John Wiley & Sons, New York, 1989.
3. Karady, G., "Conventional Power Generation," in *The Electrical Engineering Handbook*, R. C. Dorf (Ed.), p. 1193, CRC Press, Boca Raton, FL, 1993.
4. Fink, D. G., *Standard Handbook for Electrical Engineers*, McGraw-Hill, New York, 1978.

## 2.5 Bibliography

---

Fardo, S., and D. Patrick, *Electrical Power Systems Technology*, Prentice-Hall, Englewood Cliffs, NJ, 1985.  
Fink D., and D. Christiansen (Eds.), *Electronics Engineers' Handbook*, 3rd ed., McGraw-Hill, New York, 1989.



### 3.1 Introduction

---

*Power factor* (PF) is an important, but often misunderstood, element of ac power system design and operation. It is defined as the ratio of *true power* to *apparent power*, generally expressed as a percentage. (PF also may be expressed as a decimal value.) Reactive loads (inductive or capacitive) act on power systems to shift the current out of phase with the voltage. The cosine of the resulting angle between the current and voltage is the power factor.

### 3.2 Fundamental Principles

---

A utility line that is feeding an inductive load (which is most often the case) is said to have a *lagging* power factor, whereas a line feeding a capacitive load has a *leading* power factor. (See [Figure 3.1](#).) A poor power factor will result in excessive losses along utility company feeder lines because more current is required to supply a given load with a low power factor than the same load with a power factor close to unity.

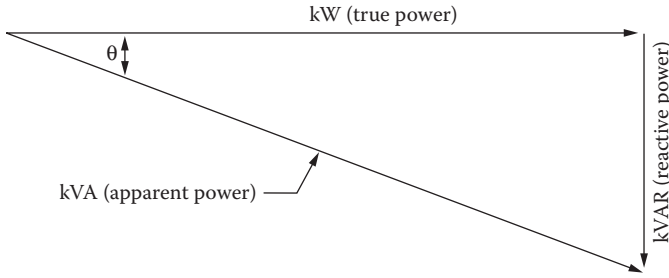
For example, a motor requiring 5 kW from the line is connected to the utility service entrance. If it has a power factor of 86%, the apparent power demanded by the load will be 5 kW divided by 86%, or more than 5.8 kW. The true power is 5 kW, and the apparent power is 5.8 kW. The same amount of work is being done by the motor, but the closer the power factor is to unity, the more efficient the system. To expand upon this example, for a single-phase electric motor, the actual power is the sum of several components, namely:

- The work performed by the system, specifically lifting, moving, or otherwise controlling an object
- Heat developed by the power that is lost in the motor winding resistance
- Heat developed in the motor iron through eddy-current and hysteresis losses
- Frictional losses in the motor bearings
- Air friction losses in turning the motor rotor

All these values are expressed in watts or kilowatts, and can be measured with a wattmeter. They represent the actual power. The apparent power is determined by measuring the current and voltage with an ammeter and a voltmeter, then calculating the product of the two. In the single-phase motor example, the apparent power thus obtained is greater than the actual power. The reason for this is the power factor.

The PF reflects the differences that exist between different types of loads. A soldering iron is a purely resistive load that converts current directly into heat. The current is called actual current because it contributes directly to the production of actual power. On the other hand, single-phase electric motor represents a partially inductive load. The motor current consists of actual current that is converted into actual power and a *magnetizing current* that is used to generate the magnetic field required for operation of the device. This magnetizing current corresponds to an exchange of energy between the power source and the motor, but it is not converted into actual power. This current is identified as the reactive current in the circuit.

As illustrated in [Figure 3.2](#), in a resistive circuit, the current is in phase with the voltage. In a purely inductive circuit, the current lags the voltage by 90°. This relationship can be represented graphically by vectors, as shown in the figure. For a circuit with both inductive and resistive components, as in the motor example, the two conditions exist simultaneously. The distribution between the actual power and the reactive power is illustrated in [Figure 3.3](#). The power factor, which has been defined previously as the ratio between actual power and apparent power, is also the cosine of the angle  $\theta$ . The greater the angle  $\theta$  becomes, the lower the power factor.



$$\cos \theta = \frac{\text{kW}}{\text{kVA}} = \text{PF}$$

$$\sin \theta = \frac{\text{kVAR}}{\text{kVA}}$$

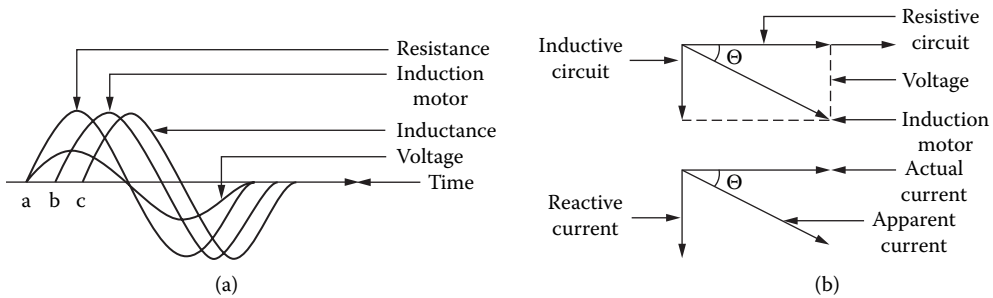
$\theta$  = The phase angle, a measure of the net amount of inductive reactance in the circuit.

kW = The true power that performs the “real work” done by the electrical circuit (measured in kilowatts).

kVA = The apparent power drawn by a reactive load (measured in kilowatts).

kVAR = The kilovolt-amperes-reactive component of an inductive circuit. The kVAR component (also known as the *phantom power*) provides the magnetizing force necessary for operation of inductive loads.

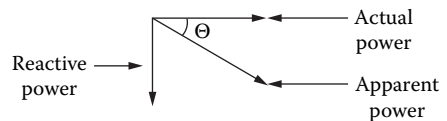
**Figure 3.1** The mathematical relationships of an inductive circuit as they apply to power factor (PF) measurements. Reducing the kVAR component of the circuit causes  $\theta$  to diminish, improving the PF. When kW is equal to kVA, the phase angle is zero and the power factor is unity (100%).



**Figure 3.2** The effects of inductance in a circuit: (a) waveforms for resistive and inductive loads; (b) vector diagrams of inductive loads.

Determining the power factor for a given element of a power-distribution system is complicated by the variety of loads typically connected. Different loads present different PF components:

- **Lighting.** The PF for most incandescent lamps is unity. Fluorescent lamps usually have a low power factor; 50% is typical. Fluorescent lamps sometimes are supplied with compensation devices to correct for low power factor. Mercury vapor lamps have a low PF; 40 to 60% is typical. Again, such devices can be supplied with compensation devices.
- **Electric motors.** The PF of an induction motor varies with the load, as shown in [Figure 3.4](#). Unloaded or lightly loaded motors exhibit a low PF. [Figure 3.5](#) illustrates the variation of PF and reactive power for varying loads on a three-phase induction motor. Synchronous motors provide



**Figure 3.3** Vector diagram showing that apparent power is the vector sum of the actual and the reactive power in a circuit.



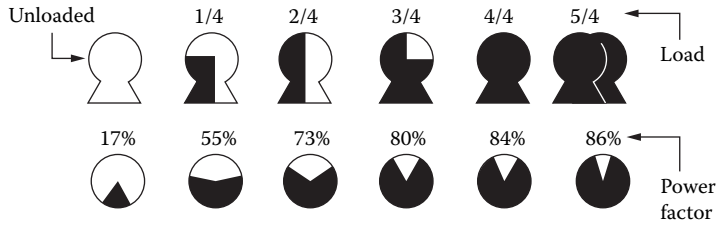


Figure 3.4 Changes in power factor for an induction motor as a function of motor loading.

good PF when their excitation is adjusted properly. Synchronous motors also can be *overexcited* to exhibit a leading power factor and, therefore, can be used to improve the power factor of a facility.

- **Heating systems.** Most heating systems used in ovens or dryers present a PF of close to unity.
- **Welding equipment.** Electric arc welders usually have a low PF; 60% is typical.
- **Distribution transformers.** The PF of a transformer varies considerably as a function of the load applied to the device, as well as the design of the transformer. An unloaded transformer would be highly inductive and, therefore, would exhibit a low PF.

Power factor, in the classical power triad representation presented here, is more appropriately referred to as *displacement power factor* (DPF). DPF is that portion of the power factor that is attributable to phase displacement between the source voltage and the load current at the fundamental frequency [1]. The vector diagram power triangle models real and reactive power at the fundamental frequency of the electrical power system. Displacement power factor does not consider that portion of the power factor attributable to harmonic load current.

The *total power factor* (TPF) can be derived by revisiting the definition of power factor as a measurement of efficiency. TPF, then, is the ratio of real power to total power consumed in the system:

$$TPF = \frac{KW}{kVA_{total}} \tag{3.1}$$

where

TPF = Total power factor

KW = Real power consumed by the electrical system

kVA<sub>total</sub> = Total power (composed of real, reactive, and harmonic power)

The TPF in a system can be low because of high reactive power consumption or high harmonic power consumption, resulting in high apparent power in the denominator. DPF is always greater than TPF when harmonic load currents exist.

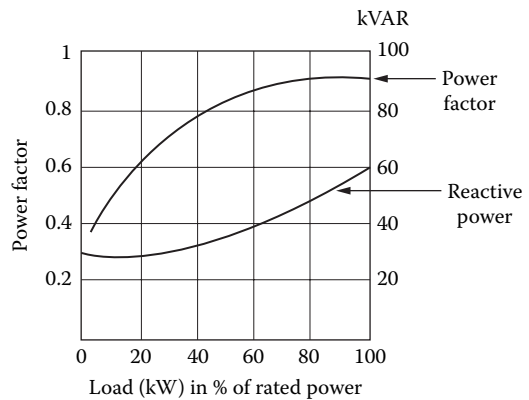


Figure 3.5 The relationship of reactive power and power factor to percentage of load for a 100 kW, three-phase induction motor.

### 3.3 PF Correction Techniques

The term *compensation* is used to describe the intentional insertion of reactive power devices, either capacitive or inductive, to achieve one or more desired effects in an electric power system. These effects include improved voltage profiles, enhanced stability, and increased transmission capacity. The devices are either in series or in shunt (parallel) with the load(s) at one or more points in the power circuit.

To keep the power factor as close as possible to 100%, utility companies place capacitor banks in parallel with the load at various locations in the distribution system, offsetting the inductive loading (lagging power factor) of most user equipment. The goal is to create an equal amount of leading PF in the system to match the lagging PF of the load. When balanced, the power factor is 100%. In practice, this is seldom attainable because loads are switched on and off at random times, but utilities routinely maintain an overall power factor of approximately 99%. To accomplish this, capacitor banks are switched automatically to compensate for changing load conditions. In addition, *static capacitors* are used for power factor correction. These devices are similar to conventional oil-filled, high-voltage capacitors. Operating voltages range from 230 V to 13.8 kV and higher for pole-mounted applications.

The PF correction capacitors are connected in parallel, with the utility lines as close as practical to the low-PF loads. The primary disadvantage of static PF correction capacitors is that they cannot be adjusted for changing power factor conditions. Remotely operated relays can be used, however, to switch capacitor banks in and out of the circuit as required. Synchronous capacitors, on the other hand, can be adjusted to provide varying capacitance to correct for varying PF loads. The capacitive effect of a synchronous capacitor is changed by varying the dc excitation voltage applied to the rotor of the device.

Utilities usually pass on to customers the costs of operating low-PF loads. Power factor can be billed as one, or a combination, of the following:

- A penalty for PF below a predetermined value or a credit for PF above a predetermined value
- An increasing penalty for decreasing PF
- A charge on monthly kVAR hours
- A straight charge for the maximum value of kVA used during the month

Aside from direct costs from utility companies for low-PF operation, the end user experiences a number of indirect costs, as well. When a facility operates with a low overall PF, the amount of useful electrical energy available inside the plant at the distribution transformer is reduced considerably because of the amount of reactive energy that the transformer(s) must carry. Figure 3.6 illustrates the reduction in available power from a distribution transformer when presented with varying PF loads. Figure 3.7 illustrates the increase in  $I^2R$  losses in feeder and branch circuits with varying PF loads. These conditions result in the need for oversized cables, transformers, switchgear, and protection circuits.

The *copper losses* in a system are proportional to the square of the load current. The installation of PF correction capacitors near offending low PF loads decreases the reactive power and load current drawn from the utility [17]. This reduced load current translates into lower conductor losses throughout the electrical system. As copper losses are reduced, voltage levels increase throughout the system. This rise can be described by

$$VR = \frac{kVAR_{cb} \times Z_t}{kVA_t} \quad (3.2)$$

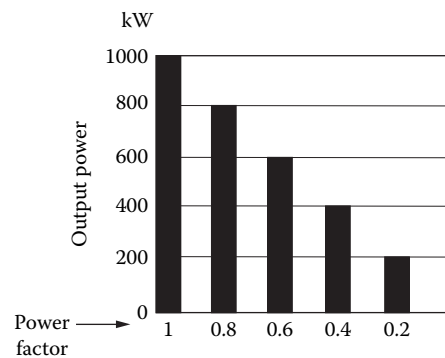


Figure 3.6 The effects of power factor on the output of a transformer.

where

- VR = percent voltage rise
- $kVAR_{cb}$  = sum of capacitor kVAR ratings
- $Z_t$  = percent reactance of the supply transformer(s)
- $kVA_t$  = kVA rating of the supply transformer(s)

When individual capacitors are installed at large motors or at a motor control center with several smaller motors attached, the individual capacitor reactive power ratings can be arithmetically summed and the resulting value inserted into Equation 3.2.

### 3.3.1 On-Site Power Factor Correction

The first step in correcting for low PF is to determine the existing situation at a given facility. Clamp-on power factor meters are available for this purpose. Power factor can be improved in two ways:

- Reduce the amount of reactive energy by eliminating low PF loads, such as unloaded motors and transformers
- Apply external compensation capacitors or other devices to correct the low-PF condition

PF correction capacitors perform the function of an energy-storage device. Instead of transferring reactive energy back and forth between the load and the power source, the magnetizing current reactive energy is stored in a capacitor at the load. Capacitors are rated in kVARs, and are available for single- and multiphase loads. Usually, more than one capacitor is required to yield the desired degree of PF correction. The capacitor rating required in a given application can be determined by using lookup tables provided by PF capacitor manufacturers. Installation options include:

- Individual capacitors placed at each machine
- A group or bank installation for an entire area of the plant
- A combination of the two approaches

Figure 3.8a shows a simple circuit with shunt capacitor compensation applied at the load. The line current  $I_L$  is the sum of the motor load current  $I_M$  and the capacitor current  $I_C$ . From the current phasor diagram of Figure 3.8b, it can be seen that the line current is reduced with the insertion of the shunt capacitor. Figure 3.8c displays the corresponding voltage phasors. The effect of the shunt capacitor is to increase the voltage source to  $V_{S1}$  from  $V_{S0}$ .

When rectifier loads that generate harmonic load current are the cause of a low-PF condition, the addition of PF correcting capacitors will not necessarily provide the desired improvement. The capacitors, in some cases, may actually raise the line current and fail to improve the power factor. Harmonic currents generally are most apparent in the neutral of three-phase circuits. Conductors supplying three-phase rectifiers using a neutral conductor require a neutral conductor that is as large as the phase conductors. A reduced neutral should not be permitted. When adding capacitors for PF correction, be careful to avoid any unwanted voltage resonances that might be excited by harmonic load currents.

If a delta/wye-connected power transformer is installed between the power source and the load, the power factor at the transformer input generally will reflect the average PF of the load on the secondary. This conclusion works on the assumption that the low PF is caused by inductive and capacitive reactances in the loads. However, if the load current is rich in harmonics from rectifiers and switching regulators, some of the harmonic currents will flow no farther toward the power source than the transformer delta winding. The third harmonic and multiples of three will flow in the delta winding and will be significantly reduced in amplitude. By this means, the transformer will provide some improvement in the PF of the total load.

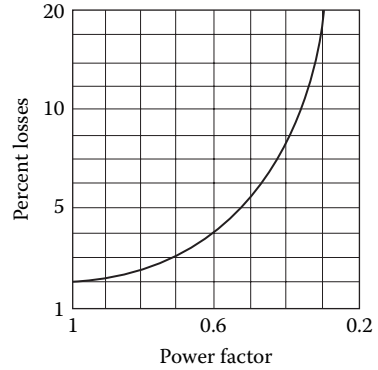
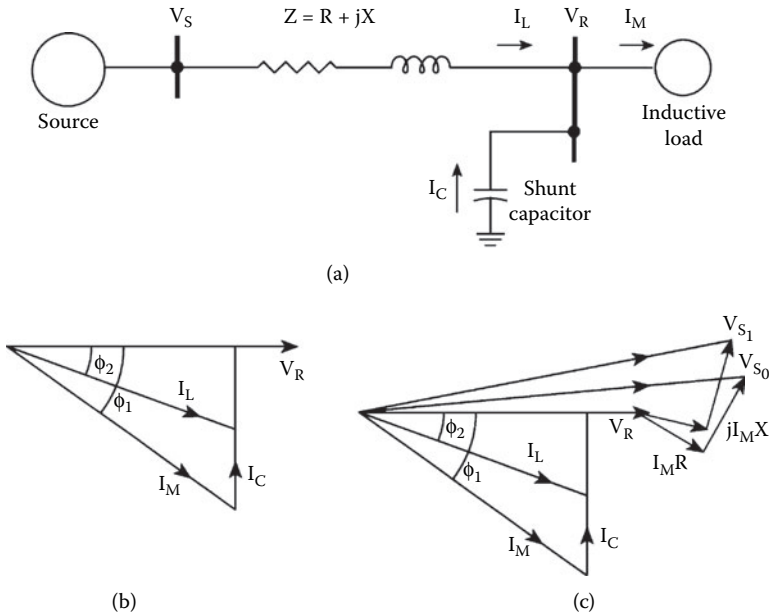


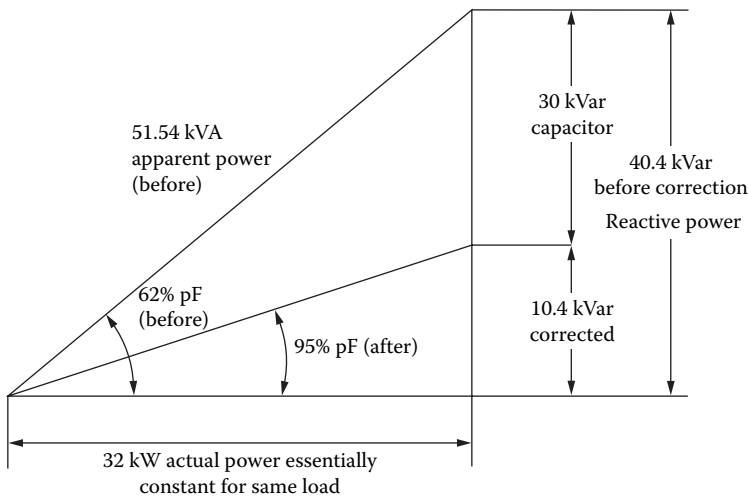
Figure 3.7 The relationship between power factor and percentage losses in system feeder and branch circuits.



**Figure 3.8** Shunt-capacitor compensation: (a) schematic diagram; (b) current phasor diagram; (c) voltage phasor diagram. (From [1]. Used with permission.)

An economic evaluation of the cost versus benefits, plus a review of any mandatory utility company limits that must be observed for PF correction, will determine how much power factor correction, if any, may be advisable at a given facility. Figure 3.9 shows a “before” and “after” comparison of a hypothetical facility. Correction to 85% will satisfy many requirements. No economic advantage is likely to result from correcting to 95% or greater. Overcorrecting a load by placing too many PF correction capacitors can reduce the power factor after reaching unity and cause uncontrollable overvoltages in low-kVA-capacity power sources.

PF correcting capacitors usually offer some benefits in absorbing line-voltage impulse-type noise spikes. However, if the capacitors are switched on and off, they will create significant impulses of their own. Switching can be accomplished with acceptably low disturbance using soft-start or preinsertion



**Figure 3.9** Illustration of the results of on-site power factor correction.

resistors. Such resistors are connected momentarily in series with the capacitors. After a brief delay (0.5 s or less), the resistors are short-circuited, connecting the capacitors directly across the line.

Installation of PF correction capacitors at a facility is a complicated process that requires a knowledgeable consultant and licensed electrician. The local utility company should be contacted before any effort is made to improve the PF of a facility.

### 3.3.2 Shunt Reactors

Shunt reactor compensation is typically required under conditions that are the opposite of those requiring shunt capacitor compensation [1]. Such a case is illustrated in Figure 3.10. Shunt reactors are usually installed to remedy utility company power-generation and transmission issues, including the following:

- Overvoltages that occur during low load periods at utility substations served by long lines as a result of the inherent capacitance of the line
- Leading power factors at generating plants resulting in lower transient and steady-state stability limits
- Open-circuit line charging kVA requirements in extra-high-voltage systems that exceed the available generation capabilities

It should also be noted that coupling from nearby energized lines can cause severe resonant overvoltages across the shunt reactors of unenergized compensated lines.

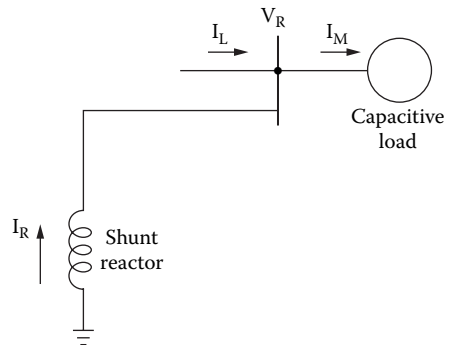


Figure 3.10 Shunt-reactor-compensated load. (From [1]. Used with permission.)

### 3.3.3 Unwanted Resonance Conditions

At a specific frequency, the inductive reactance of an electrical distribution system will equal the capacitive reactance; this is the definition of resonance. Resonance takes on one of two forms, parallel or series, depending upon the circuit configurations. The application of PF correction capacitors at a facility must be carefully planned to avoid unwanted harmonic resonances in the ac distribution system [2].

When a system is in parallel resonance, the impedance of the transformer and capacitor is maximized. Harmonic currents at or near the resonant frequency can create high harmonic voltages across the high parallel impedance. When a system is in series resonance, the impedance of the transformer and capacitor is minimized. During series resonance, the only impedance to current flow is the pure resistance of the distribution circuit, which is normally quite low.

Nonlinear loads often behave as harmonic current generators, operating on the 60 Hz source voltage and producing harmonic-rich disturbances on the distribution system. By spreading the load current across the harmonic spectrum, nonlinear loads significantly increase the likelihood of resonances within a distribution system that includes PF correction capacitors. High harmonic voltages and currents can result, therefore, from nonlinear load operation that excites a resonant condition.

Harmonic-related problems include overheating of equipment, blown fuses, and equipment failure. Excessive harmonic voltages and current in capacitors results in increased losses in iron, insulation, and conductors, with a corresponding increase in temperature [3].

Simple equations can be used to determine whether the installation of capacitors on an electrical distribution system might lead to a resonant condition. The short-circuit kVA available from the utility must be determined first, and is given by

$$kVA_{sc} = \frac{\sqrt{3} \times V \times I}{1000} \quad (3.3)$$

where

$kVA_{sc}$  = The available short-circuit kVA from the utility

$V$  = System operating voltage

$I$  = Available short-circuit current

Next, the building or facility distribution system short-circuit capacity must be calculated, as given by

$$kVA_{sys} = \frac{kVA_t \times kVA_{sc}}{kVA_t + (Z \times kVA_{sc})} \quad (3.4)$$

where

$kVA_{sys}$  = The short circuit capacity of the secondary electrical system

$kVA_t$  = kVA rating of the substation transformer(s)

$kVA_{sc}$  = Available short-circuit kVA from the utility

$Z_t$  = Impedance of the substation transformer(s)

The resonant harmonic of the distribution system under analysis is given by

$$h_r = \sqrt{\frac{kVA_{sys} + kVA_{mc}}{kVAR_c}} \quad (3.5)$$

where

$h_r$  = The resonant harmonic

$kVA_{sys}$  = Available short-circuit kVA from the distribution system

$kVA_{mc}$  = available short-circuit kVA from motor contribution

$kVAR_c$  = sum of capacitor kVAR ratings

A resonant harmonic on the order of 50 or greater does not usually represent a potential resonant condition; because the distribution-system inductive reactance increases proportionally with frequency, higher order harmonic currents are significantly attenuated. Additionally, harmonic analysis may reveal negligible harmonic current magnitudes at or near the resonant frequency. In either case, harmonic mitigation techniques may not be required to prevent resonance within the distribution system.

When Equation 3.5 indicates a relatively low resonant harmonic, and spectrum analyses indicate that the magnitude of harmonic currents are significant at or near the resonant frequency, the most likely solution will be to install harmonic filters. In fact, low total power factor (TPF) can be principally the result of harmonic currents generated by the load. In such instances, the TPF may be improved by installing filters or traps alone [4]. In most cases, a combination of harmonic filters and capacitors designed to operate at the fundamental frequency are required to improve the TPF to acceptable levels in systems in which harmonic currents are present.

Active harmonic filters are available for facility applications that sense the load parameters and inject currents onto the distribution system that cancel the harmonics generated by nonlinear loads. In lieu of active filters, strategic placement of static filters to trap harmonics near the resonant frequency and to attenuate higher order harmonics can effectively protect the entire electrical system from damaging harmonic current and voltage magnitudes. Capacitor banks can be specified as integral components of a harmonic filter, tuned at or near the resonant frequency. Harmonic filters may provide a single package that will mitigate distribution-system resonant frequency problems and simultaneously improve the total power factor [4, 5].

### 3.3.4 Series Capacitor Compensation

Series capacitors are employed to neutralize part of the inductive reactance of a power circuit [1]. (See [Figure 3.11](#).) From the phasor diagram of [Figure 3.12](#), it can be seen that the load voltage is higher with the capacitor inserted than without the capacitor. Such application of a series capacitor facilitates an increase in the circuit transmission capacity and enhanced stability of the distribution network. Other useful by-products include:

- Improved load distribution
- Control of overall transmission losses
- Control over reactive power throughout the system

It should be noted, however, that the reduction in the circuit inductive reactance gained through the use of series-capacitor-compensation also increases the short-circuit current levels over those for the noncompensated system.

Another consideration involves the interaction between a series-capacitor-compensated ac transmission system in electrical resonance and a turbine-generator mechanical system in torsional mechanical resonance. These resonances result in the phenomenon of *subsynchronous resonance* (SSR). In this mode, energy is exchanged between the electrical and mechanical systems at one or more natural frequencies of the combined system below the synchronous frequency of the system. The resulting mechanical oscillations can increase until mechanical failure occurs. A number of measures can be taken to reduce or eliminate SSR, as described in Reference 1.

### 3.3.5 Static Compensation Devices

Advances in thyristor technology for power-system applications have led to the development of the *static VAR compensator* (SVC) [1]. This class of devices contains standard shunt elements (reactors and capacitors) that are controlled by thyristors. Static VAR devices are used to address two common problems encountered in practical power systems:

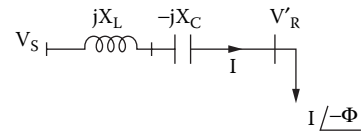
- Load compensation, where there is a need to reduce or cancel the reactive power demand of large and fluctuating industrial loads. Because heavy industrial loads are normally concentrated in one plant and served from one network terminal, they can usually be handled by a local compensator connected to the same terminal.
- Balancing the real power drawn from the ac supply lines. This type of compensation is related to the voltage support of transmission lines at a given terminal in response to disturbances of both the load and the supply. This voltage support is achieved by rapid control of the SVC reactance and, thus, its reactive power output.

The main objectives of such VAR compensation schemes are:

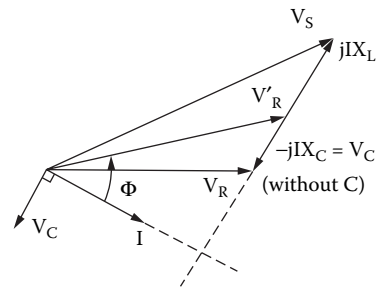
- To increase the stability limit of the ac power system
- To decrease terminal voltage fluctuations during load changes
- To limit overvoltages resulting from large system disturbances

SVCs are essentially thyristor-controlled reactive power devices, usually designed around one of two basic configurations:

- *Thyristor-switched shunt capacitor* (TSC). As illustrated in Figure 3.13a, this configuration splits a capacitor bank into small steps and switches those steps on and off individually. This approach offers stepwise control, virtually no transients, and no harmonic generation. The average delay for executing a command from the regulator is one half-cycle.
- *Thyristor-switched shunt reactor* (TSR). Shown in Figure 3.13b, the fundamental frequency current component through the reactor is controlled by delaying the closing of the thyristor switch with respect to the natural zero crossing of the current. In this case, harmonic currents are generated from the phase-angle-controlled device.



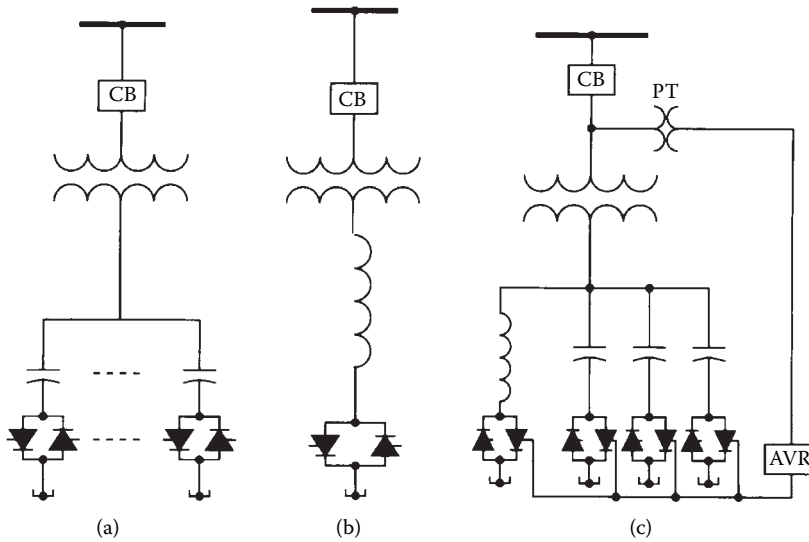
**Figure 3.11** A distribution line with series-capacitor-compensation applied. (From [1]. Used with permission.)



**Figure 3.12** Phasor diagram corresponding to the circuit shown in Figure 3.11. (From [7]. Used with permission.)



In many applications, the arrangement of the SVC consists of a few large steps of thyristor-switched capacitors and one or two thyristor-controlled reactors, as shown in Figure 3.13c.



**Figure 3.13** Basic static VAR compensator configurations: (a) thyristor-switched shunt capacitors (TSC); (b) thyristor-switched shunt reactors (TSRs); (c) combined TSC/TSR. (From [1]. Used with permission.)

### 3.4 References

1. El-Hawary, M. E., "Compensation," in *The Electrical Engineering Handbook*, R. C. Dorf (Ed.), p. 1244, CRC Press, Boca Raton, FL, 1993.
2. Massey, G. W., "Power Factor Improvement Capacitors: The Balance Between Power Quality and Energy Efficiency," in *Power Quality Solutions/Alternative Energy*, Powersystems World '96, Intertec International, Ventura, CA, p. 34, 1996.
3. Rice, Da. E., "Adjustable Speed Drive and Power Rectifier Harmonics — Their Effect on Power Systems Components," *IEEE Transactions on Industry Applications*, Vol. IA-22, No. 1, IEEE, New York, NY, January/February 1986.
4. Lowenstein, M. Z., "Power Factor Improvement for Non-Linear Loads," *1991 Annual Technology Conference of the Textile, Fiber, and Film Industry Committee*, Industry Applications Society of the IEEE, Greenville, SC, May 1991.
5. Morgan, R. B., "Improving Power Factor for Greater Efficiency — Part 2," *Electrical Construction & Maintenance*, PRIMEDIA Intertec, Overland Park, KS, November 1994.

### 3.5 Bibliography

- Acard, C., "Power Factor Measurement and Correction," *Plant Electrical Systems*, PRIMEDIA Intertec, Overland Park, KS, March 1981.
- Fardo, S., and D. Patrick, *Electrical Power Systems Technology*, Prentice-Hall, Englewood Cliffs, NJ, 1985.
- Fink D., and D. Christiansen (Eds.), *Electronics Engineers' Handbook*, 3rd ed., McGraw-Hill, New York, 1989.
- Jay, F., *IEEE Standard Directory of Electrical and Electronics Terms*, 3rd ed., IEEE, New York, 1984.
- Kramer, R. A., "Analytic and Operational Consideration of Electric System Reliability," *Proceedings of the Reliability and Maintainability Symposium*, IEEE, New York, 1991.
- Redl, R., P. Tenti, and J. D. Van Wyk, "Power Electronics' Polluting Effects," *Spectrum*, IEEE, New York, p. 33, May 1997.



# Power Transformers

---

## 4.1 Introduction

---

The transformer forms the basis of all ac power-distribution systems. In the most basic definition, a transformer is a device that magnetically links two or more circuits for time-varying voltage and current. Magnetic coupling has a number of intrinsic advantages, including:

- DC isolation between the circuits
- The ability to match the voltage and current capability of a source to a load
- The ability to change the magnitude of the voltage and current from one side of the transformer to the other
- The ability to change the phases of voltage and current from one side of the device to the other

## 4.2 Inductive Properties<sup>1</sup>

---

Inductance is, primarily, a geometrical property of a current-carrying element in an electrical circuit [1]. A circuit element with this property may be termed an *inductor*. The magnitude and, for that matter, the frequency dependence of inductance also depend on the material environment of that element. Similar remarks to these could — of course — be used to define capacitance; inductance and capacitance are invariably intimately related in electronic circuits. One reason is that both are (electrical) energy storage devices in time-varying electronic systems. Capacitance is, however, a measure of the capability of a (potential) circuit element to store charge and, thereby, electric field energy; inductance, by contrast, is a measure of a circuit element's ability to store magnetic field energy. Because a magnetic field is derived from current flow, inductance is always associated with current-carrying circuit elements. This dichotomy extends also to the matter of frequency dependence. At zero signal frequency, for example, an (ideal) capacitor has infinite impedance, whereas the inductor has zero impedance; at infinite frequency, the opposite is true.

The concept of inductance or, more correctly, *self-inductance* is, perhaps, best illustrated by the example of a current-carrying conducting coil of  $N$  circular turns (see Figure 4.1). When a current  $I$  flows through this circuit, as described, a magnetic field is generated inside and around the coil turns, in accordance with Ampere's law. Flux linkage  $\Lambda$  is defined by how much of the total magnetic flux  $\phi$  threads all of the turns of the coil, multiplied by the total numbers of turns  $N$ . Thus, in simple algebraic terms:

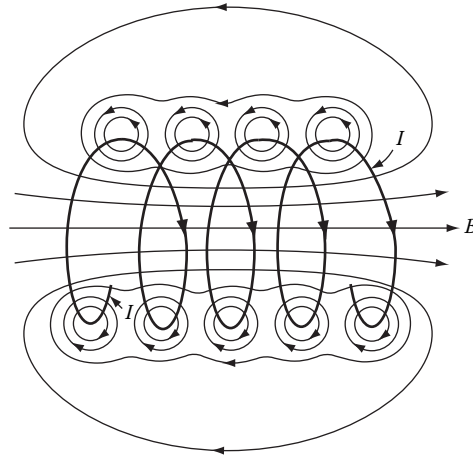
$$\Lambda = N\phi = N \iint_A B \, dA \quad (\approx N B A) \quad (4.1)$$

where, because of incomplete linkage by the magnetic flux, in actuality  $A$  will typically be slightly less than the cross-sectional area of the coils. The inductance  $L$  of this coil is defined as the flux linkage per unit current and is defined as [2]

$$L = \frac{\Lambda}{I} = \frac{N \left( \iint_A B \, dA \right)}{I} \quad (4.2)$$

---

<sup>1</sup>This section was adapted from Parker, M. R., and W. E. Webb, "Magnetic Materials for Inductive Processes," in *The Electronics Handbook*, 2nd ed., J. C. Whitaker (Ed.), CRC Press, Boca Raton, FL, 2005. Used with permission.



**Figure 4.1** A magnetic field produced by a current through a coil. (After [2]. From [1]. Used with permission.)

The SI unit of inductance is the *henry* (H) if  $I$  is in amperes,  $\Lambda$  in webers,  $A$  in square meters, and  $B$  in teslas (webers/square meter). The inductance of some current-carrying elements of comparatively simple geometry is described in approximate form next.

### 4.2.1 Coils

The long solenoid is a longer, more tightly wound version of the simple coil shown in Figure 4.1 with a relatively large number of turns, as illustrated in Figure 4.2 [1]. The  $B$ -field inside a long solenoid is fairly uniform and given by

$$\frac{\mu_0 NI}{l} \quad (4.3)$$

where  $l$  is its length. The inductance is given by

$$L = \frac{\mu_0 N^2 A}{l} \quad (4.4)$$

where  $\mu_0 = 4\pi \times 10^{-7} \text{ H/m}$  is the *permeability* of free space.

Similarly, for a short solenoid of  $N$  turns, also of length  $l$  and of radius  $a$ , it can be shown that

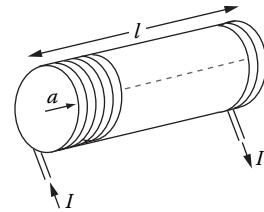
$$B = \frac{\mu_0 NI}{(l^2 + 4a^2)^{1/2}} \quad (4.5)$$

Once again, from Equation 4.3 and Equation 4.5, it follows that

$$L = \frac{\mu_0 N^2 A}{(l^2 + 4a^2)^{1/2}} \quad (4.6)$$

Note that, in the limit of  $a$  becoming vanishingly small, the short solenoid takes on the appearance of a long solenoid and Equation 4.6 reduces to Equation 4.4.

In the limit of  $l$  approaching zero in Equation 4.6, we have a flat coil of  $N$  turns, radius  $a$ , whose inductance is approximately



**Figure 4.2** A long solenoid. (From [1]. Used with permission.)

$$L = \frac{\mu_0 N^2 a}{2} \tag{4.7}$$

where  $A$  (Equation 4.6) has been replaced by  $a$ . Note that the special case of a single loop is derived from Equation 4.7, simply by making  $N = 1$ , leading to

$$L = \frac{\mu_0 a}{2} \tag{4.8}$$

### 4.2.2 The Toroid

Another simple classic geometry (Figure 4.3) is the toroid [1]. This doughnut-shaped winding is a close relative of the long solenoid. Indeed, it may be viewed as a long solenoid whose ends have been joined. Accordingly, the  $B$ -field inside the toroid may be given, approximately, by Equation 4.4, with the modification that the length  $l$  is replaced by  $2\pi r$ , where  $r$  is the (mean) radius of the toroid. A crude approximation for the inductance of the toroid, when  $r$  is much greater than the radius of the individual windings, is, therefore,

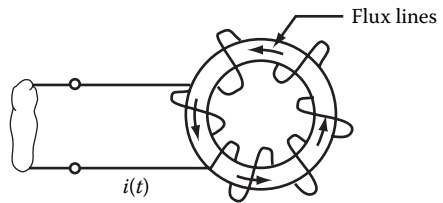


Figure 4.3 A toroid inductor. (After [3]. From [1]. Used with permission.)

$$L = \frac{\mu_0 N^2 A}{2\pi r} \tag{4.9}$$

When the dimensions of the windings compare in size with the toroid radius, the simple expression of Equation 4.9 is inadequate. To illustrate the point, consider the rectangularly cross-sectioned toroid of Figure 4.4. It is easy to show analytically [4] that, for this geometry,

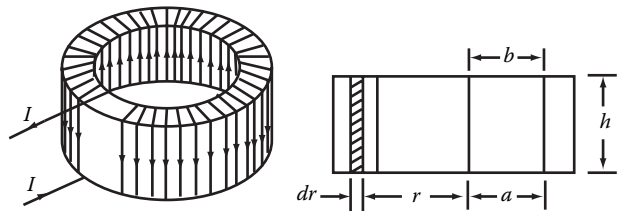


Figure 4.4 A closely wound toroidal coil. (After [4]. From [1]. Used with permission.)

$$L = \frac{\mu_0 N^2 h (lnb / a)}{2} \tag{4.10}$$

### 4.2.3 Circuit Description of Self-Inductance

It is a relatively simple matter to describe the voltage drop across a simple self-inductance such as the coil of Figure 4.5. For a steady-state current  $I$ , in the coils, the voltage drop is simply  $IR$ , as dictated by Ohm's law, where  $R$  is the coil resistance. On the other hand, if the current  $i(t)$  is time varying, then it follows quite simply from a combination of Faraday's law of electromagnetic induction and equations for magnetic flux and flux density that the (time-varying) voltage drop  $v$  across a self-inductance is

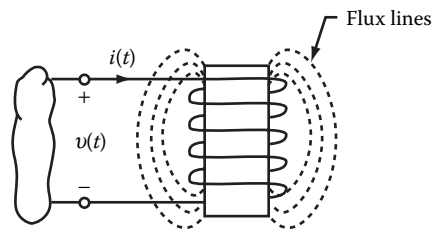


Figure 4.5 A circuit illustrating self-inductance (After [3]. From [1]. Used with permission.)

$$v = L \frac{di}{dt} + Ri \tag{4.11}$$

Given that magnetic field energy density is expressible [2] as

$$w_m = B \times H \quad (4.12)$$

it follows that for any of the simple inductive windings described, the total magnetic field energy (that is, the stored energy of any inductor) is

$$W_m = \frac{1}{2} Li^2 \quad (4.13)$$

Note that  $L$  may be defined from Equation 4.13, thus,

$$L = \left( \frac{2W_m}{i^2} \right)^{1/2} \quad (4.14)$$

#### 4.2.4 Magnetic Materials

All of the preceding described current elements were characterized by air-filled windings [1]. In fact, the formulas of the preceding equations are essentially valid if the windings encompass any condensed matter other than a magnetic (i.e., ferromagnetic/ferrimagnetic, etc.) material. If, however, any of the described windings are constructed around a magnetic material of *permeability*  $\mu$ , then in each of the formulas of Equation 4.4 through Equation 4.10,  $\mu_0$  is replaced by  $\mu$ . Now, for magnetic materials  $\mu$  is, typically, much greater than  $\mu_0$ . The actual value of  $\mu$  depends crucially on: (1) the current signal frequency, and (2) the chemical identity and temperature of the magnetic material comprising the inductive element as well as on the details of its microstructure.

In inductive devices, one will typically find *soft* magnetic materials employed as the core medium. Here, a soft magnetic material is one in which the *relative permeability*  $\mu_r$ , defined as

$$\mu_r = \frac{\mu}{\mu_0} \quad (4.15)$$

is, numerically,  $\gg 1$ . (See Table 4.1.) For the magnetic materials of Table 4.1 and the like,  $\mu_r$  is: (1) a nonanalytical function of magnetic field intensity (see, for example Figure 4.6), and (2) a complex quantity of the form

$$\mu = \mu' + j\mu'' \quad (4.16)$$

where  $\mu''$  is, typically, significant only at high frequencies.

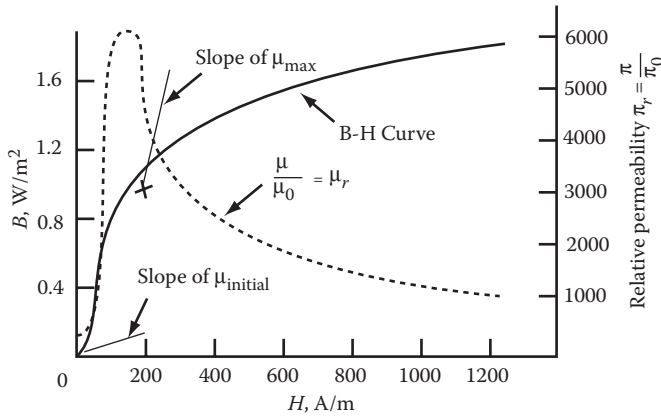
### 4.3 Basic Principles of the Transformer

In 1831, English physicist Michael Faraday demonstrated the phenomenon of electromagnetic induction. The concept is best understood in terms of lines of force, a convention Faraday introduced to describe the direction and strength of a magnetic field. The lines of force for the field generated by a current in a loop of wire are shown in Figure 4.7. When a second, independent loop of wire is immersed in a changing magnetic field, a voltage will be induced in the loop. The voltage will be proportional to the time rate of change of the number of force lines enclosed by the loop. If the loop has two turns, such induction occurs in each turn, and twice the voltage results. If the loop has three turns, three times the voltage results, and so on. The concurrent phenomena of *mutual induction* between the coils and *self-induction* in each coil form the basis of transformer action.

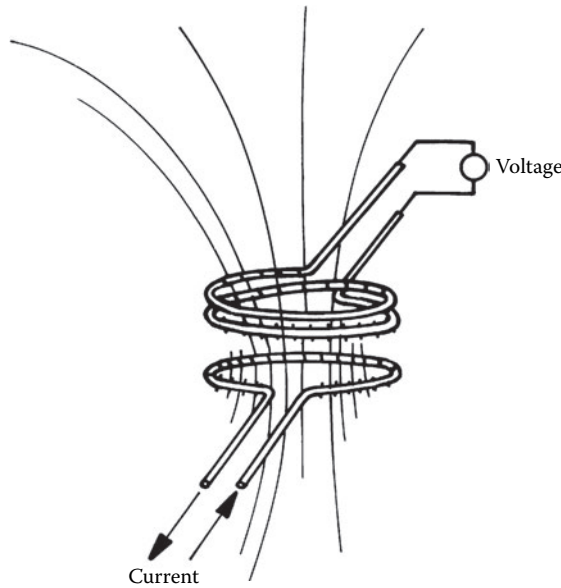
For a power transformer to do its job effectively, the coils must be coupled tightly and must have high self-induction. That is, almost all the lines of force enclosed by the primary also must be enclosed by the secondary, and the number of force lines produced by a given rate of change of current must be high. Both conditions can be met by wrapping the primary and secondary coils around an iron core, as Faraday did in his early experiments. Iron increases the number of

**Table 4.1** Properties of Magnetic Materials and Magnetic Alloys (After [2]).

Material (Composition)	Initial Relative Permeability, $\mu_i/\mu_0$	Maximum Relative Permeability, $\mu_{max}/\mu_0$	Coercive Force, $H_c$ , A/m (Oe)	Residual Field, $B_r$ , Wb/m <sup>2</sup> (G)	Saturation Field, $B_s$ , Wb/m <sup>2</sup> (G)	Electrical Resistivity, $\rho \times 10^{-8} \Omega \text{ m}$	Uses
Commercial iron (0.2 imp.)	250	9,000	$\approx$ 80 (1)	0.77 (7,700)	2.15 (21,500)	10	Relays
Purified iron (0.05 imp.)	10,000	200,000	4.00 (0.05)	—	2.15 (21,500)	10	
Silicon-iron (4 Si)	1,500	7,000	20.00 (0.25)	0.5 (5,000)	1.95 (19,500)	60	Transformers
Silicon-iron (3 Si)	7,500	55,000	8.00 (0.1)	0.95 (9,500)	2.00 (20,000)	50	Transformers
Silicon-iron (3 Si)	—	116,000	4.80 (0.06)	1.22 (12,200)	2.00 (20,100)	50	Transformers
Mu metal (5 Cu, 2 Cr, 77 Ni)	20,000	100,000	4.00 (0.05)	0.23 (2,300)	0.65 (6,500)	62	Transformers
78 Permalloy (78.5 Ni)	8,000	100,000	4.00 (0.05)	0.60 (6,000)	1.08 (10,800)	16	Sensitive relays
Supermalloy (79 Ni, 5 Mo)	100,000	1,000,000	0.16 (0.002)	0.50 (5,000)	0.79 (7,900)	60	Transformers
Permendur (50 Cs)	800	5,000	160.00 (2)	1.40 (14,000)	2.45 (24,500)	7	Electromagnets
Mn-Zn ferrite	1,500	2,500	16 .00(0.2)	—	0.34 (3,400)	$20 \times 10^6$	Core material coils
Ni-Zn ferrite	2,500	5,000	8.00 (0.1)	—	0.32 (3,200)	$10^{11}$	Core material coils



**Figure 4.6** Magnetization curve of commercial iron. Permeability is given by the ratio  $B/H$ . (After [2]. From [1]. Used with permission.)

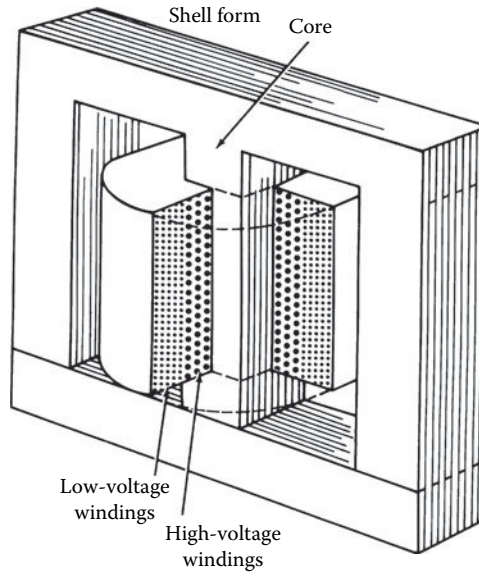


**Figure 4.7** The basic principles of electromagnetic induction.

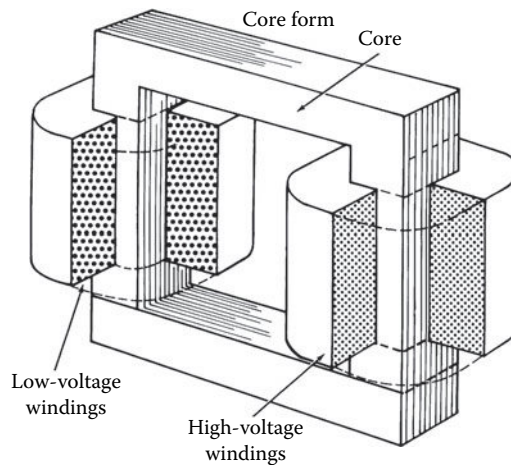
lines of force generated in the transformer by a factor of about 10,000. This property of iron is referred to as *permeability*. The iron core also contains the lines so that the primary and secondary coils can be separated spatially and still closely coupled magnetically.

With the principles of the transformer firmly established, American industrialist George Westinghouse and his associates made several key refinements that made practical transformers possible. The iron core was constructed of thin sheets of iron cut in the shape of the letter E. Coils of insulated copper wire were wound and placed over the center element of the core. Straight pieces of iron were laid across the ends of the arms to complete the magnetic circuit. This construction still is common today. [Figure 4.8](#) shows a common E-type transformer. Note how the low-voltage and high-voltage windings are stacked on top of each other. An alternative configuration, in which the low-voltage and high-voltage windings are located on separate arms of a core box, is shown in [Figure 4.9](#).

In an ideal transformer, all lines of force pass through all the turns in both coils. Because a changing magnetic field produces the same voltage in each turn of the coil, the total voltage induced in a coil is



**Figure 4.8** Physical construction of an E-shaped core transformer. The low- and high-voltage windings are stacked as shown.



**Figure 4.9** Transformer construction using a box core with physical separation between the low- and high-voltage windings.

proportional to the total number of turns. If no energy is lost in the transformer, the power available in the secondary is equal to the power fed into the primary. In other words, the product of current and voltage in the primary is equal to the product of current and voltage in the secondary. Thus, the two currents are inversely proportional to the two voltages and therefore, inversely proportional to the turns ratio between the coils. This expression of power and current in a transformer is true only for an ideal transformer. Practical limitations prevent the perfect transformer from being constructed.

The key properties of importance in transformer core design include:

- Permeability
- Saturation
- Resistivity
- Hysteresis loss

Permeability, as discussed previously, refers to the number of lines of force a material produces in response to a given magnetizing influence. Saturation identifies the point at which the ability of the core to carry a magnetic force reaches a limiting plateau. These two properties define the power-handling capability of the core element. Electrical resistivity is desirable in the core because it minimizes energy losses resulting from *eddy currents*. In contrast, hysteresis undermines the efficiency of a transformer. Because of the interactions among groups of magnetized atoms, losses are incurred as the frequency of the changing magnetic field is increased. Throughout the history of transformer development, the goal of the design engineer has been to increase permeability, saturation, and resistivity, while decreasing hysteresis losses. A variety of core materials, including silicon iron in various forms, have been used.

Transformer efficiency is defined as

$$E = \frac{P_{out}}{P_{in}} \times 100 \quad (4.17)$$

where:

- $E$  = Efficiency in percent
- $P_{out}$  = Transformer power output in watts
- $P_{in}$  = Transformer power input in watts

Losses in a transformer are the result of copper losses in the windings and core losses. The copper losses vary with the square of the current; the core losses vary with the input voltage magnitude and frequency. Because neither of these quantities depend on the power being consumed by the load, power transformers are rated by the voltamperes (VA) that flow through them.

The regulation specification of a power transformer is a measure of the transformer's ability to maintain a constant output voltage under varying loads. The primary voltage is held constant at the value required to produce the rated voltage on the secondary at full load:

$$R = \frac{V_{s0} - V_{sfl}}{V_{sfl}} \times 100 \quad (4.18)$$

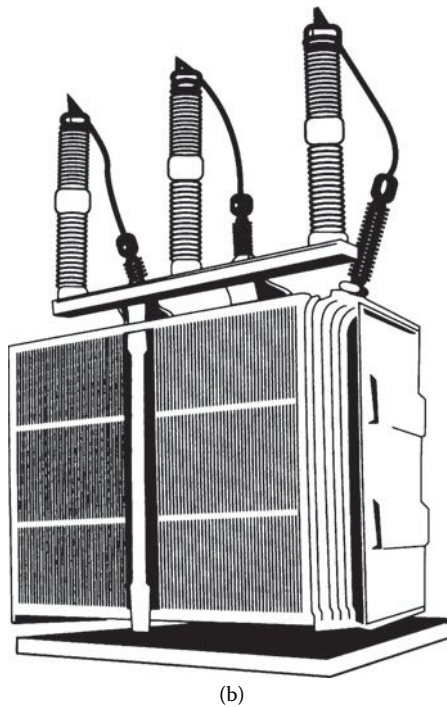
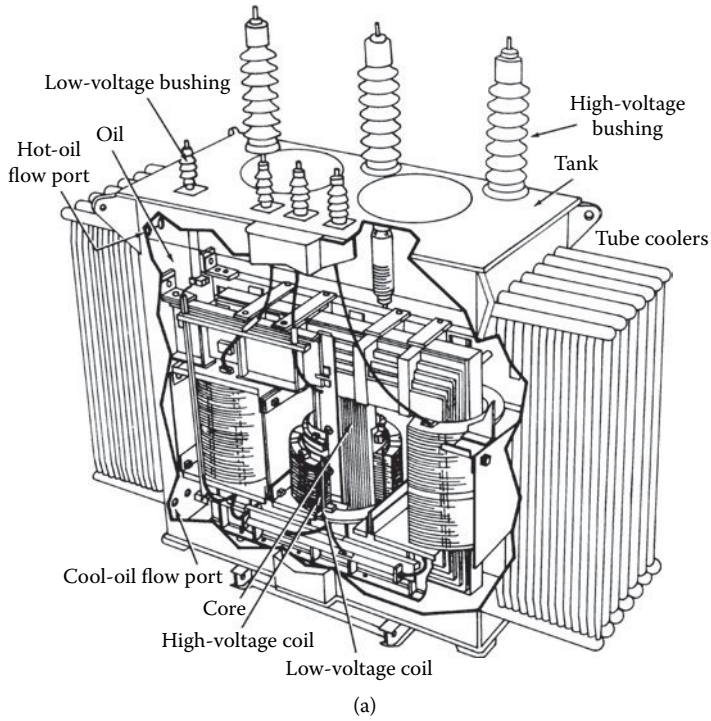
where

- $R$  = Regulation in percent
- $V_{s0}$  = Secondary voltage under no load
- $V_{sfl}$  = Secondary voltage under full load

Also bearing on transformer performance are electrical insulation and the cooling system used. These two elements are intimately related because the amount of heat that the core and conductors generate determines the longevity of the insulation; the insulation itself — whether solid, liquid, or gas — serves to carry off some portion of the heat produced. Temperatures inside a commercial transformer may reach 100°C, the boiling point of water. Under such conditions, deterioration of insulating materials can limit the useful lifetime of the device. Although oils are inexpensive and effective as insulators and coolants, some oils are flammable, making them unacceptable for units placed inside buildings. Chlorinated hydrocarbon liquids (PCBs) were used extensively from the 1930s to the late 1970s, but evidence of long-term toxic effects prompted a ban on their use. Some transformers rely on air- or nitrogen-gas-based insulators. Such devices can be installed indoors. The breakdown strength of gas sometimes is enhanced through the addition of small quantities of fluorocarbons. Other dry transformers depend on cast-resin insulation made of polymerizing liquids that harden into high-integrity solids. Progress in heat removal is largely responsible for reducing the overall size of the transformer assembly.

Modern high-power commercial transformers may operate at voltages of 750 kV or more and can handle more than 1000 kVA. The expected lifetime of a commercial power transformer ranges from 24 to 40 years. A typical three-phase oil-cooled transformer is shown in [Figure 4.10](#).





**Figure 4.10** Construction of an oil-filled three-phase power transformer used for commercial power distribution: (a) cutaway view; (b) exterior view. (Drawing b from [5]. Used with permission.)

### 4.3.1 Counter-Electromotive Force

All transformers, generators, and motors exhibit the property of inductance. This property is the result of a *counter-emf* that is produced when a magnetic field is developed around a coil of wire. Inductance presents an opposition to the change in current flow in a circuit. This opposition is evident in the diagram shown in Figure 4.11. In a purely inductive circuit (containing no resistance), the voltage will lead the current by 90°. However, because all practical circuits have resistance, the offset will vary from one circuit to the next. Figure 4.12 illustrates a circuit in which voltage leads current by 30°. The angular separation between voltage and current is referred to as the *phase angle*. The phase angle increases as the inductance of the circuit increases. Any inductive circuit exhibits the property of inductance, including electrical power-transmission and distribution lines. The henry is the unit of measurement for inductance. A circuit has a 1 H inductance if a current changing at a rate of 1 A/s produces an induced counter-emf of 1 V.

In an inductive circuit with ac applied, an opposition to current flow is created by the inductance. This opposition is known as *inductive reactance* ( $X_L$ ). The inductive reactance of a given ac circuit is determined by the inductance of the circuit and the rate of current change. Inductive reactance can be expressed as

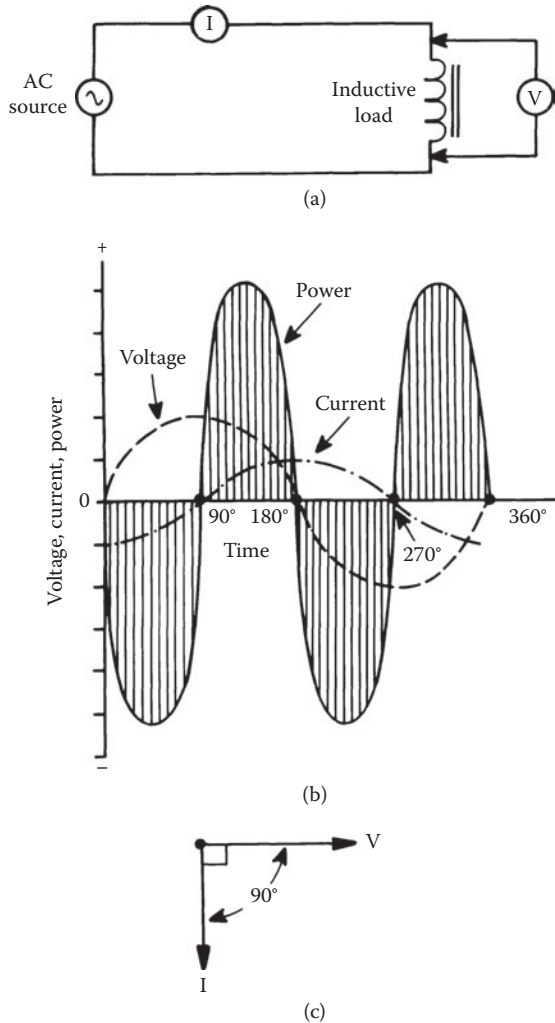
$$X_L = 2 \pi f L \tag{4.19}$$

where

- $X_L$  = inductive reactance in ohms
- $2\pi = 6.28$ , the expression for one sine wave of alternating current (0° to 360°)
- $f$  = frequency of the ac source in hertz
- $L$  = inductance of the circuit in henrys

### 4.3.2 Full Load Percent Impedance

The *full load percent impedance* (FLPI) of a transformer is an important parameter in power-supply system design. FLPI is determined by the construction of the core and physical spacing between the primary and secondary windings. Typical FLPI values range from 1 to 5%. FLPI is a measure of the ability of a transformer to maintain its rated voltage with a varying load. The lower the FLPI, the better the regulation. FLPI also determines the maximum fault current that the transformer can deliver. For example, if a 5% FLPI transformer supplying 5 A nominal at the secondary is short-circuited, the device can,



**Figure 4.11** Purely inductive circuit: (a) circuit diagram; (b) representative waveforms; (c) vector representation.

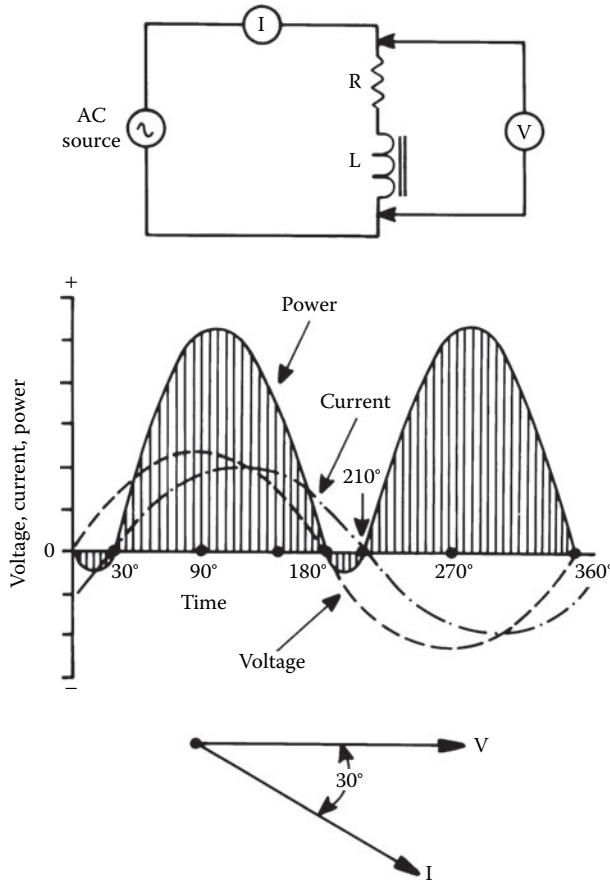


Figure 4.12 Resistive-inductive circuit: (a) circuit diagram; (b) representative waveforms; (c) vector representations.

theoretically, supply 100 A at full voltage. A similar transformer with a 10% FLPI can supply only 50 A when short-circuited. Typical short-circuit currents for a selection of small three-phase transformers are listed in Table 4.2.

### 4.3.3 Design Considerations

As touched upon previously, permeability  $\mu$  describes the ease with which magnetic flux can be produced in a given material. More flux will be produced in a material with a high permeability than in one with a low permeability, given the same amount of current and the same number of turns in the coil. The ratio of a material's permeability to the permeability of free space, called *relative permeability*, is often used [6]. The actual permeability, which has units of webers per ampere-turn-meter, is found by multiplying the permeability of free space by the relative permeability.

The overall ability of a core to carry flux also depends on its size and shape, and its cross-sectional area. This is described by *permeance*. The basic relationship of permeance to permeability in a core is defined by

$$P = \frac{\mu A}{l} = \frac{l}{R} \quad \text{or} \quad R = \frac{l}{\mu A} \tag{4.20}$$

**Table 4.2** Full Load Percent Impedance Short-Circuit Currents for a Selection of Three-Phase Transformers

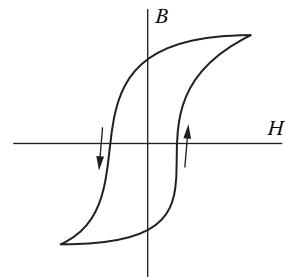
DC Amps (kVa/kV)	Full Load Percent Impedance	Symmetrical Short-Circuit Current
1 A	1	57.7
1 A	2	28.8
1 A	3	19.3
1 A	4	14.4
1 A	5	11.5
2 A	1	115.5
2 A	2	57.7
2 A	3	38.5
2 A	4	28.8
2 A	5	23.1
3 A	1	173.2
3 A	2	86.6
3 A	3	57.7
3 A	4	43.3
3 A	5	34.6
4 A	1	230.9
4 A	2	115.5
4 A	3	77.0
4 A	4	57.7
4 A	5	46.2
5 A	1	288.6
5 A	2	144.3
5 A	3	96.2
5 A	4	72.2
5 A	5	57.7

where

- $P$  = Permeance
- $\mu$  = Permeability of the material
- $A$  = The cross-sectional area of the core
- $l$  = The mean length of the flux path in the core

This equation assumes uniform flux distribution in the core and constant permeability inside the core. It does not take into account the variations in the length of the flux path from the inside of the core to the outside. The reciprocal of permeance is *reluctance*.

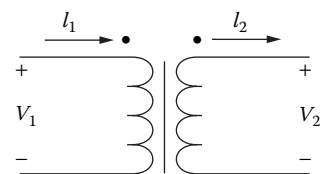
Figure 4.13 shows the magnetization curve for a typical ferromagnetic material. Note that the curve follows two different paths, depending on whether the magnetizing force  $H$  is increasing or decreasing. This is called a *hysteresis curve*. It is caused by the fact that the magnetic particles in the core need to be rotated and realigned each time the polarity of the magnetizing force changes. This is why the magnetic force must be reversed to reduce the flux density to zero.



**Figure 4.13** A typical magnetization curve. (From [6]. Used with permission.)

As the magnetizing force  $H$  increases, the flux density increases up to a point, and then the curve flattens out. In this flattened region, only a small increase in the flux density can be achieved, as illustrated in the figure. The core is said to be *saturated*. The flattening of the curve indicates that the permeability has decreased from the value it had when there was only a small amount of flux passing through the core.

To eliminate ambiguity in the voltage and current polarity at the input and output of the transformer symbol, the *dot convention* is commonly used. In circuit diagrams, a small dot is placed near one end of each coil, as shown in Figure 4.14. The dot indicates a



**Figure 4.14** Dotted schematic symbol for a transformer. (From [6]. Used with permission.)

rise in voltage from the unmarked to the marked terminal on each coil. Under this convention, current into the dot on the primary side is labeled as having positive polarity, and current out of the dotted terminal on the other side is assigned positive polarity. This means that the power flow must be into the transformer on one side and out of the transformer on the other side.

### 4.3.4 The Ideal Transformer

Although no transformer is ideal in its characteristics, transformers approach their ideal characteristics in the operating range for which they were designed. The ideal transformer has no coil resistance and no core losses, so that it has no power loss [6]. It also has no leakage inductance, because the permeability of the core is infinite, and the core material is able to carry an infinite amount of flux without saturating. Therefore, the mutual inductance is also infinite. The capacitance in an ideal transformer is negligible. The equations for an ideal transformer are given as

$$v_1 i_1 = v_2 i_2 \tag{4.21}$$

$$\frac{v_1}{v_2} = \frac{N_1}{N_2} \tag{4.22}$$

$$\frac{i_1}{i_2} = \frac{N_2}{N_1} \tag{4.23}$$

$$\frac{Z_1}{Z_2} = \left(\frac{N_1}{N_2}\right)^2 \tag{4.24}$$

where

- $v_1$  = Voltage in the primary
- $v_2$  = Voltage in the secondary
- $i_1$  = Current in the primary
- $i_2$  = Current in the secondary
- $N_1$  = Turns in the primary
- $N_2$  = Turns in the secondary
- $Z_1$  = Impedance of the primary
- $Z_2$  = Impedance of the secondary

Equation 4.8 describes the effect of the transformer on an impedance on the secondary side (multiplied by the square of the turns ratio). The magnitude of the impedance as seen on the secondary side is referred to as the *reflected impedance*.

Equivalent circuits are often used to model the performance of transformers with greater accuracy. Although equivalent circuits are not exact replicas of real transformers, they are close enough to realize accurate results for most situations. The complete transformer equivalent circuit is shown in Figure 4.15.

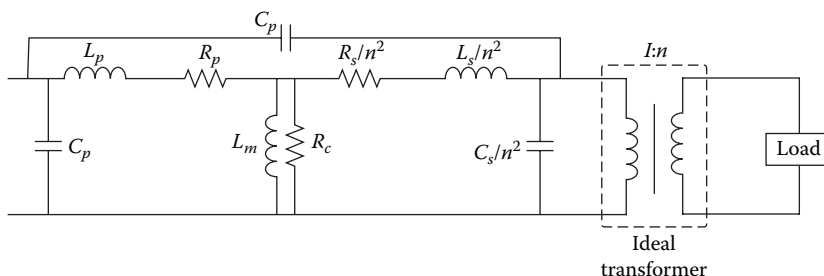
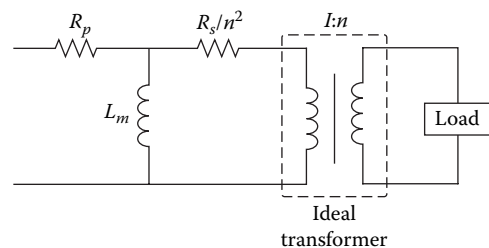


Figure 4.15 Transformer equivalent circuit. (From [6]. Used with permission.)

The leakage inductance of both coils has been modeled by an inductor in series with the load, because the current in the coils also produces the leakage flux. These inductances are labeled  $L_p$  and  $L_s$ , respectively. Notice that the leakage inductance for the secondary side has been divided by the turns ratio  $n^2$  because it was reflected to the primary side. Resistors  $R_p$  and  $R_s$  are placed in series with the load to represent the resistance of the conductors used to wind the coils. Again, the secondary resistance is divided by the square of the turns ratio because it was reflected.

The mutual inductance is represented by shunt inductor  $L_m$ , because the magnetizing current is not coupled to the load. Resistor  $R_c$  is also placed in shunt to represent the core loss resulting from hysteresis and eddy currents in the core. The stray capacitances between turns of the coils are represented by a capacitor connected across each pair of terminals. This capacitance is larger for coils with more turns. Although the capacitance is actually distributed, it is lumped for the equivalent circuit, in order to simplify the analysis. The capacitance from one coil to the other is represented by another capacitor placed in parallel with the leakage inductance and resistance.

The transfer function of the complete equivalent circuit is quite complex. For this reason, the equivalent circuit is often broken up into several equivalent circuits, each of which is valid only for a certain set of operating conditions. In the low-frequency range, the transformer acts like a highpass filter. (See Figure 4.16.) Above the *corner frequency*, the output voltage is nearly equal to the input voltage. Below the corner frequency, the output voltage is substantially smaller than the input voltage because of the presence of shunt inductor  $L_m$ . The distributed capacitances and leakage inductances can be largely neglected.



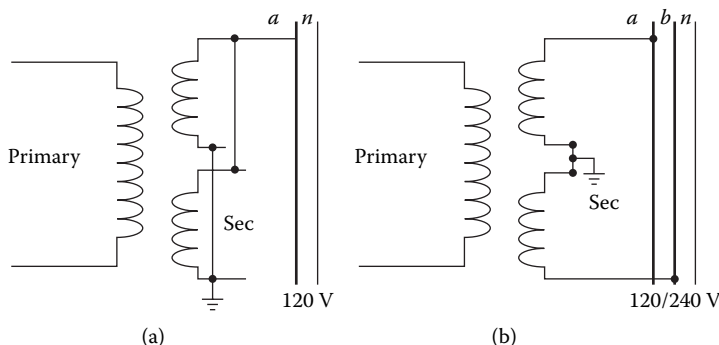
**Figure 4.16** Transformer equivalent circuit for low-frequencies. (From [6]. Used with permission.)

### 4.3.5 Application Considerations

Transformers are the most common pieces of equipment found in utility substations and distribution systems. Different types of transformers are used for varied purposes, from voltage level changes to phase angle regulation [7]. Because the primary circuits of distribution systems are designed for high voltages (in order to increase their load-carrying capability), the voltage must be stepped down at the consumer service entrance.

Transformers can be classified as *distribution transformers* and *power transformers*. The former type normally steps down voltages from primary voltage levels, such as 2,400, 4,160, or 13,800 V, to 120 or 240 V. These devices are almost always located outdoors where they are hung from crossarms, mounted on poles directly, or placed on platforms or in underground vaults. Power transformers are larger in size than distribution transformers and usually have auxiliary means for cooling. These transformers are typically installed at distribution substations for stepping down voltages from the subtransmission levels of 34.5 and 69 kV to primary distribution levels of up to 13.8 kV.

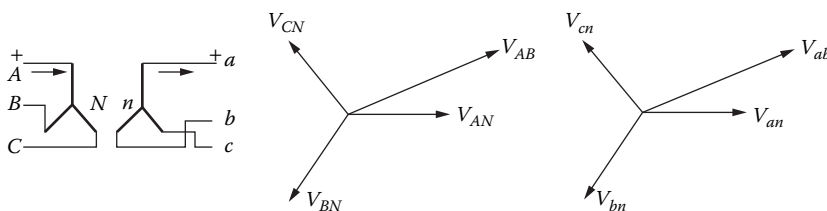
Single-phase distribution transformers typically have one high-voltage primary winding and two low-voltage secondary windings, which are rated at a nominal 120 V. The secondary coils may be connected in parallel to supply a two-wire 120 V circuit, shown in Figure 4.17a, or in series to supply a three-wire 120/240 V single circuit, shown in Figure 4.17b. As seen in the figures, one leg of the 120 V two-wire system and the middle leg of the 120/240 V three-wire system are grounded to limit the voltage to ground on the secondary side. In general, the 120/240 V three-wire connection is preferred because it has twice the load capacity of the 120 V system with only a 1.5 times increase in conductor size. Each 120 V winding has one half the total kilovoltampere rating of the transformer. The loads on the secondary side of the transformers are kept as balanced as possible, such that maximum transformer capacity can be utilized, and the neutral current kept to a minimum.



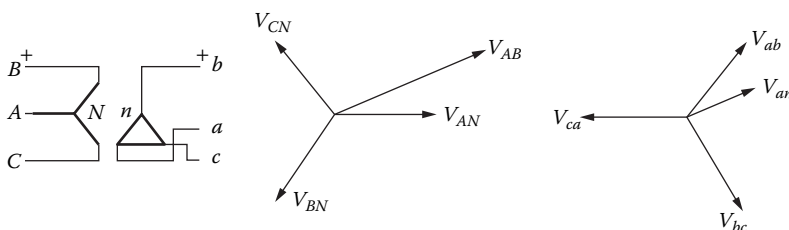
**Figure 4.17** Connections for a single-phase distribution transformer: (a) parallel connection, (b) series connection. (From [7]. Used with permission.)

A three-phase transformer bank can be easily created by using three single-phase transformers. The two sides of these three transformers can be either connected in a *wye* or a *delta* configuration, thus allowing four possible types of connections. These are

- **Wye-wye.** With the wye-wye (Y-Y) connection, the secondary side is in phase with the primary circuit, and the ratio of primary to secondary voltage is the same as the ratio of turns in each of the phases. A possible connection is shown in Figure 4.18. Power distribution circuits supplied from a wye-wye bank often create series disturbances in communication circuits (e.g., telephone interference) in their immediate vicinity. One of the advantages of this connection is that when a system is changed from a delta to a four-wire wye to increase system capacity, existing transformers can be used.
- **Wye-delta.** In the Y- $\Delta$  connection, there is a  $30^\circ$  phase angle shift between the primary and secondary sides. The phase angle difference can be made either lagging or leading, depending on the external connections of the transformer bank. The case with the primary side lagging is shown in Figure 4.19, and the case with the primary side leading is shown in Figure 4.20. The transformation ratio is  $\sqrt{3}$  times the ratio of turns in each of the phases.



**Figure 4.18** Y-Y transformer with  $0^\circ$  phase shift between the primary and the secondary sides. (From [7]. Used with permission.)



**Figure 4.19** Y- $\Delta$  transformer with the primary side lagging the secondary side by  $30^\circ$ . (From [7]. Used with permission.)



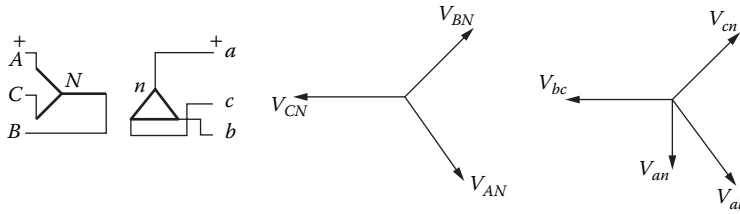


Figure 4.20 Y-Δ transformer with the primary side leading the secondary side by 30°. (From [7]. Used with permission.)

- **Delta-wye.** With the Δ-Y connection, the neutral of the secondary wye can be grounded and single-phase loads connected across the phase and the neutral conductor. Three-phase loads are connected across the phases. The phasor relationship between the primary and the secondary sides is shown in Figure 4.21. The transformation ratio is  $1/\sqrt{3}$  times the ratio of turns in each of the phases.
- **Delta-delta.** The Δ-Δ connection does not cause a phase shift between the primary and the secondary sides. The phasor relationship of this transformer is shown in Figure 4.22. The transformation ratio is equal to the ratio of the turns in each of the phases. There is no problem from third-harmonic overvoltage or telephone interference because such disturbances get trapped in the delta and do not pass into the lines.

Although these four configurations are the most common ones used, other arrangements are possible, including:

- **Open-delta.** An advantage of the Δ-Δ connection is that if one of the single-phase transformers becomes damaged or is removed for maintenance, the remaining two can be operated in a so-called *open-delta* connection. Because the currents in each of the two remaining transformers are the same as the line current, each transformer carries  $\sqrt{3}$  times the current it was carrying in the closed-delta connection. The open-delta bank continues to deliver three-phase currents and voltages in their correct phase relationship. To keep the transformers from being overloaded, however, it is necessary to reduce the line currents by approximately  $1/\sqrt{3}$ .

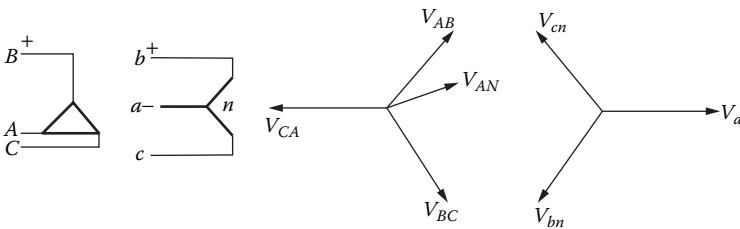


Figure 4.21 Δ-Y transformer with the primary side leading the secondary side by 30°. (From [7]. Used with permission.)

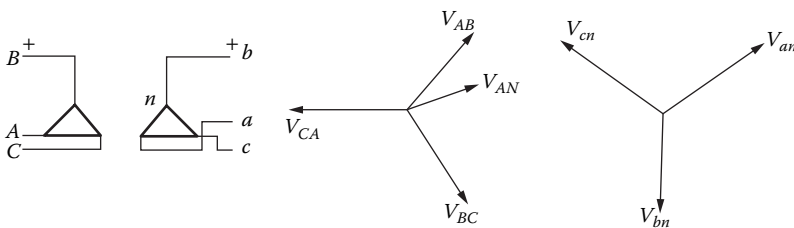
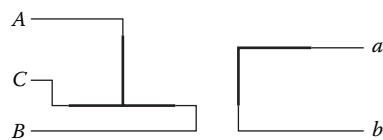


Figure 4.22 Δ-Δ transformer with 0° phase shift between the primary and the secondary sides. (From [7]. Used with permission.)



- Scott or T-connection.** The Scott or T-connection is used when a two-phase (or a transformed three-phase) supply is needed from a three-phase system. In general, the T-connection is used for deriving a three-phase transformation, and the Scott connection is mainly used for obtaining a two-phase output. The two connections are similar in basic design. Either connection requires two specially wound single-phase transformers. The main transformer has a 50% tap on the primary winding, whereas the other transformer, called the *teaser transformer*, has an 86.6% tap. The main transformer is connected between two primary lines, whereas the teaser transformer is connected from the center tap of the main transformer to the third primary line. The secondary sides of the transformers provide two-phase service. A T-connection is shown in Figure 4.23.



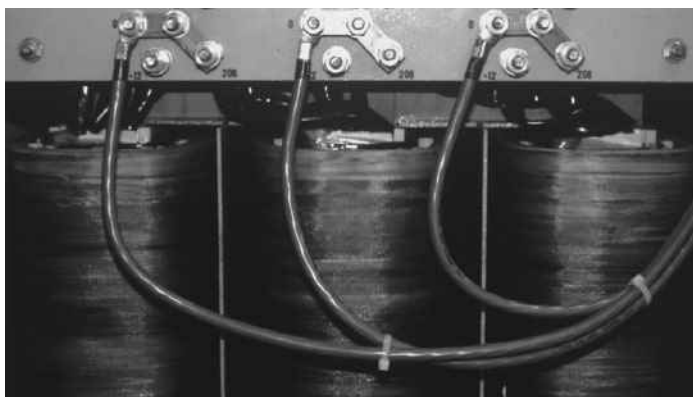
**Figure 4.23** The T-connection for a three-phase to two-phase transformation. (From [7]. Used with permission.)

The secondary sides of the transformers provide two-phase service. A T-connection is shown in Figure 4.23.

## 4.4 Transformer Failure Modes

The failure of a power transformer is almost always a catastrophic event that will cause the system to fail. The two primary enemies of power transformers are transient overvoltages and heat. Power input to a transformer is not all delivered to the secondary load. Some is expended as copper losses in the primary and secondary windings. These  $I^2R$  losses are practically independent of voltage; the controlling factor is current flow. To keep the losses as small as possible, the coils of a power transformer are wound with wire of the largest cross section that space will permit. A medium-power, three-phase power transformer is shown in Figure 4.24.

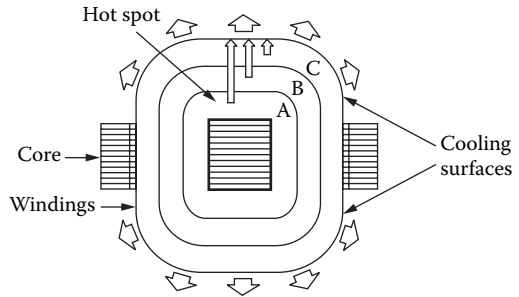
A practical transformer also will experience core-related losses, also known as *iron losses*. Repeated magnetizing and demagnetizing of the core (which occurs naturally in an ac waveform) results in power loss because of the repeated realignment of the magnetic domains. This factor (hysteresis loss) is proportional to frequency and flux density. Silicon steel alloy is used for the magnetic circuit to minimize hysteresis loss. The changing magnetic flux also induces circulating currents (eddy currents) in the core material. Eddy current loss is proportional to the square of the frequency and the square of the flux density. To minimize eddy currents, the core is constructed of laminations or layers of steel that are clamped or bonded together to form a single magnetic mass.



**Figure 4.24** A medium-power, three-phase transformer.

### 4.4.1 Thermal Considerations

Temperature rise inside a transformer is the result of power losses in the windings and the core. The insulation within and between the windings tends to blanket these heat sources and prevents efficient dissipation of the waste energy, as illustrated in Figure 4.25. Each successive layer of windings (shown as A, B, and C in the figure) acts to prevent heat transfer from the hot core to the local environment (air).



**Figure 4.25** The dynamic forces of heat generation in a power transformer.

The hot spot shown in the figure can be dangerously high even though the outside transformer case and winding are relatively cool to the touch. Temperature rise is the primary limiting factor in determining the power-handling capability of a transformer. To ensure reliable operation, a large margin of safety must be designed into a transformer. Design criteria include winding wire size, insulation material, and core size.

#### 4.4.1.1 Life Expectancy and Temperature

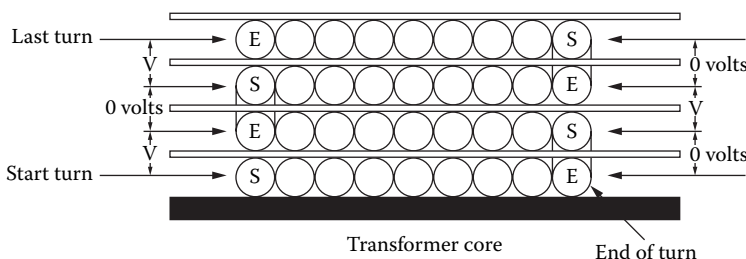
The nameplate kVA rating of a transformer represents the kVA that will result in the rated average winding temperature rise when the unit is operated at 100% of rated kVA under normal service conditions [8]. When operating under these conditions, the result should be a normal life expectancy for the transformer.

A general rule of thumb says that a 30-year life can be expected for a transformer with a 220°C insulating system that has a winding hot-spot temperature allowance of 30°C. Operating such a transformer at rated kVA on a continuous basis with a 30°C, 24-hr average ambient (40°C maximum ambient) should equate to a normal useful life.

It should be recognized that the life expectancy of transformers operating at varying temperatures is not accurately known. Fluctuating load conditions and changes in ambient temperatures make it difficult, if not impossible, to arrive at such definitive information. However, if a transformer is operated under normal conditions, it could easily last longer. A 40-year life span is not unusual, and some transformers have exceeded that.

### 4.4.2 Voltage Considerations

Transformer failures resulting from transient overvoltages typically occur between layers of windings within a transformer. (See Figure 4.26.) At the end of each layer, where the wire rises from one layer to the next, zero potential voltage exists. However, as the windings move toward the opposite end of the coil in a typical layer-wound device, a potential difference of up to twice the voltage across one complete layer exists. The greatest potential difference, therefore, is found at the far opposite end of the layers.

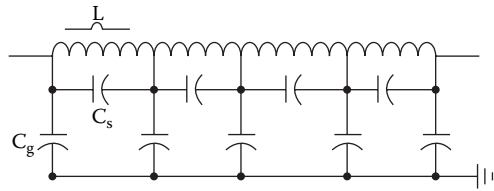


**Figure 4.26** Voltage distribution between the layers of a typical layer-wound power transformer.

This voltage distribution applies to continuous 60 Hz signals. When the transformer is first switched on or when a transient overvoltage is impressed upon the device, the voltage distribution from one hot layer to the next can increase dramatically, raising the possibility of arc-over. This effect is caused by the inductive nature of the transformer windings and the inherent distributed capacitance of the coil. Insulation breakdown can result from one or more of the following:

- Puncture through the insulating material of the device
- Tracking across the surface of the windings
- Flashing through the air

Any of these modes can result in catastrophic failure. Figure 4.27 illustrates the mechanisms involved. A transformer winding can be modeled as a series of inductances and shunt capacitances. The interturn and turn-to-ground capacitances are shown by  $C_s$  and  $C_g$ , respectively. During normal operation, the applied voltage is distributed evenly across the full winding. However, if a steep front wave is impressed upon the device, the voltage distribution radically changes. For the voltage wave to start distributing itself along the winding, the line-to-ground capacitance ( $C_g$ ) must be charged. This charging is dependent upon the transformer winding-to-ground capacitance and the impedance of the supply line.



**Figure 4.27** Capacitive distribution along the windings of a power transformer.

### 4.4.3 Mechanical Considerations

Current flow through the windings of a transformer applies stress to the coils. The individual turns in any one coil tend to be crushed together when current flows through them. There also may be large repulsion forces between the primary and secondary windings. These mechanical forces are proportional to the square of the instantaneous current; they are, therefore, vibratory in nature under normal operating conditions. These forces, if not controlled, can lead to failure of the transformer through insulation breakdown. Vibration over a sufficient period of time can wear the insulation off adjacent conductors and create a short circuit. To prevent this failure mode, power transformers routinely are coated or dipped into an insulating varnish to solidify the windings and the core into one element.

#### 4.4.3.1 Dry-Type and Liquid-Filled Transformers

The advantages and disadvantages of dry-type transformers vs. liquid-filled units depend upon the application [9]. Dry-type transformers can usually be located closer to the load, resulting in cost savings because of shorter cable runs and lower electrical losses. A liquid-filled transformer, on the other hand, may require special construction features for the room in which it will be placed because of fire-safety considerations. This may dictate a location some distance from the load. In addition, periodic testing must be conducted on the fluid to determine its dielectric strength, water content, dissolved gases, and other parameters.

In some applications, there is no option to the use of liquid-filled transformers; dry-types are limited in size and voltage handling capability. Liquid-filled types are available in almost limitless kVA and voltage ratings. Also, if requirements call for a transformer to be located outdoors, it may be less expensive to purchase a liquid-filled unit. With oil as the liquid, the cost would be lower than for a dry-type of equivalent rating; with low-firepoint fluids, the cost would probably be comparable to a dry-type.

For liquid-filled transformers, the main cooling/insulating mediums used today are mineral oil, high-molecular-weight hydrocarbon, and silicone fluid. If a leak occurs in the transformer tank, fire safety becomes an important issue. Because of hazards associated with tank rupture and the possible ignition of the dielectric, a thorough analysis covering fire safety and the possible effects on the environment should be carried out well in advance of device installation.

Some materials are covered under the Federal Resource Conservation and Recovery Act and the Clean Water Act, including requirements for

- Special handling
- Spill reporting
- Disposal procedures
- Record-keeping

These considerations can have an effect on installation costs, long-term operating expenses, and maintenance procedures.

#### 4.4.3.2 Insulation Materials

Liquid-filled transformers use an insulation system of kraft or aramid paper, pressboard or aramid spacers, and a fluid that serves as both an insulating and cooling medium for the transformer [9]. Paper is commonly used for insulation between layers of winding material. It typically has an diamond-patterned adhesive backing that, when cured, solidly contains the winding. Spacers serve as a form (which can be rectangular or cylindrical in shape) for the windings as well as a spacer between layers of the windings. The spacing is necessary to allow the insulating fluid to flow through and cool the windings and the core. Spacers are also used to insulate the windings from the core as well as to support the leads on their path to the bushings.

Any moisture that is present in the finished core and winding assembly is purged by vacuum and oven drying processes. After removal from the oven and while still hot, all connections are tightened and the entire assembly is immersed into its liquid-filled tank. This ensures that moisture will not again penetrate into the windings and also allows the insulation to absorb the maximum amount of dielectric fluid.

The particular type of insulation used is rarely specified by the customer for other than large utility substation transformers or for unusual applications. More often, it is the transformer manufacturer's or rebuilder's choice based upon the operating conditions the transformer must meet.

#### 4.4.3.3 Insulating Liquids

Dielectric liquids of various types are used as an insulating medium as well as a means of cooling liquid-filled transformers [9]. Common insulating liquids include the following:

- **Mineral oil.** A mineral oil-filled transformer is generally the smallest, lightest, and most economical transformer available. Mineral oil has excellent properties for use in transformers, but it has the inherent weakness of being flammable. Its use, therefore, is restricted to outdoor installations or when the transformer is installed within a vault if used indoors.
- **Silicone.** A wide variety of synthetic polymer chemicals are referred to by the generic term *silicone*. Silicone transformer liquids are actually known chemically as *polydimethylsiloxane* (PDMS). PDMS is a water-clear, odorless, chemically stable, nontoxic liquid.
- **High-molecular-weight hydrocarbon (HMWH).** HMWH is another high-firepoint dielectric that is widely used as a transformer liquid. It has similar values for dielectric strength and dielectric constant, power factor, and thermal conductivity as mineral oil.

Fire properties of dielectric fluids are typically classified by the following characteristics:

- *Flash point:* The temperature at which vapors from a liquid surface will ignite in the presence of a flame.
- *Fire point:* The temperature at the surface of a liquid that will sustain a fire.
- *Flame spread:* A series of consecutive ignitions.
- *Ease of ignition:* How readily the liquid will generate and maintain a flammable fuel/vapor mixture at the surface.
- *Heat release rate:* The product of vaporization rate and the heat of combustion of the fluid. The higher this rate in a large-scale fire, the higher the degree of fire hazard.

Selection of the dielectric liquid depends on the transformer application. Normally, the choice is mineral oil if the device is to be located outdoors. The National Electrical Code (NEC) does, however, specify certain limitations regarding the use of oil-filled transformers in particular outdoor locations. The selection of less-flammable liquids (PDMS and HMWH) often depends upon personal preference, the liquid used in other transformers on the site, or the transformer manufacturer's recommendation.

#### 4.4.3.4 Cooling

In cooling a liquid-filled transformer, the insulating fluid flows in the transformer through ducts and around the coil ends within a tank that contains the core and coils [9]. Removal of the heat from the fluid takes place in external tubes. These radiators consist of headers extending from the bottom and top of the transformer tank and rows of tubes connected between the two headers. When operating within its *self-cooled* (OA) rating, natural convection caused by temperature differences within the tank carries the oil up through the windings, down through the cooling tubes, and back into the tank. The transformer fluid, acting as a heat-transfer medium, picks up the heat from the core and coils and dissipates it to the air via the tubes.

Auxiliary cooling fans can be provided if the transformer is to be operated above its self-cooled ratings. This is advisable when the transformer is to operate under occasional heavy overloads or high ambient temperatures, or to accommodate new loads beyond its rating. Liquid-filled transformers, because of their double heat-transfer requirement (core/coil-to-liquid and liquid-to-air), have a lower forced air (FA) rating than dry-types. In liquid-filled types, the forced air rating of transformers up to 2500 kVA is raised to 115% of its self-cooled kVA rating, and those of larger units to 125% of their self-cooled VA rating.

Cooling fans can be controlled manually or automatically. Fans can be cycled on automatically based on the top oil temperature, winding temperature, or ambient temperature. Alarm contacts and remote indication are also available options.

## 4.5 References

1. Parker, M. R., and W. E. Webb: "Magnetic Materials for Inductive Processes," in *The Electronics Handbook*, 2nd ed, J. C. Whitaker (Ed.), CRC Press, Boca Raton, FL, 2005.
2. Plonus, M. A.: *Applied Electromagnetics*, McGraw-Hill, New York, NY, 1978.
3. Irwin, J. D.: *Basic Engineering Circuit Analysis*, 5th ed., Macmillan, New York, 1995.
4. Cheng, D. A.: *Fundamentals of Engineering Electromagnetics*, Addison-Wesley, New York, 1993.
5. Gross, C., "Fault Analysis in Power Systems," in *The Electrical Engineering Handbook*, R. C. Dorf (Ed.), p. 1252, CRC Press, Boca Raton, FL, 1993.
6. Ula, S., "Transformers," in *The Electronics Handbook*, Jerry C. Whitaker (Ed.), p. 927, CRC Press, Boca Raton, FL, 1996.
7. Chowdhury, B., "Power Distribution and Control," in *The Electronics Handbook*, J.C. Whitaker (Ed.), p. 1003, CRC Press, Boca Raton, FL, 1996.
8. Berutti, A., "Specifying Dry-Type Transformers," in *Practical Guide to Applying, Installing, and Maintaining Transformers*, Robert Morgan (Ed.), PRIMEDIA Intertec, Overland Park, KS, p. 66–70, 1994.
9. Berutti, A., "Specifying Liquid-Filled Transformers," in *Practical Guide to Applying, Installing, and Maintaining Transformers*, Robert Morgan (Ed.), PRIMEDIA Intertec, Overland Park, KS, p. 56–58, 1994.

## 4.6 Bibliography

Fink, D., and D. Christiansen (Eds.), *Electronics Engineers' Handbook*, 3rd ed., McGraw-Hill, New York, 1989.

- Jordan, Edward C. (Ed.), *Reference Data for Engineers: Radio, Electronics, Computer, and Communications*, 7<sup>th</sup> ed., Howard W. Sams Company, Indianapolis, IN, 1985.
- Lawrie, R., *Electrical Systems for Computer Installations*, McGraw-Hill, New York, 1988.
- Lowdon, Eric, *Practical Transformer Design Handbook*, Howard W. Sams Company, Indianapolis, IN, 1980.
- Meeldijk, Victor, "Why Do Components Fail?" *Electronic Servicing & Technology*, Intertec Publishing, Overland Park, KS, November 1986.
- Sankaran, C., "Transformers," in *The Electrical Engineering Handbook*, R. C. Dorf (Ed.), p. 33, CRC Press, Boca Raton, FL, 1993.

# 5

## Capacitors

---

### 5.1 Introduction

---

A capacitor consists, basically, of two conductors separated by a dielectric. The operation of a capacitor in a circuit is dependent upon its ability to charge and discharge. When a capacitor charges, an excess of electrons is accumulated on one plate, and a deficiency of electrons is created on the other plate. Capacitance is determined by the size of the conductive material (the plates) and their separation (determined by the type and thickness of the dielectric material). Capacitance is directly proportional to plate size and inversely proportional to the distance between the plates. The unit of capacitance is the *farad* (F). A capacitance of 1 F results when a potential of 1 V causes an electric charge of 1 coulomb to accumulate on a capacitor.

### 5.2 Basic Principles

---

The value of a parallel-plate capacitor can be found from

$$C = \frac{x\epsilon [(N-1)A]}{d} \times 10^{-13} \quad (5.1)$$

where

- $C$  = Capacitance (F)
- $\epsilon$  = Dielectric constant of the insulation
- $d$  = Spacing between the plates
- $N$  = Number of plates
- $A$  = Area of the plates
- $x = 0.0885$  when  $A$  and  $d$  are in centimeters

The work necessary to transport a unit charge from one plate to another is

$$e = k g \quad (5.2)$$

where

- $e$  = Volts expressing energy per unit charge
- $k$  = Proportionality factor between the work necessary to carry a unit charge between the two plates and the charge already transported
- $g$  = Coulombs of charge already transported

The latter quantity ( $k$ ) is equal to  $1/C$ , where  $C$  is the capacitance in F.  
The value of a capacitor can now be calculated from

$$C = \frac{q}{e} \quad (5.3)$$

where  $q$  = charge (C) and  $e$  is found from Equation 5.2.

The energy stored in a capacitor is

$$W = \frac{CV^2}{2} \tag{5.4}$$

where

- $W$  = Energy (J)
- $C$  = Capacitance (F)
- $V$  = Applied voltage (V)

If a direct current is applied to a capacitor, the device will charge to the value of the applied voltage. After the capacitor is fully charged, it will block the flow of direct current. However, if an ac voltage is applied, the changing value of current will cause the device to alternately charge and discharge. In a purely capacitive circuit, the situation shown in Figure 5.1 will exist. The greatest amount of current will flow when the voltage changes most rapidly; that point occurs at the 0 and 180° positions in the sine wave where the polarity reverses. At these positions, maximum current is developed in the circuit, as shown. It is evident by studying the waveform that, in a purely capacitive circuit, voltage will lag current by 90°. Because all practical circuits contain some resistance, a lag of 0 to 90° may be experienced in practice. Figure 5.2 illustrates a case in which voltage lags current by 30°.

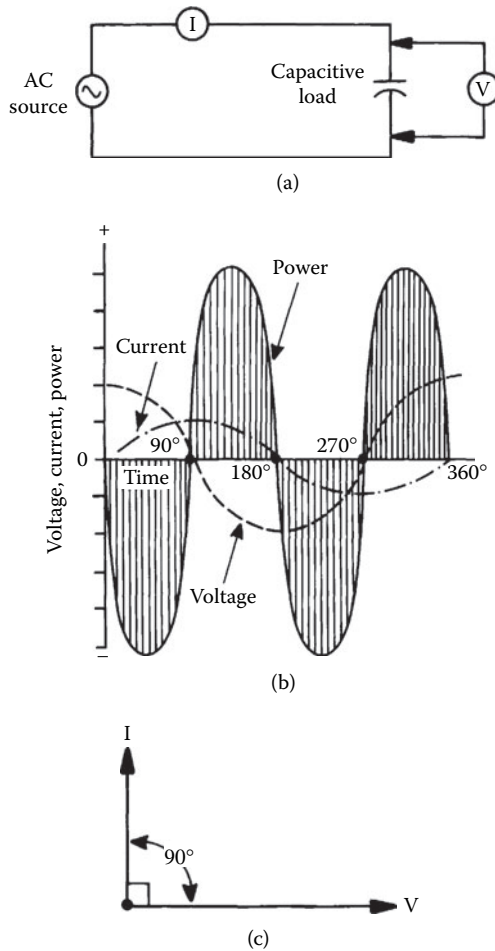
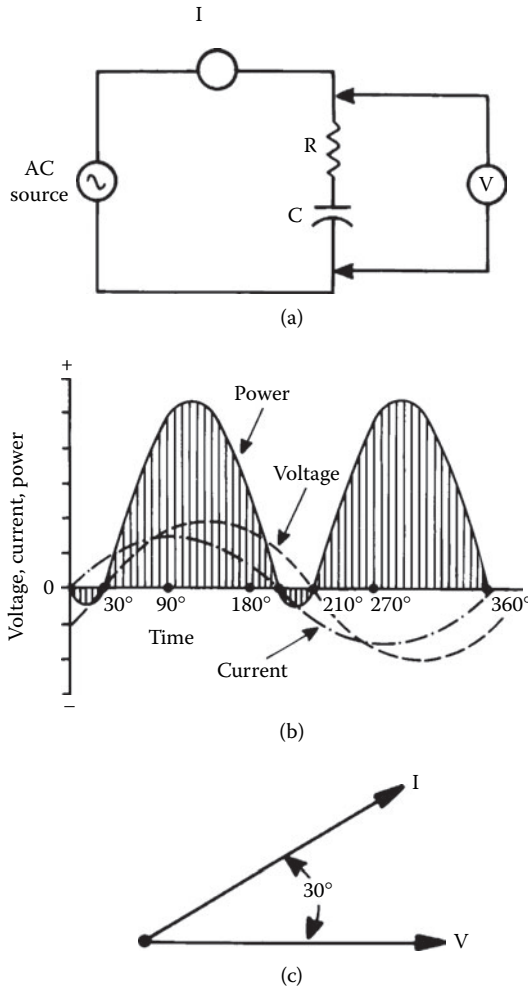


Figure 5.1 A purely capacitive circuit: (a) circuit diagram; (b) representative waveforms; (c) vector representation.





**Figure 5.2** A resistive-capacitive circuit: (a) circuit diagram; (b) representative waveforms; (c) vector representation.

Because of the electrostatic field developed around a capacitor, an opposition to the flow of alternating current exists. This opposition is known as *capacitive reactance*, defined as

$$X_c = \frac{1}{2\pi fC} \tag{5.5}$$

where

- $X_c$  = Capacitive reactance ( $\Omega$ )
- $2\pi R$  = The mathematical expression of one sine wave
- $f$  = Frequency (Hz)
- $C$  = Capacitance (F)

The dielectric used for a given capacitor varies, depending upon the application. Common dielectrics include air, gas, mica, glass, and ceramic. Each has a different *dielectric constant*, temperature range, and thickness.

The dielectric constant of a material determines the electrostatic energy that may be stored in that material per unit volume for a given voltage. The value of the dielectric constant expresses the ratio of a capacitor whose dielectric is a vacuum to one using a given dielectric material. The dielectric constant of

**Table 5.1** Comparison of Capacitor Dielectric Constants (After [1].)

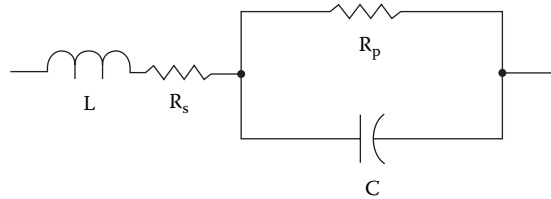
Dielectric	K (Dielectric Constant)
Air or vacuum	1.0
Paper	2.0 – 6.0
Plastic	2.1 – 6.0
Mineral oil	2.2 – 2.3
Silicone oil	2.7 – 2.8
Quartz	3.8 – 4.4
Glass	4.8 – 8.0
Porcelain	5.1 – 5.9
Mica	5.4 – 8.7
Aluminum oxide	8.4
Tantalum pentoxide	26.0
Ceramic	12.0 – 400,000.0

air is 1, the reference unit employed for characterizing this parameter. As the dielectric constant is increased or decreased, the capacitance will increase or decrease, respectively. Table 5.1 lists the dielectric constants of various common materials.

The dielectric constant of most materials is affected by both temperature and frequency, except for quartz, Styrofoam, and Teflon, whose dielectric constants remain essentially constant.

In addition to capacitance, a practical capacitor has inductance and resistance components, as shown in Figure 5.3. The stray components are identified as follows:

- $R_s$  = Series resistance of wire leads, contact terminations, and electrodes
- $R_p$  = Shunt resistance resulting from the resistivity of the dielectric and case material, and dielectric losses
- $L$  = Stray inductance resulting from the leads and the electrodes



**Figure 5.3** The equivalent circuit of a capacitor.

The *equivalent series resistance* (ESR) of a capacitor is the ac resistance of the device, reflecting both the series resistance ( $R_s$ ) and the parallel resistance ( $R_p$ ) at a given frequency. This parameter permits the loss resulting from the foregoing elements to be expressed as a loss in a single resistor in the equivalent circuit.

The *power factor* (PF) of a capacitor defines the electrical losses in the device operating under an ac voltage. In an ideal device, the current will lead the applied voltage by 90°. A practical capacitor, because of its dielectric, electrode, and contact termination losses, exhibits a phase angle of less than 90°. The power factor of a capacitor is defined as the ratio of the effective series resistance to the impedance of the capacitor. PF usually is expressed as a percentage.

The *quality factor* (Q) of a capacitor is the ratio of the capacitor reactance to the resistance of the device at a specified frequency. The Q is determined by the equations

$$Q = \frac{1}{2\pi fCR} \tag{5.6}$$

$$Q = \frac{1}{PF} \tag{5.7}$$

where

- Q = Quality factor
- f = Frequency (Hz)
- C = Value of capacitance (F)
- R = Internal resistance ( $\Omega$ )
- PF = Power factor

Other important specifications for capacitors include:

- *Dielectric absorption* (DA): The reluctance of the dielectric to give up stored electrons when the capacitor is discharged. This is often called *memory* because if a capacitor is discharged through a resistance and the resistance is removed, the electrons that remain in the dielectric will reconvene on the electrode, causing a voltage to appear across the capacitor. DA is usually measured by charging the capacitor for 5 min, discharging it for 5 s, then having an open circuit for 1 min, after which the recovery voltage is read. The percentage of DA is defined as the ratio of recovery voltage to charging voltage times 100.
- *Dissipation factor* (DF): The ratio of the effective series resistance to capacitive reactance. DF normally is expressed as a percentage.
- *Leakage current*: The current flowing through the capacitor when a dc voltage is applied.
- *Insulation resistance*: The ratio of the applied voltage to the leakage current. Insulation resistance is normally expressed in megohms.
- *Ripple current/voltage*: The rms value of the maximum allowable alternating current or voltage (superimposed on any dc level) at a specific frequency at which the capacitor may be operated continuously at a specified temperature.
- *Surge voltage*: The maximum operating voltage of the capacitor at any temperature.

### 5.2.1 Series and Parallel Connections

The formulas for series and parallel connection of capacitors can be obtained from the general consideration of series and parallel connection of impedances [2]. For series connection

$$\frac{1}{sC} = \frac{1}{sC_1} + \frac{1}{sC_2} + \dots + \frac{1}{sC_n} \quad (5.8)$$

where  $C_1, C_2, \dots, C_n$  are the capacitances of the capacitors connected in series. Then, the equivalent capacitance  $C$  can be found as

$$C = \left( \frac{1}{C_1} + \frac{1}{C_2} + \dots + \frac{1}{C_n} \right)^{-1} \quad (5.9)$$

and is always less than the value of the smallest capacitance. This result can be used when the conditions for using the impedance concept are valid, that is, the capacitors are discharged.

The series connection of two capacitors has the equivalent capacitance

$$C = \frac{C_1 C_2}{C_1 + C_2} \quad (5.10)$$

In a similar way one can obtain the equivalent capacitance of parallel connection as

$$C = C_1 + C_2 + \dots + C_n \quad (5.11)$$

and is always larger than the largest capacitance.

Furthermore, the following two results are useful (for initially discharged capacitors):

- The voltage applied to two capacitors connected in series is divided between these two capacitors inversely proportionally to their capacitance (thus, the larger part of the voltage is on the smaller capacitance).

- The current applied to two capacitors connected in parallel is divided between these two capacitors proportionally to their capacitance (thus, the larger part of the current goes through the larger capacitance).

## 5.2.2 Practical Capacitors

Practical capacitors can be generally divided capacitors in four broad classes [2]:

- The first class includes low-loss capacitors with good capacitance stability. These are (in accordance with the dielectric) mica, glass, some ceramic, and low-loss plastic film (polypropylene, polystyrene) capacitors.
- The second class are capacitors of medium loss and medium stability designed to operate over a wide range of dc and ac voltages. These are paper (oil and wax impregnated), plastic film, and some ceramic capacitors. The dc applications include coupling, decoupling, bypass, smoothing and power separating filters, and energy storage. The ac applications include motor start, lightning, interference suppression, and power-line applications (switching and measurement equipment).
- The third class are aluminum and tantalum electrolytic capacitors providing high capacitance in a small size. For the same rated voltage tantalum capacitors have as much as three times larger capacitance per volume unit as aluminum, they are more reliable and have longer service life. The electrolytics are designed for dc and polarized voltage applications. Less-expensive aluminum capacitors are used in radio and television equipment; more expensive tantalum capacitors are destined for military and harsh environmental applications.
- The fourth class are fixed value capacitors (mica, glass, oil, gas, and vacuum) designed for high-voltage (up to 35 kV peak), high-current (up to 200 A) transmitter and power control applications.

The typical construction of common discrete capacitors is illustrated in [Figure 5.4](#). [Table 5.2](#) lists the characteristics of common capacitor types.

## 5.3 Capacitor Failure Modes

---

Experience has shown that capacitor failures are second only to semiconductors and vacuum tubes in components prone to malfunction in electronic equipment. Capacitors for ac applications range from high-voltage oil-filled devices, such as the one shown in [Figure 5.5](#), to low voltage, high capacitance devices of the type typically found in power supplies (both linear and switching). Of all the various types of capacitors used today, it is estimated that electrolytics present the greatest potential for problems to equipment users.

### 5.3.1 Electrolytic Capacitors

Electrolytic capacitors are popular because they offer a large amount of capacitance in a small physical size. They are widely used as filters in low-voltage power supplies and as coupling devices in audio and RF stages. An aluminum electrolytic capacitor consists of two aluminum foil plates separated by a porous strip of paper (or other material) soaked with a conductive electrolyte solution. Construction of a typical device is illustrated in [Figure 5.6](#). The separating material between the capacitor plates does not form the dielectric but, instead, serves as a spacer to prevent the plates from mechanically short-circuiting. The dielectric consists of a thin layer of aluminum oxide that is electrochemically formed on the positive foil plate. The electrolyte conducts the charge applied to the capacitor from the negative plate, through the paper spacer, and into direct contact with the dielectric. This sandwich arrangement of foil-spacer-foil is then rolled up and encapsulated.

Problems with electrolytic capacitors fall into two basic categories: mechanical failure and failure of electrolyte.

**Table 5.2** Parameters and Characteristics of Discrete Capacitors (After [2].)

Capacitor Type	Range	Rated Voltage, $V_R$	TC ppm/ °C	Tolerance, ±%	Insulation Resistance, MΩ μF	Dissipation Factor,%	Dielectric Absorption,%	Temperature Range, °C	Comments, Applications	Cost
Polycarbonate	100 pF – 30 μF	50 – 800	±50	10	$5 \times 10^5$	0.200	0.10	–55/+125	High quality, small, low TC	High
Polyester/Mylar	1000 pF – 50 μF	50 – 600	+400	10	$10^5$	0.750	0.30	–55/+125	Good, popular	Medium
Polypropylene	100 pF – 50 μF	100 – 800	–200	10	$10^5$	0.200	0.10	–55/+105	High quality, low absorption	High
Polystyrene	10 pF – 2.7 μF	100 – 600	–100	10	$10^6$	0.050	0.04	–55/+85	High quality, large, low TC, signal filters	Medium
Polysulfone	1000 pF – 1 μF	—	+80	5	$10^5$	0.300	0.20	–55/+150	High temperature	High
Parylene	5000 pF – 1 μF	—	±100	10	$10^5$	0.100	0.10	–55/+125	—	High
Kapton	1000 pF – 1 μF	—	+100	10	$10^5$	0.300	0.30	–55/+220	High temperature	High
Teflon	1000 pF – 2 μF	50 – 200	–200	10	$5 \times 10^6$	0.040	0.04	–70/+250	High temperature, lowest absorption	High
Mica	5 pF – 0.01 μF	100 – 600	–50	5	$2.5 \times 10^4$	0.001	0.75	–55/+125	Good at RF, low TC	High
Glass	5 pF – 1000 μF	100 – 600	+140	5	$10^6$	0.001	—	–55/+125	Excellent long-term stability	High
Porcelain	100 pF – 0.1 μF	50 – 400	+120	5	$5 \times 10^5$	0.100	4.20	–55/+125	Good long-term stability	High
Ceramic (NPO)	100 pF – 1 μF	50 – 400	±30	10	$5 \times 10^3$	0.020	0.75	–55/+125	Active filters, low TC	Medium
Ceramic	10 pF – 1 μF	50 – 30,000	—	—	—	—	—	–55/+125	Small, very popular, selectable TC	Low
Paper	0.01 – 10 μF	200 – 1,600	±800	10	$5 \times 10^3$	1.000	2.50	–55/+125	Motor capacitors	Low
Aluminum	0.1 – 1.6 F	3 – 600	+2500	–10/+100	100	10.000	8.00	–40/+85	Power supply filters	High
Tantalum (Foil)	0.1 – 1000 μF	6 – 100	+800	–10/+100	20	4.000	8.50	–55/+85	High capacitance, small size, low inductance	High
Thin-film	10 – 200 pF	6 – 30	+100	10	$10^6$	0.010	—	–55/+125	—	High
Oil	0.1 – 20 μF	200 – 10,000	—	—	—	0.500	—	—	High voltage filters, large, long life	—
Vacuum	1 – 1000 pF	2,000 – 3,600	—	—	—	—	—	—	Transmitters	—

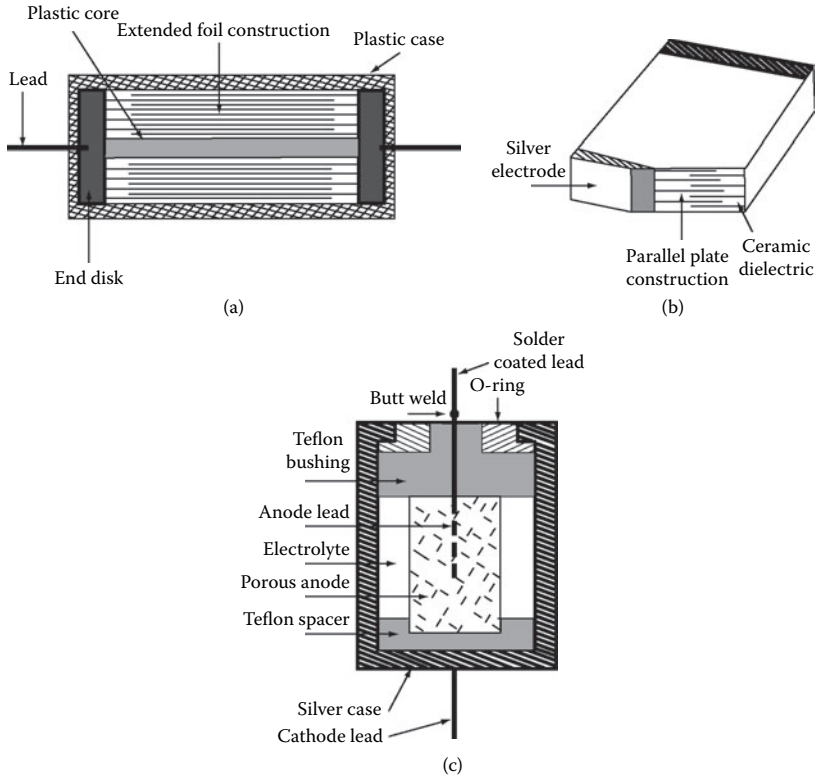


Figure 5.4 Construction of discrete capacitors. (From [2]. Used with permission.)

5.3.1.1 Mechanical Failure

Mechanical failures relate to poor bonding of the leads to the outside world, contamination during manufacture, and shock-induced short-circuiting of the aluminum foil plates. Typical failure modes include short circuits caused by foil impurities, manufacturing defects (such as burrs on the foil edges or tab connections), breaks or tears in the foil, and breaks or tears in the separator paper.

Short circuits are the most frequent failure mode during the useful life period of an electrolytic capacitor. Such failures are the result of random breakdown of the dielectric oxide film under normal stress. Proper capacitor design and processing will minimize such failures. Short circuits also can be caused by excessive stress, where voltage, temperature, or ripple conditions exceed specified maximum levels.

Open circuits, although infrequent during normal life, can be caused by failure of the internal connections joining the capacitor terminals to the aluminum foil. Mechanical connections can develop an oxide film at the contact interface, increasing contact resistance and eventually producing an open circuit. Defective weld connections also can cause open circuits. Excessive mechanical stress will accelerate weld-related failures.

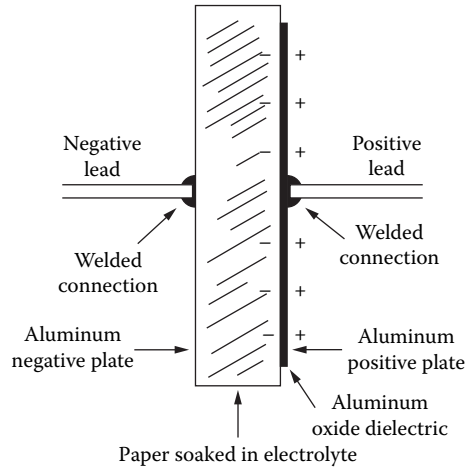


Figure 5.5 An oil-filled, high-voltage capacitor.

### 5.3.1.2 Temperature Cycling

Capacitors are subject to failures induced by thermal cycling. Experience has shown that thermal stress is a major contributor to failure in aluminum electrolytic capacitors. Dimensional changes between plastic and metal materials can result in microscopic ruptures at termination joints, possible electrode oxidation, and unstable device termination (changing series resistance). The highest-quality capacitor will fail if its voltage or current ratings are exceeded. Appreciable heat rise (20°C during a 2-hour period of applied sinusoidal voltage) is considered abnormal and may be a sign of incorrect application of the component or impending failure of the device.

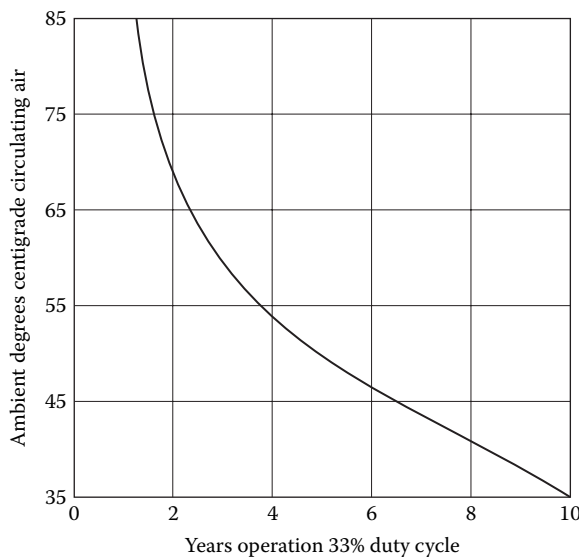
Figure 5.7 illustrates the effects of high ambient temperature on capacitor life. Note that operation at 33% duty cycle is rated at 10 years when the ambient temperature is 35°C, but the life expectancy drops to just 4 years when the same device is operated at 55°C. A common rule of thumb is this: Within the range of + 75°C through the full-rated temperature, stress and failure rates double for each 10°C increase in operating temperature. Conversely, the failure rate is reduced by half for every 10°C decrease in operating temperature.



**Figure 5.6** The basic design of an aluminum electrolytic capacitor.

### 5.3.1.3 Electrolyte Failures

Failure of the electrolyte can be the result of application of a reverse bias to the component or of a drying of the electrolyte itself. Electrolyte vapor transmission through the end seals occurs on a continuous basis throughout the useful life of the capacitor. This loss has no appreciable effect on reliability during the useful life period of the product cycle. When the electrolyte loss approaches 40% of the initial electrolyte content of the capacitor, however, the electrical parameters deteriorate and the capacitor is considered to be worn out.

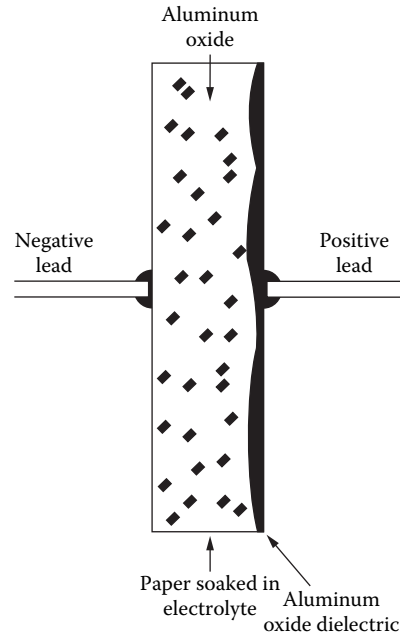


**Figure 5.7** Life expectancy of an electrolytic capacitor as a function of operating temperature.

As a capacitor dries out, three failure modes may be experienced: leakage, a downward change in value, or *dielectric absorption*. Any one of these can cause a system to operate out of tolerance or fail altogether.

The most severe failure mode for an electrolytic is increased leakage, illustrated in Figure 5.8. Leakage can cause loading of the power supply or upset the dc bias of an amplifier. Loading of a supply line often causes additional current to flow through the capacitor, possibly resulting in dangerous overheating and catastrophic failure.

A change of device operating value has a less devastating effect on system performance. An aluminum electrolytic has a typical tolerance range of about  $\pm 20\%$ . A capacitor suffering from drying of the electrolyte can experience a drastic drop in value (to just 50% of its rated value, or less). The reason for this phenomenon is that after the electrolyte has dried to an appreciable extent, the charge on the negative foil plate has no way of coming in contact with the aluminum-oxide dielectric. This failure mode is illustrated in Figure 5.9. Remember, it is the aluminum-oxide layer on the positive plate that gives the electrolytic capacitor its large rating. The dried-out paper spacer, in effect, becomes a second dielectric, which significantly reduces the capacitance of the device.

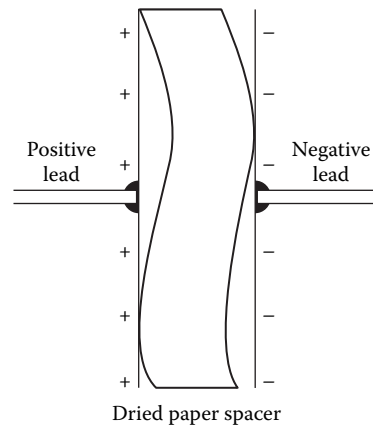


**Figure 5.8** Failure mechanism of a leaky aluminum electrolytic capacitor. As the device ages, the aluminum oxide dissolves into the electrolyte, causing the capacitor to become leaky at high voltages

### 5.3.2 Capacitor Life Span

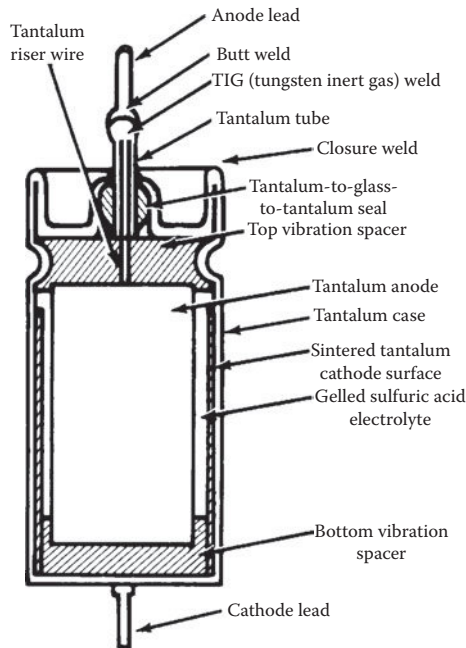
The life expectancy of a capacitor — operating in an ideal circuit and environment — will vary greatly, depending upon the grade of device selected. Typical operating life, according to capacitor manufacturer data sheets, range from a low of 3 to 5 years for inexpensive electrolytic devices, to a high of greater than 10 years for computer-grade products. Catastrophic failures aside, expected life is a function of the rate of electrolyte loss by means of vapor transmission through the end seals, and the operating or storage temperature. Properly matching the capacitor to the application is a key component in extending the life of an electrolytic capacitor. The primary operating parameters include:

- *Rated voltage* — the sum of the dc voltage and peak ac voltage that can be applied continuously to the capacitor. Derating of the applied voltage will decrease the failure rate of the device.
- *Ripple current* — the rms value of the maximum allowable ac current, specified by product type at 120 Hz and +85°C (unless otherwise noted). The ripple current may be increased when the component is operated at higher frequencies or lower ambient temperatures.



**Figure 5.9** Failure mechanism of an electrolytic capacitor exhibiting a loss of capacitance. After the electrolyte dries, the plates can no longer come in contact with the aluminum oxide. The result is a decrease in capacitor value.





**Figure 5.10** Basic construction of a tantalum capacitor.

- *Reverse voltage* — the maximum voltage that can be applied to an electrolytic capacitor without damage. Electrolytic capacitors are polarized and must be used accordingly.

### 5.3.3 Tantalum Capacitor

Tantalum electrolytic capacitors have become the preferred type of device where high reliability and long service life are primary considerations. The *tantalum pentoxide* compound possesses high dielectric strength and a high dielectric constant. As the components are being manufactured, a film of tantalum pentoxide is applied to the electrodes by means of an electrolytic process. The film is applied in various thicknesses. Figure 5.10 shows the internal construction of a typical tantalum capacitor. Because of the superior properties of tantalum pentoxide, tantalum capacitors tend to have as much as three times higher capacitance per volume efficiency as an aluminum electrolytic capacitor. This, coupled with the fact that extremely thin films can be deposited during the electrolytic process, makes tantalum capacitors efficient with respect to the number of microfarads per unit volume.

The capacitance of any device is determined by the surface area of the conducting plates, the distance between the plates, and the dielectric constant of the insulating material between the plates. In the tantalum capacitor, the distance between the plates is small; it is just the thickness of the tantalum pentoxide film. Tantalum capacitors contain either liquid or solid electrolytes.

## 5.4 References

1. Ballou, G., "Capacitors and Inductors," in *The Electrical Engineering Handbook*, R. C. Dorf (Ed.), p. 15, CRC Press, Boca Raton, FL, 1993.
2. Filanovsky, I. M., "Capacitance and Capacitors," in *The Electronics Handbook*, 2nd ed., J. C. Whitaker (Ed.), p. 371, CRC Press, Boca Raton, FL, 2005.

## 5.5 Bibliography

---

- Meeldijk, V., "Why Do Components Fail?" *Electronic Servicing & Technology*, Intertec Publishing, Overland Park, KS, November 1986.
- Technical staff, "Aluminum Electrolytic Capacitors: Reliability, Expected Life, and Shelf Capability," Sprague Applications Guide, Sprague Electric Company, Lansing, NC, 1989.
- Technical staff, "Introduction to Tantalum Capacitors," Sprague Applications Guide, Sprague Electric Company, Lansing, NC, 1989.

## 6.1 Introduction

---

The first line of defense in the protection of electronic equipment from damaging transient overvoltages is the ac-to-dc power supply. Semiconductor power-supply components are particularly vulnerable to failure from ac line disturbances. Devices occasionally will fail from one large transient, but many more fail because of smaller, more frequent spikes that punch through the device junction. Such occurrences explain why otherwise reliable systems fail “without apparent reason.”

## 6.2 Semiconductor Failure Modes

---

Semiconductor devices may be destroyed or damaged by transient disturbances in one of several ways. The primary failure mechanisms include:

- Avalanche-related failure
- Thermal runaway
- Thermal secondary breakdown
- Metallization failure
- Polarity reversals

When a semiconductor junction fails because of overstress, a low-resistance path is formed that shunts the junction. This path is not a true short, but it is a close approximation. The shunting resistance can be less than  $10\ \Omega$  in a junction that has been heavily overstressed. By comparison, the shunting resistance of a junction that has been only mildly overstressed can be as high as  $10\ \text{M}\Omega$ . The formation of low-resistance shunting paths is the result of the junction’s electrothermal response to overstress.

### 6.2.1 Device Ruggedness

The best-constructed device will fail if exposed to stress exceeding its design limits. The *safe operating area* (SOA) of a power transistor is the single most important parameter in the design of high-power semiconductor-based systems. Fortunately, advances in diffusion technology, masking, and device geometry have enhanced the power-handling capabilities of semiconductor devices.

A bipolar transistor exhibits two regions of operation that must be avoided:

- *Dissipation region* — where the voltage-current product remains unchanged over any combination of voltage ( $V$ ) and current ( $I$ ). Gradually, as the collector-to-emitter voltage increases, the electric field through the base region causes hot spots to form. The carriers may punch a hole in the junction by melting silicon. The result is a dead (short-circuited) transistor.
- *Second breakdown* ( $I_{s,b}$ ) *region* — where power transistor dissipation varies in a nonlinear inverse relationship with the applied collector-to-emitter voltage when the transistor is forward-biased.

To get SOA data into some type of useful format, a family of curves at various operating temperatures must be developed and plotted. This exercise gives a clear picture of what the data sheet indicates, compared with what happens in actual practice.

## 6.2.2 Forward Bias Safe Operating Area

The *forward bias safe operating area* (FBSOA) describes the ability of a transistor to handle stress when the base is forward-biased. Manufacturer FBSOA curves detail maximum limits for both steady-state dissipation and turn-on load lines. Because it is possible to have a positive base-emitter voltage and negative base current during the device storage time, forward bias is defined in terms of base current.

Bipolar transistors are particularly sensitive to voltage stress, more so than with stress induced by high currents. This situation is particularly true of switching transistors, and it shows up on the FBSOA curve. Figure 6.1 shows a typical curve for a common power transistor. In the case of the dc trace, the following observations can be made:

- The power limit established by the *bonding wire limit* portion of the curve permits 135 W maximum dissipation ( $15 \text{ A} \times 9 \text{ V}$ ).
- The power limit established by the *thermal limit* portion of the curve permits (at the maximum voltage point) 135 W maximum dissipation ( $2 \text{ A} \times 67.5 \text{ V}$ ). There is no change in maximum power dissipation.
- The power limit established by the *secondary breakdown* portion of the curve decreases dramatically from the previous two conditions. At 100 V, the maximum current is 0.42 A, for a maximum power dissipation of 42 W.

## 6.2.3 Reverse Bias Safe Operating Area

The *reverse bias safe operating area* (RBSOA) describes the ability of a transistor to handle stress with its base reverse-biased. As with FBSOA, RBSOA is defined in terms of current. In many respects, RBSOA and FBSOA are analogous. First among these is voltage sensitivity. Bipolar transistors exhibit the same sensitivity to voltage stress in the reverse bias mode as in the forward bias mode. A typical RBSOA curve is shown in Figure 6.2. Note that maximum allowable peak instantaneous power decreases significantly as voltage is increased.

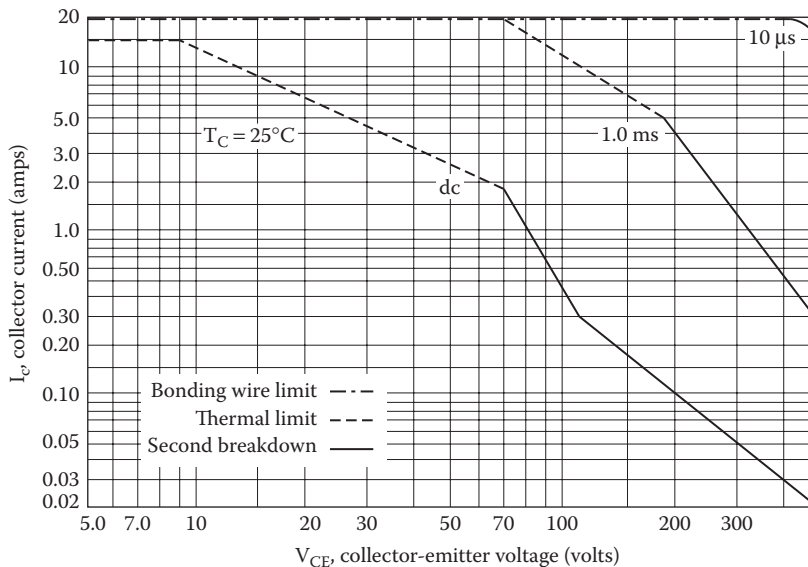
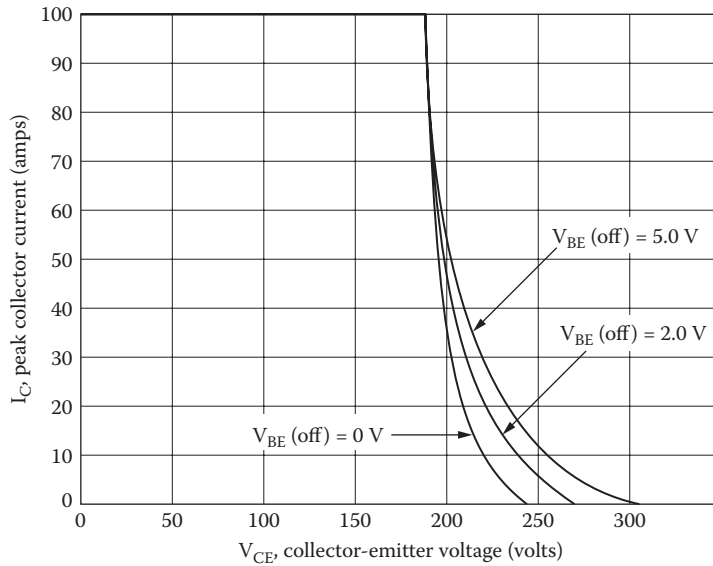


Figure 6.1 Forward bias safe operating area curve for a bipolar transistor (MJH16010A). (Courtesy of Motorola.)



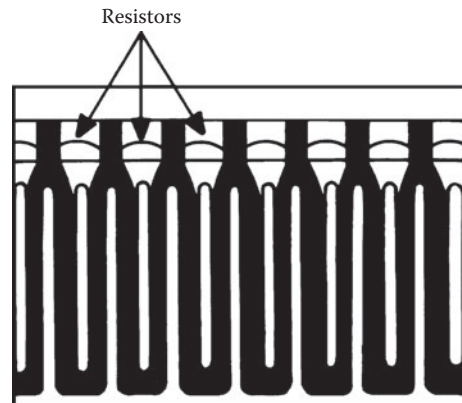
**Figure 6.2** Reverse bias safe operating area curve for a bipolar transistor (MJH10610A). (Courtesy of Motorola.)

### 6.2.4 Power-Handling Capability

The primary factor in determining the amount of power a given device can handle is the size of the active junction(s) on the chip. The same power output from a device can be achieved through the use of several smaller chips in parallel. This approach, however, may result in unequal currents and uneven distribution of heat. At high power levels, heat management becomes a significant factor in chip design.

Specialized layout geometries have been developed to ensure even current distribution throughout the device. One approach involves the use of a matrix of emitter resistances constructed so that the overall distribution of power among the parallel emitter elements results in even thermal dissipation. Figure 6.3 illustrates this *interdigitated* geometry technique.

With improvements in semiconductor fabrication processes, output device SOA is primarily a function of the size of the silicon slab inside the package. Package type, of course, determines the ultimate dissipation because of thermal saturation with temperature rise. A good TO-3 or a two-screw-mounted plastic package will dissipate approximately 350 to 375 W if properly mounted. Figure 6.4 demonstrates the relationships between case size and power dissipation for a TO-3 package.

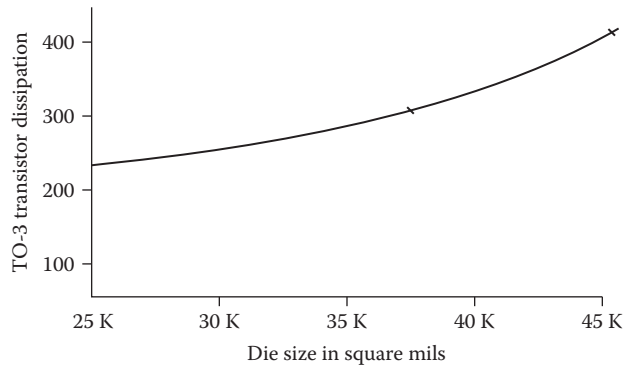


**Figure 6.3** Interdigitated geometry of emitter resistors used to balance currents throughout a power device chip.

### 6.2.5 Semiconductor Derating

Good engineering practice calls for a measure of caution in the selection and application of active devices. Unexpected operating conditions, or variations in the manufacturing process, can result in field failures unless a margin of safety is allowed. Derating is a common method of achieving such a margin. The primary derating considerations are:

- *Power derating* — designed to hold the worst-case junction temperature to a value below the normal permissible rating.
- *Junction-temperature derating* — an allowance for the worst-case ambient temperature or case temperature that the device is likely to experience in service.
- *Voltage derating* — an allowance intended to compensate for temperature-dependent voltage sensitivity and other threats to device reliability as a result of instantaneous peak-voltage excursions caused by transient disturbances.



**Figure 6.4** Relationship between case (die) size and transistor dissipation.

## 6.2.6 Failure Mechanisms

It is estimated that as much as 95% of all transistor failures in the field are directly or indirectly the result of excessive dissipation or applied voltages in excess of the maximum design limits of the device. There are at least four types of voltage breakdown that must be considered in a reliability analysis of discrete power transistors. Although they are not strictly independent, each type can be treated separately. Keep in mind, however, that each is related to the others.

### 6.2.6.1 Avalanche Breakdown

Avalanche is a voltage breakdown that occurs in the collector-base junction, similar to the *Townsend effect* in gas tubes. This effect is caused by the high dielectric field strength that occurs across the collector-base junction as the collector voltage is increased. This high-intensity field accelerates the free charge carriers so that they collide with other atoms, knocking loose additional free charge carriers that, in turn, are accelerated and have more collisions.

This multiplication process occurs at an increasing rate as the collector voltage increases, until at some voltage,  $V_a$  (avalanche voltage), the current suddenly tries to go to infinity. If enough heat is generated in this process, the junction will be damaged or destroyed. A damaged junction will result in higher-than-normal leakage currents, increasing the steady-state heat generation of the device, which ultimately can destroy the semiconductor junction.

### 6.2.6.2 Alpha Multiplication

Alpha multiplication is produced by the same physical phenomenon that produces avalanche breakdown, but differs in circuit configuration. This effect occurs at a lower potential than the avalanche voltage and generally is responsible for collector-emitter breakdown when base current is equal to zero.

### 6.2.6.3 Punch-Through

Punch-through is a voltage breakdown occurring at the collector-base junction because of high collector voltage. As collector voltage is increased, the *space charge region* (collector junction width) gradually increases until it penetrates completely through the base region, touching the emitter. At this point, the emitter and collector are effectively short-circuited together.

Although this type of breakdown occurs in some PNP junction transistors, alpha multiplication breakdown generally occurs at a lower voltage than punch-through. Because this breakdown occurs between the collector and emitter, punch-through is more serious in the common-emitter or common-collector configuration.

#### 6.2.6.4 Thermal Runaway

Thermal runaway is a regenerative process by which a rise in temperature causes an increase in the leakage current; in turn, the resulting increased collector current causes higher power dissipation. This action raises the junction temperature, further increasing leakage current.

If the leakage current is sufficiently high (resulting from high temperature or high voltage), and the current is not adequately stabilized to counteract increased collector current because of increased leakage current, this process can regenerate to a point that the temperature of the transistor rapidly rises, destroying the device. This type of effect is more prominent in power transistors, where the junction normally is operated at elevated temperatures and where high leakage currents are present because of the large junction area. Thermal runaway is related to the avalanche effect and is dependent upon circuit stability, ambient temperature, and transistor power dissipation.

### 6.3 MOSFET Devices

---

Power MOSFETs (*metal-oxide semiconductor field-effect transistors*) have found numerous applications because of their unique performance attributes. A variety of specifications can be used to indicate the maximum operating voltages a specific device can withstand. The most common specifications include:

- Gate-to-source breakdown voltage
- Drain-to-gate breakdown voltage
- Drain-to-source breakdown voltage

These limits mark the maximum voltage excursions possible with a given device before failure. Excessive voltages cause carriers within the depletion region of the reverse-biased PN junction to acquire sufficient kinetic energy to result in ionization. Voltage breakdown also can occur when a *critical electric field* is reached. The magnitude of this voltage is determined primarily by the characteristics of the die itself.

#### 6.3.1 Safe Operating Area

The safe dc operating area of a MOSFET is determined by the rated power dissipation of the device over the entire drain-to-source voltage range (up to the rated maximum voltage). The maximum drain-source voltage is a critical parameter. If exceeded even momentarily, the device can be damaged permanently.

Figure 6.5 shows a representative SOA curve for a MOSFET. Notice that limits are plotted for several parameters, including drain-source voltage, thermal dissipation (a time-dependent function), package capability, and drain-source on-resistance. The capability of the package to withstand high voltages is determined by the construction of the die, including bonding wire diameter, size of the bonding pad, and internal thermal resistances. The drain-source on-resistance limit is simply a manifestation of Ohm's law; with a given on-resistance, current is limited by the applied voltage.

To a large extent, the thermal limitations described in the SOA chart determine the boundaries for MOSFET use in linear applications. The maximum permissible junction temperature also affects the pulsed current rating when the device is used as a switch. MOSFETs are, in fact, more like rectifiers than bipolar transistors with respect to current ratings; their peak current ratings are not gain-limited, but thermally limited.

In switching applications, total power dissipation comprises both switching losses and on-state losses. At low frequencies, switching losses are small. As the operating frequency increases, however, switching losses become a significant factor in circuit design. The *switching safe operating area* (SSOA) defines the MOSFET voltage and current limitations during switching transitions. Although the SSOA chart outlines both turn-on and turn-off boundaries, it is used primarily as a source for turn-off SOA data. As such, it is the MOSFET equivalent of the reverse-biased SOA curve of bipolar transistors. As with the RBSOA rating, turn-off SOA curves are generated by observing device performance as it switches a clamped inductive load. Figure 6.6 shows a typical SSOA chart for a family of MOSFET devices.

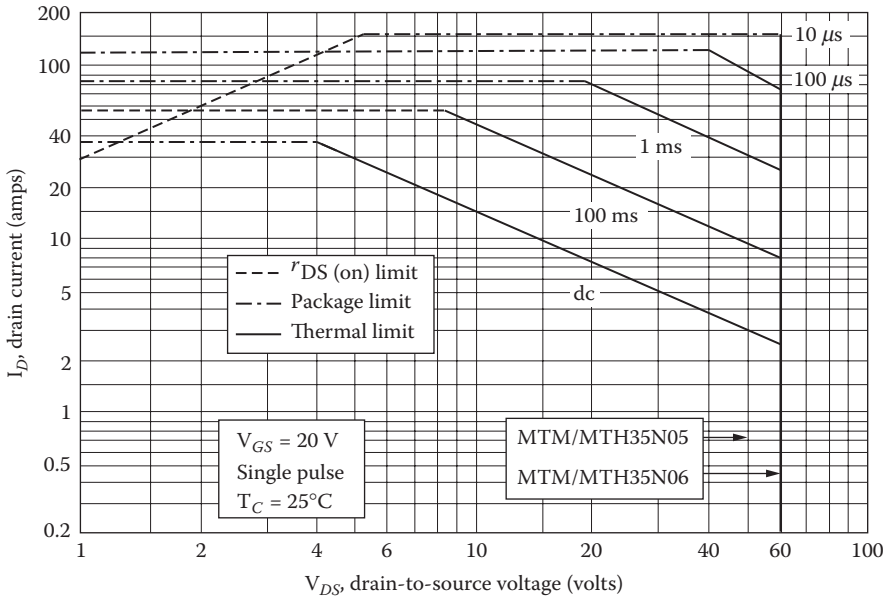


Figure 6.5 Safe operating area curve for a power FET device. (Courtesy of Motorola.)

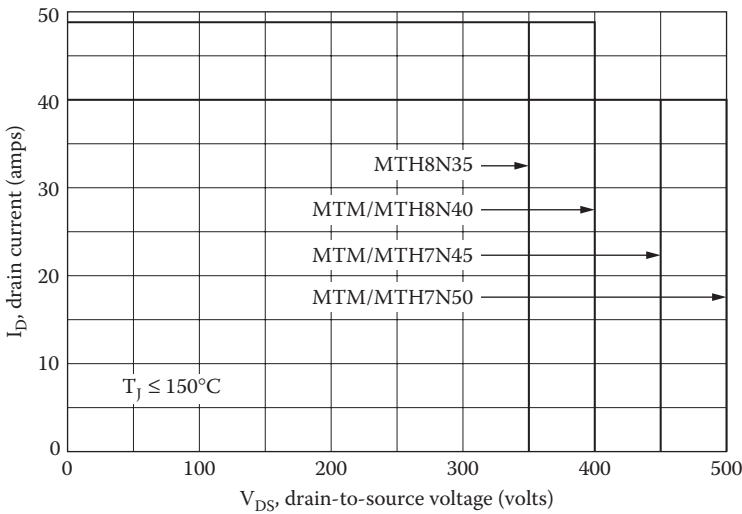


Figure 6.6 Maximum rated switching safe operating area of the MTM8N40 MOSFET. (Courtesy of Motorola.)

Figure 6.7 illustrates a FET device switching an inductive load in a circuit with no protection from fly-back (back-emf) voltages. The waveform depicts the turn-off voltage transient resulting from the load and the parasitic lead and wiring inductance. The device experiences an avalanche condition for about 300 ns at its breakdown voltage of 122 V. Placing a clamping diode across the inductive load suppresses most (but not all) of the transient. (See Figure 6.8.) The drain-to-source ( $V_{ds}$ ) voltage still will overshoot the supply rail by the sum of the effects of the diode's forward recovery characteristics, the diode lead inductance, and the parasitic series inductances. If the series resistance of the load is small in comparison with its inductance, a simple diode clamp may allow current to circulate through the load-diode loop for a significant period of time after the MOSFET is turned off. When this residual current is unacceptable, a resistance can be inserted in series with the diode at the expense of increasing the peak flyback voltage seen at the drain.



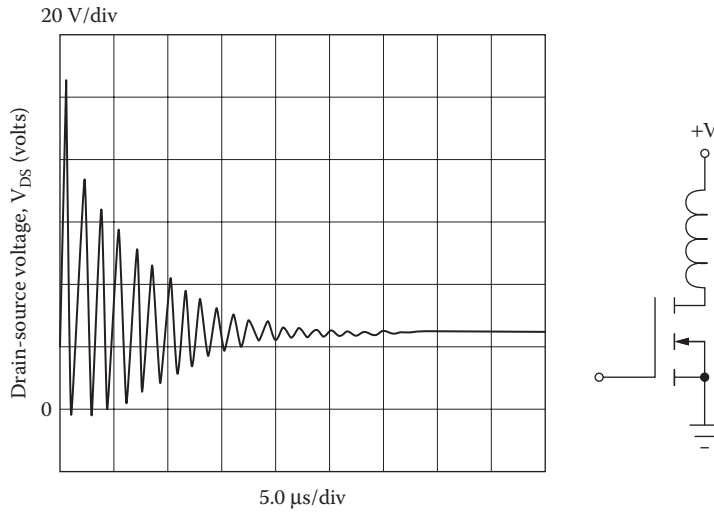


Figure 6.7 Drain-source transient resulting from switching off an unclamped inductive load. (Courtesy of Motorola.)

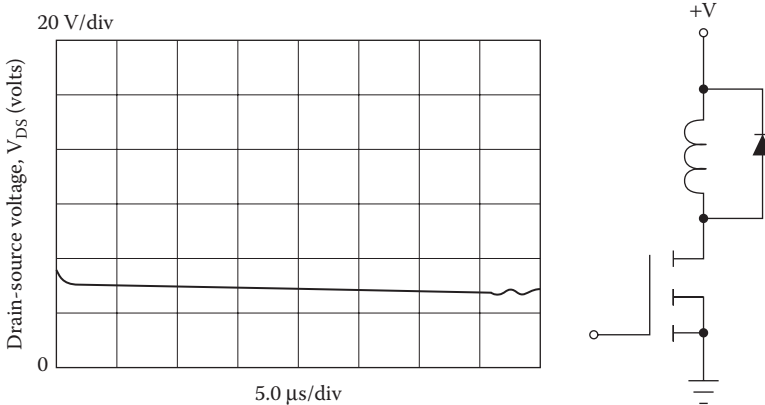


Figure 6.8 Drain-source transient with a clamping diode across the inductive load. (Courtesy of Motorola.)

Protecting the drain-source from voltage transients with a zener diode (a wideband device) is another simple and effective solution. Except for the effects of the lead and wiring inductances and the negligible time required to avalanche, the zener will clip the voltage transient at its breakdown voltage. A slow-rise-time transient will be clipped completely; a rapid-rise-time transient may momentarily exceed the zener breakdown. These effects are shown in Figure 6.9.

Figure 6.10 shows an RC clamp network that suppresses flyback voltages greater than the potential across the capacitor. Sized to sustain nearly constant voltage during the entire switch cycle, the capacitor absorbs energy only during transients and dumps that energy into the resistance during the remaining portion of the cycle.

A series RC snubber circuit is shown in Figure 6.11. Although the circuit effectively reduces the peak drain voltage, it is not as efficient as a true clamping scheme. Whereas a clamping network dissipates energy only during the transient, the RC snubber absorbs energy during portions of the switching cycle that are not overstressing the MOSFET. This configuration also slows turn-on times because of the additional drain-source capacitance that must be charged.

Historically, a MOSFET's maximum drain-to-source voltage specification prohibited even instantaneous excursions beyond stated limits; the first power MOSFET devices were never intended to be

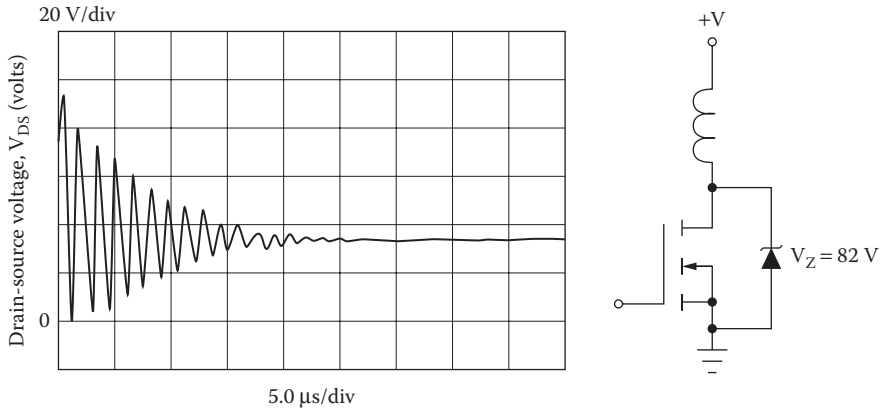


Figure 6.9 Drain-source transient with a clamping zener diode. (Courtesy of Motorola.)

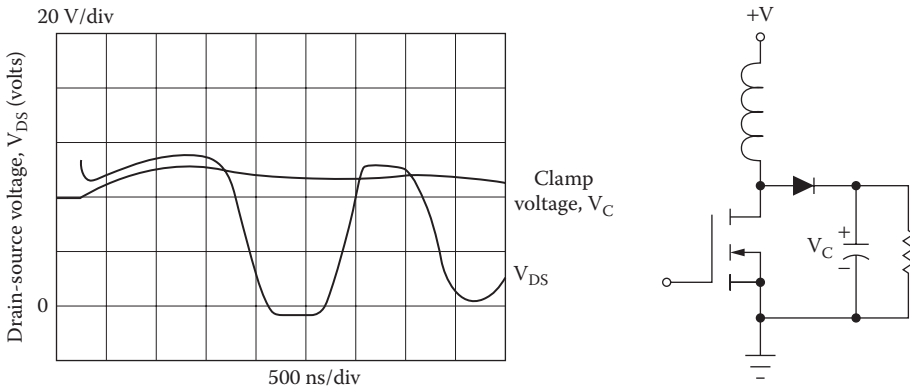


Figure 6.10 Transient waveforms for a gated RC clamp. (Courtesy of Motorola.)

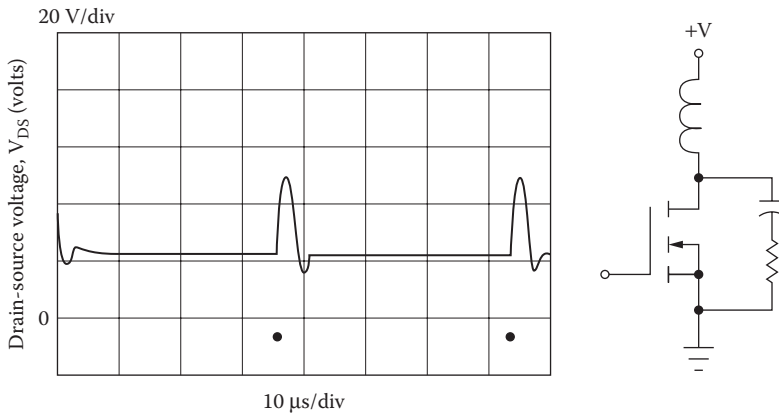


Figure 6.11 Drain-source transient with an RC snubber circuit. (Courtesy of Motorola.)

operated in avalanche. As is still the case with most bipolar transistors, avalanche limitations simply were not specified. Some devices happened to be rugged, whereas others were not. Manufacturers now have designed power MOSFET devices that are able to sustain substantial currents in avalanche at elevated junction temperatures. As a result, these “ruggedized” devices have replaced older MOSFETs in critical equipment.

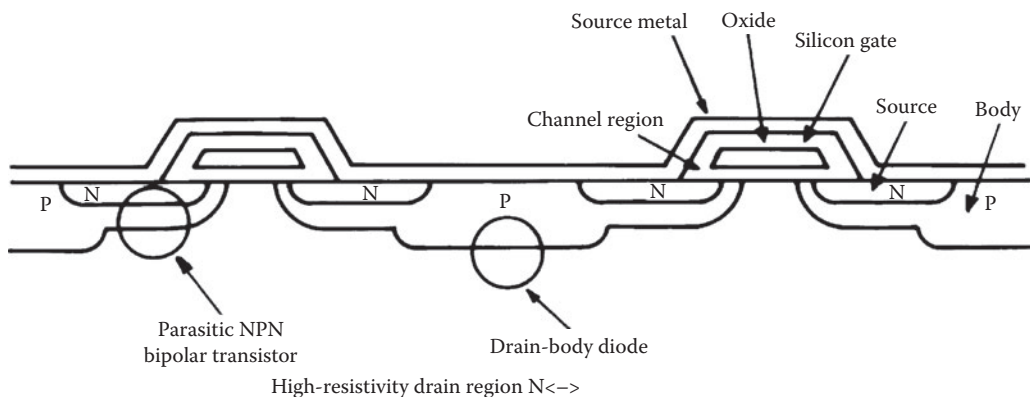
### 6.3.2 MOSFET Failure Modes

The thermal and electrical stresses that a MOSFET device may experience during switching can be severe, particularly during turn-off when an inductive load is present. When power MOSFETs were introduced, it usually was stated that, because the MOSFET was a majority carrier device, it was immune to secondary breakdown as observed in bipolar transistors. It must be understood, however, that a parasitic bipolar transistor is inherent in the structure of a MOSFET. This phenomenon is illustrated in Figure 6.12. The parasitic bipolar transistor can allow a failure mechanism similar to secondary breakdown. Research has shown that if the parasitic transistor becomes active, the MOSFET may fail. This situation is particularly troublesome if the MOSFET drain-source breakdown voltage is approximately twice the collector-emitter sustaining voltage of the parasitic bipolar transistor. This failure mechanism results, apparently, when the drain voltage snaps back to the sustaining voltage of the parasitic device. This *negative resistance characteristic* can cause the total device current to constrict to a small number of cells in the MOSFET structure, leading to device failure. The precipitous voltage drop synonymous with secondary breakdown is a result of avalanche injection and any mechanism, electric or thermal, that can cause the current density to become sufficiently large for avalanche injection to occur.

### 6.3.3 Breakdown Effects

The effects of the breakdown modes outlined manifest themselves in various ways on the transistor:

- Avalanche breakdown usually results in destruction of the collector-base junction because of excessive currents. This, in turn, results in an open between the collector and base.
- Breakdown due to alpha multiplication and thermal runaway most often results in destruction of the transistor because of excessive heat dissipation that shows up electrically as a short circuit between the collector and the emitter. This condition, which is most common in transistors that have suffered catastrophic failure, is not always detected easily. In many cases, an ohmmeter check may indicate a normal condition. Only after operating voltages are applied will the failure mode be exhibited.



**Figure 6.12** Cross section of a power MOSFET device showing the parasitic bipolar transistor and diode inherent in the structure.

- Punch-through breakdown generally does not cause permanent damage to the transistor; it can be a self-healing type of breakdown. After the overvoltage is removed, the transistor usually will operate satisfactorily.

### 6.3.3.1 Thermal Second Breakdown

Junction burnout is a significant failure mechanism for bipolar devices, particularly *junction field-effect transistor* (JFET) and Schottky devices. The junction between a P-type diffusion and an N-type diffusion normally has a positive temperature coefficient at low temperatures. Increased temperature will result in increased resistance. When a reverse-biased pulse is applied, the junction dissipates heat in a narrow *depletion region*, and the temperature in that area increases rapidly. If enough energy is applied in this process, the junction will reach a point at which the temperature coefficient of the silicon will turn negative. In other words, increased temperature will result in decreased resistance. A thermal runaway condition can then ensue, resulting in localized melting of the junction. If sustaining energy is available after the initial melt, the hot spot can grow into a *filament short*. The longer the energy pulse, the wider the resulting filament short. *Current filamentation* is a concentration of current flow in one or more narrow regions, which leads to localized heating.

After the transient has passed, the silicon will resolidify. The effect on the device can be catastrophic, or it can simply degrade the performance of the component. With a relatively short pulse, a hot spot can form, but not grow completely across the junction. As a result, the damage may not appear immediately as a short circuit, but manifest itself at a later time as a result of *electromigration* or another failure mechanism.

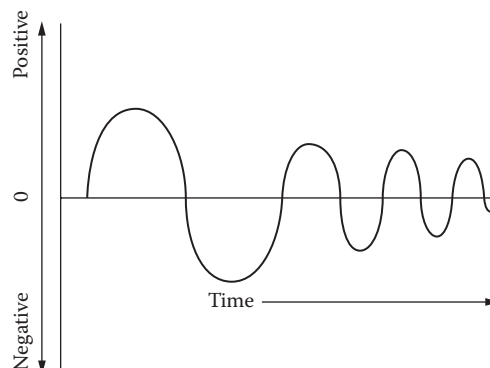
### 6.3.3.2 Metallization Failure

The smaller device geometry required by high-density integrated circuits has increased the possibility of metallization failure resulting from transient overvoltages. Metallization melt is a power-dependent failure mechanism. It is more likely to occur during a short-duration, high-current pulse. Heat generated by a long pulse tends to be dissipated in the surrounding chip die.

Metallization failure also can occur as a side effect of junction melt. The junction usually breaks down first, opening the way for high currents to flow. The metallization then heats until it reaches the melting point. Metallization failure results in an open circuit. A junction short circuit can, therefore, lead to an open-circuit failure.

### 6.3.3.3 Polarity Reversal

Transient disturbances typically build rapidly to a peak voltage and then decay slowly. If enough inductance or capacitance is present in the circuit, the tail will oscillate as it decays. This concept is illustrated in Figure 6.13. The oscillating tail can subject semiconductor devices to severe voltage polarity reversals, forcing the components into or out of a conducting state. This action can damage the semiconductor junction or result in catastrophic failure.



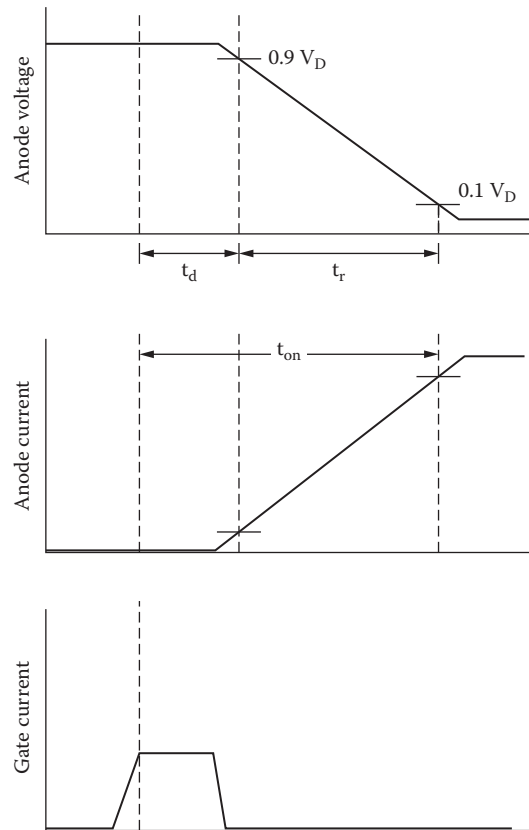
**Figure 6.13** Waveshape of a typical transient disturbance. Note how the tail of the transient oscillates as it decays.

## 6.4 Thyristor Components

The term *thyristor* identifies a general class of solid-state *silicon controlled rectifiers* (SCRs). These devices are similar to normal rectifiers, but are designed to remain in a blocking state (in the forward direction) until a small signal is applied to a control electrode (the gate). After application of the control pulse, the device conducts in the forward direction and exhibits characteristics similar to those of a common silicon rectifier. Conduction continues after the control signal has been removed and until the current through the device drops below a predetermined threshold, or until the applied voltage reverses polarity.

The voltage and current ratings for thyristors are similar to the parameters used to classify standard silicon rectifiers. Some of the primary device parameters include:

- *Peak forward blocking voltage* — the maximum safe value that can be applied to the thyristor while it is in a blocking state.
- *Holding current* — the minimum anode-to-cathode current that will keep the thyristor conducting after it has been switched on by the application of a gate pulse.
- *Forward voltage drop* — the voltage loss across the anode-to-cathode current path for a specified load current. Because the ratio of rms-to-average forward current varies with the angle of conduction, power dissipation for any average current also varies with the device angle of conduction. The interaction of forward voltage drop, phase angle, and device case temperature generally are specified in the form of one or more graphs or charts.
- *Gate trigger sensitivity* — the minimum voltage or current that must be applied to the gate to trigger a specific type of thyristor into conduction. This value must take into consideration variations in production runs and operating temperature. The minimum trigger voltage is not normally temperature sensitive, but the minimum trigger current can vary considerably with thyristor case temperature.
- *Turn-on time* — the length of time required for a thyristor to change from a nonconducting state to a conducting state. When a gate signal is applied to the thyristor, anode-to-cathode current begins to flow after a finite delay. A second switching interval occurs between the point at which current begins to flow and the point at which full anode current (determined by the instantaneous applied voltage and the load) is reached. The sum of these two times is the turn-on time. The turn-on interval is illustrated in Figure 6.14.



**Figure 6.14** Turn-on waveforms for an SCR device.  $T_d$  = delay time interval between a specified point at the beginning of a gate pulse and the instant at which the principal voltage drops to a specified value.  $T_r$  = rise time between the principal voltage dropping from one value to a second lower value when the thyristor turns from off to on.

- *Turn-off time* — the length of time required for a thyristor to change from a conducting state to a nonconducting state. The turn-off time is composed of two individual periods: the *storage time* (similar to the storage interval of a saturated transistor) and the *recovery time*. If forward voltage is reapplied before the entire turn-off time has elapsed, the thyristor will conduct again.

### 6.4.1 Failure Modes

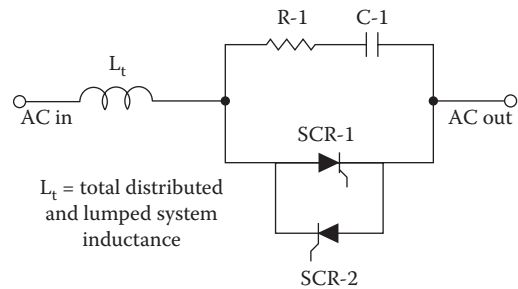
Thyristors, like diodes, are subject to damage from transient overvoltages because the peak inverse voltage or instantaneous forward voltage (or current) rating of the device may be exceeded. Thyristors face an added problem because of the possibility of device misfiring. A thyristor can break over into a conduction state, regardless of gate drive, if either of these conditions occur:

- Too high a positive voltage is applied between the anode and cathode.
- A positive anode-to-cathode voltage is applied too quickly, exceeding the  $dv/dt$  (delta voltage/delta time) rating.

If the leading edge is sufficiently steep, even a small voltage pulse can turn on a thyristor. This represents a threat not only to the device, but also to the load that it controls.

### 6.4.2 Application Considerations

Any application of a thyristor must take into account the device  $dv/dt$  rating and the electrical environment in which it will operate. A thyristor controlling an appreciable amount of energy should be protected against fast-rise-time transients that may cause the device to break over into a conduction state. The most basic method of softening the applied anode-to-cathode waveform is the resistor/capacitor snubber network shown in Figure 6.15. This standard technique of limiting the applied  $dv/dt$  relies on the integrating ability of the capacitor. In the figure,  $C_1$  snubs the excess transient energy, while  $R_1$  defines the applied  $dv/dt$  with  $L_t$ , the external system inductance.



**Figure 6.15** The basic RC snubber network commonly used to protect thyristors from fast-rise-time transients.

An applied transient waveform (assuming an infinitely sharp wavefront) will be impressed across the entire protection network of  $C_1$ ,  $R_1$ , and  $L_t$ . The total distributed and lumped system inductance  $L_t$  plays a significant role in determining the ability of  $C_1$  and  $R_1$  to effectively snub a transient waveform. Power sources that are *stiff* (having little series inductance or resistance) will present special problems to engineers seeking to protect a thyristor from steep transient waveforms.

Exposure of semiconductors to a high-transient environment can cause a degrading of the device, which eventually may result in total failure. Figure 6.16 shows the energy-vs.-survival scale for several types of semiconductors.

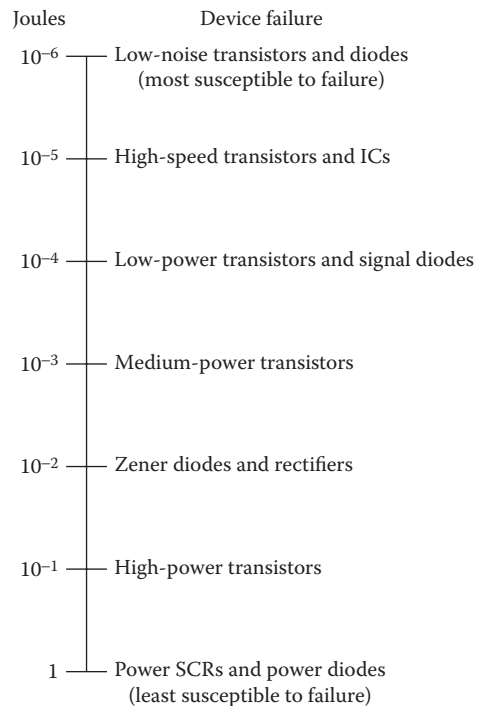
## 6.5 ESD Failure Modes

Low-power semiconductors are particularly vulnerable to damage from electrostatic discharges (ESDs). MOS devices tend to be more vulnerable than other components. The gate of a MOS transistor is especially sensitive to electrical overstress. Application of excessive voltage can exceed the dielectric standoff voltage of the chip structure and punch through the oxide, forming a permanent path from the gate to the semiconductor below. An ESD pulse of 25 kV usually is sufficient to rupture the gate oxide. The scaling of device geometry that occurs with large-scale integrated (LSI) or very large-scale integrated (VLSI) components complicates this problem. The degree of damage caused by electrostatic discharge is a function of the following parameters:

- Size of the charge, determined by the capacitance of the charged object
- Rate at which the charge is dissipated, determined by the resistance into which it is discharged

Common techniques for controlling static problems include the following:

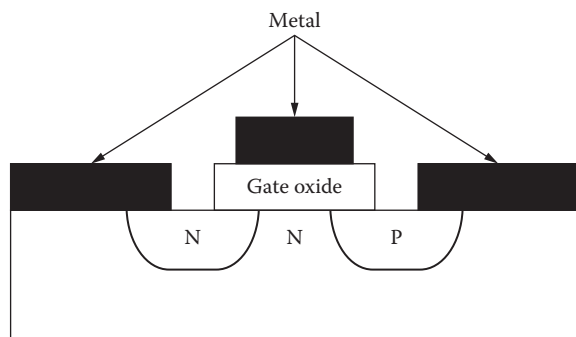
- Humidity control. Relative humidity (RH) of 50% or higher will greatly inhibit electrostatic problems. Too much humidity, however, can create corrosion problems and may make some paper products dimensionally unstable. Most data processing equipment manufacturers recommend 40 to 60% RH.
- Conductive floor coverings. Careful selection of floor surfaces will aid greatly in controlling ESD problems. Conductive synthetic rubber and other special-purpose floor coverings are ideal. Vinyl-asbestos is marginal. Nylon carpeting usually is unacceptable from an ESD standpoint.
- Static drain path. A static drain path from floor tiles or mats to the nearest grounded metal member is recommended in heavy traffic areas. The floor surface-to-ground resistance need not be particularly low; 500 k $\Omega$  to 20 M $\Omega$  is adequate for most applications.
- Ion generators. Localized, chronic static problems can be neutralized through the use of an ion generator. Such systems commonly are used in semiconductor assembly plants and in the printing industry to dissipate static charges.



**Figure 6.16** An estimate of the susceptibility of semiconductor devices to failure because of transient energy. The estimate assumes a transient duration of several microseconds.

### 6.5.1 Failure Mechanisms

Destructive voltages or currents from an ESD event can result in device failure because of thermal fatigue or dielectric breakdown. MOS transistors normally are constructed with an oxide layer between the gate conductor and the source-drain channel region, as illustrated in Figure 6.17 for a metal gate device and Figure 6.18 for a silicon gate device. Bipolar transistor construction, shown in Figure 6.19, is less susceptible to ESD damage because the oxide is used only for surface insulation.



**Figure 6.17** Construction of a metal gate NMOS transistor. (After [1].)

Oxide thickness is the primary factor in MOS ruggedness. A thin oxide is more susceptible to electrostatic punch-through, which results in a permanent low-resistance short-circuit through the oxide. Where pinholes or other weaknesses exist in the oxide, damage is possible at a lower charge level. Semiconductor manufacturers have reduced oxide thickness as they have reduced device size. This trend has resulted in a significant increase in sensitivity to ESD damage.

Detecting an ESD failure in a complex device can present a significant challenge for quality control engineers. For example, erasable programmable read-only memory (EPROM) chips use oxide layers less than 100 angstroms, making them susceptible to single-cell defects that can remain undetected until the damaged cell itself is addressed. An electrostatic charge small enough that it does not result in oxide breakdown still can cause lattice damage in the oxide, lowering its ability to withstand subsequent ESD exposure. A weakened lattice will have a lower breakdown threshold voltage.

Table 6.1 lists the susceptibility of various semiconductor technologies to ESD-induced failure. Table 6.2 lists the ESD voltage levels that can result from common workbench operations.

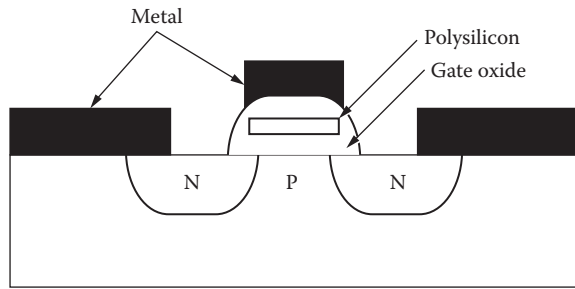


Figure 6.18 Construction of a silicon gate NMOS transistor. (After [1].)

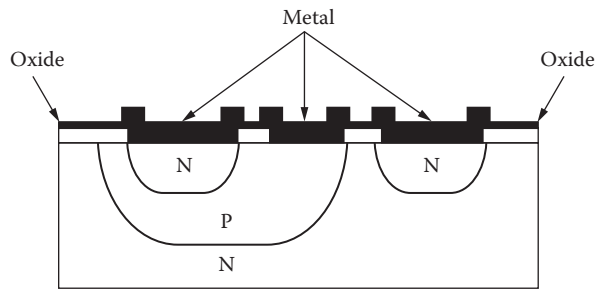


Figure 6.19 Construction of a bipolar transistor. (After [1].)

Table 6.1 The Susceptibility of Various Technologies from ESD-Induced Damage (Data courtesy of Motorola.)

Device Type	Range of ESD Susceptibility (V)
Power MOSFET	100 to 2,000
Power Darlington	20,000 to 40,000
JFET	140 to 10,000
Zener diode	40,000
Schottky diode	300 to 2,500
Bipolar transistor	380 to 7,000
CMOS	250 to 2,000
ECL	500
TTL	300 to 2,500

Table 6.2 Electrostatic Voltages That Can Be Developed through Common Workbench Activities (Data courtesy of Motorola.)

Means of Static Generation	Electrostatic Voltages	
	10–20% RH	65–90% RH
Walking across carpet	35,000	1,500
Walking on vinyl floor	12,000	250
Worker at bench	6,000	100
Handling vinyl envelope	7,000	600
Handling common polybag	20,000	1,200



### 6.5.1.1 Latent Failures

Immediate failure resulting from ESD exposure is easily determined: the device no longer works. A failed component can be removed from the subassembly in which it is installed, representing no further reliability risk to the system. Not all devices exposed to ESD, however, fail immediately. Unfortunately, there is little data dealing with the long-term reliability of devices that have survived ESD exposure. Some experts, however, suggest that two to five devices are degraded for every one that fails. Available data indicates that latent failures can occur in both bipolar and MOS chips and that there is no direct relationship between the susceptibility of a device to catastrophic failure and its susceptibility to latent failure. Damage can manifest itself in one of two primary mechanisms:

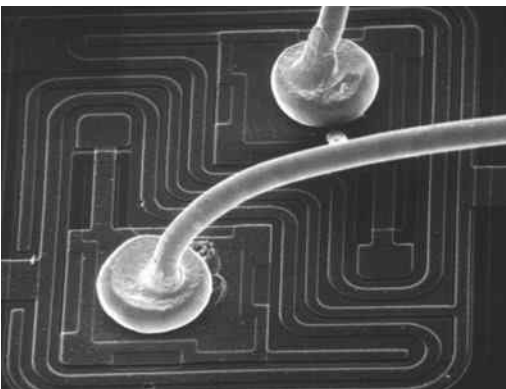
- Shortened lifetime, a possible cause of many infant mortality failures seen during burn-in
- Electrical performance shifts, many of which can cause the device to fail electrical limit tests

### 6.5.1.2 Case in Point

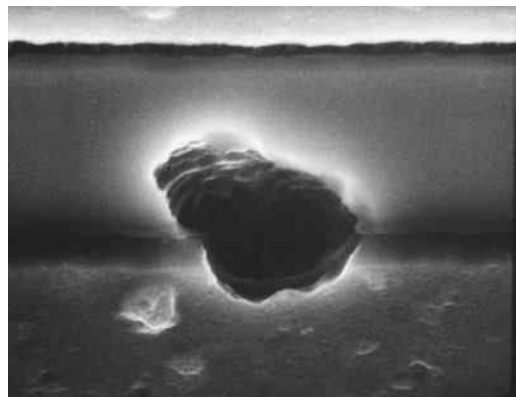
Figure 6.20 shows an electron microscope photo of a chip that failed because of an overvoltage condition. An ESD to this MOSFET damaged one of the metallization connection points of the device, resulting in catastrophic failure. Note the spot where the damage occurred. The objects in the photo that look like bent nails are actually gold lead wires with a diameter of 1 mil. By contrast, a typical human hair is about 3 mils in diameter. The original photo was shot at  $\times 200$  magnification. Figure 6.21 offers another view of the MOSFET damage point, but at  $\times 5000$ . The character of the damage can be observed. Some of the aluminum metallization has melted and can be seen along the bottom edge of the hole.

## 6.6 Semiconductor Development

Semiconductor failures caused by high-voltage stresses are becoming a serious concern for engineers, operators, and technical managers as new, high-density integrated circuits are placed into service. Internal IC connection lines that were 1.0 micron a few years ago have been reduced to well below 0.30 micron. Spacing between leads has been reduced by a factor of 4 or more. The most common microprocessors, and many other ICs, are manufactured using a planar process where a pure silicon wafer is selectively masked and diffused with chemicals to make multiple transistors. This combination is then selectively masked again, and metal is deposited on the wafer to interconnect the transistors [2]. A decade ago, most integrated circuits used only one layer of metal; today, however, advanced microprocessors use multiple layers of metal to increase the packing density. A cross section of a five-layer microprocessor is shown in Figure 6.22.



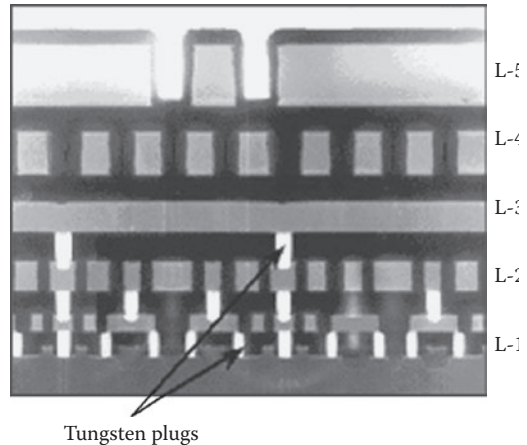
**Figure 6.20** A scanning electron microscope photo illustrating ESD damage to the metallization of a MOSFET device.



**Figure 6.21** The device shown in the previous figure at  $\times 5000$  magnification. The character of the damage can be observed.

As the geometries of the individual transistors are reduced, the propagation delays through the devices also become smaller. Unfortunately, as the metalized interconnects get smaller, their resistance and capacitance increases and, therefore, the propagation delay through those interconnects increases. As the semiconductor industry moves to still smaller geometries, the delay through the metal will become greater than the delay through the transistor itself. There are several approaches to this challenge — the most obvious being to use a metal with higher conductivity than aluminum (currently used in chip production). Copper offers some attractive solutions but is more difficult to process. Alternative design techniques that use more transistors and fewer interconnects are also possible.

As the transistor count goes up, then so does the power dissipation. More importantly, however, is the corresponding increase in frequency (power increases as the square of the frequency). The only variable that is changeable in the power equation is the supply voltage — power dissipation also is proportional to the square of the voltage. This operating limitation is the reason for movement to low-voltage microprocessors and other logic devices.



**Figure 6.22** Cross section of a five-layer microprocessor device. (From [2]. Courtesy of Intel.)

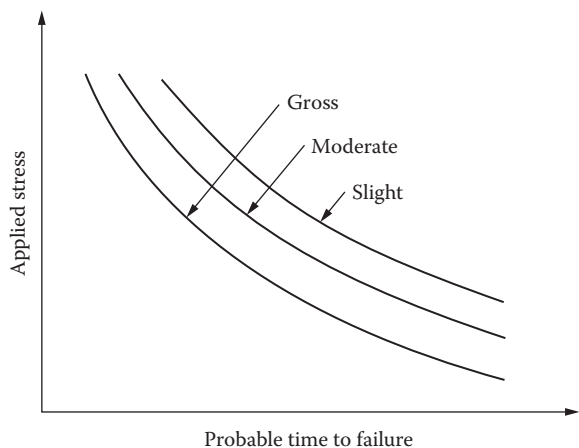
### 6.6.1 Failure Analysis

In the past, the IC overvoltage peril was primarily to semiconductor substrates. Now, however, the metalization itself—the points to which leads connect — is subject to damage. Failures are the result of three primary overvoltage sources:

- External human-made — overvoltages coupled into electronic hardware from utility company ac power feeds, or other ac or dc power sources
- External natural — overvoltages coupled into electronic hardware as a result of natural sources
- Electrostatic discharge — overvoltages coupled into electronic hardware as a result of static generation and subsequent discharge

Most semiconductor failures are of a random nature. That is, different devices respond differently to a specific stress. Figure 6.23 illustrates how built-in (latent) defects in a given device affect the time-to-failure point of the component. Slight imperfections require greater stress than gross imperfections to reach a quantifiable failure mode.

Integrated circuits intended for computer applications have been a driving force in the semiconductor industry. Figure 6.24 shows a simplified cutaway view of a DIP IC package. Connections between the die itself and the outside world are made with bonding wires. Figure 6.25 shows a cutaway view of a bonding pad.



**Figure 6.23** Illustration of the likelihood of component failure based on applied stress and degree of latent defects.

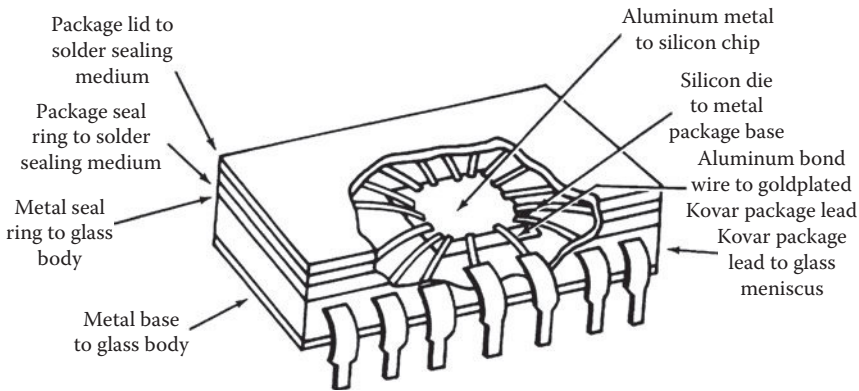


Figure 6.24 Cutaway view of a DIP integrated circuit package showing the internal-to-external interface. (After [1].)

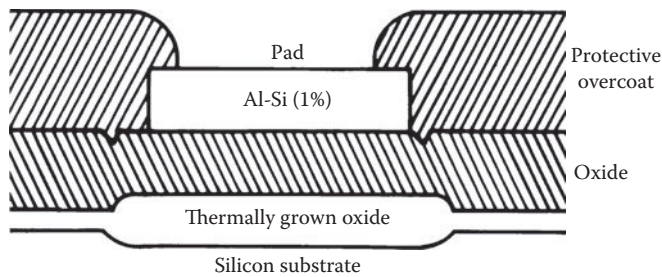


Figure 6.25 Cutaway structure of the bonding pad of a semiconductor device. (After [3].)

Hybrid microcircuits also have become common in consumer and industrial equipment. A hybrid typically utilizes a number of components from more than one technology to perform a function that could not be achieved in monolithic form with the same performance, efficiency, or cost. A simple multi-chip hybrid is shown in Figure 6.26.

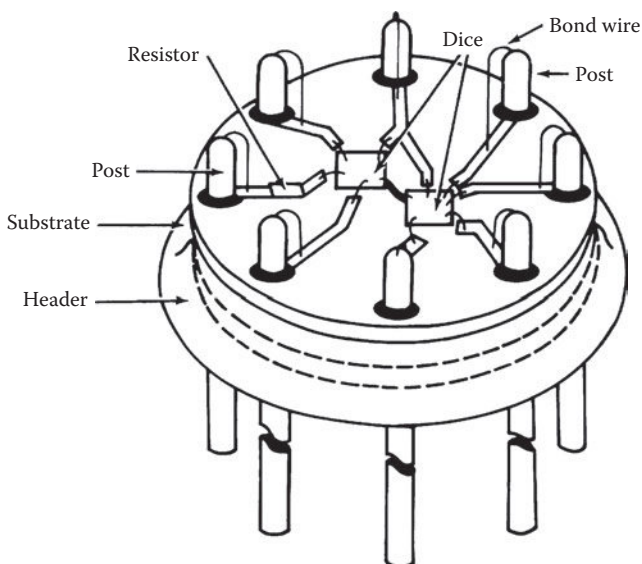
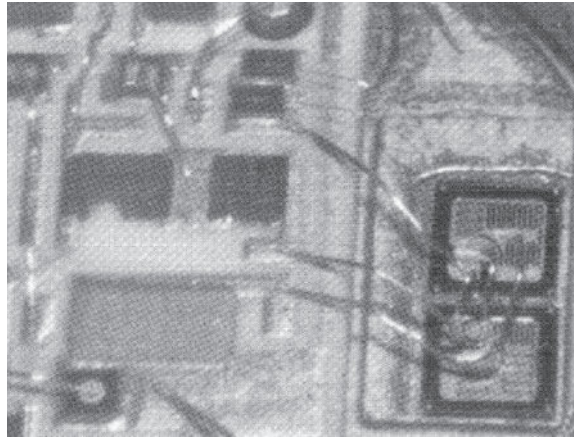


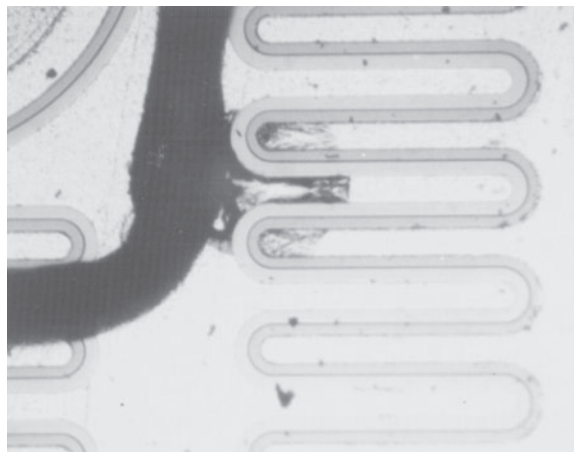
Figure 6.26 Basic construction of a multichip hybrid device. (After [1].)



(a)



(b)



(c)

**Figure 6.27** Three views of a hybrid voltage regulator that failed because of a damaged pass transistor: (a) the overall circuit geometry; (b) a closeup of the damaged pass transistor area; (c) an enlarged view of the damage point.

The effects of high-voltage breakdown in a hybrid semiconductor chip are illustrated graphically in Figure 6.27a to c. Failure analysis indicated that the pass transistor in this voltage regulator device was overstressed because of excessive input/output voltage differential.

## 6.6.2 Chip Protection

With the push for faster and more complex ICs, it is unlikely that semiconductor manufacturers will return to thicker oxide layers or larger junctions. Overvoltage protection must come, instead, from circuitry built into individual chips to shunt transient energy to ground.

Most MOS circuits incorporate protective networks. These circuits can be made quite efficient, but there is a tradeoff between the amount of protection provided and device speed and packing density. Protective elements, usually diodes, must be physically large if they are to clamp adequately. Such elements take up a significant amount of chip space. The RC time constants of protective circuits also can place limits on switching speeds.

Protective networks for NMOS devices typically use MOS transistors as shunting elements, rather than diodes. Although diodes are more effective, fewer diffusions are available in the NMOS process, so not as many forward-biased diodes can be constructed. Off-chip protective measures, including electro-magnetic shielding, filters, and discrete diode clamping, are seldom used because they are bulky and expensive.

Figure 6.28 shows the protective circuitry used in a 54HC high-speed *complementary metal-oxide silicon* (CMOS) device. Polysilicon resistors are placed in series with each input pin, and relatively large-geometry diodes are added as clamps on the IC side of the resistors. Clamping diodes also are used at the output. The diodes restrict the magnitude of the voltages that can reach the internal circuitry. Protective features such as these have allowed CMOS devices to withstand ESD test voltages in excess of 2 kV.

## 6.7 Effects of Arcing

High voltages often are generated by breaking current to an inductor with a mechanical switch. They can, with time, cause pitting, corrosion, or material transfer of the switch contacts. In extreme cases, the contacts even can be welded together. The actual wear (or failure) of a mechanical switch is subject to many factors, including:

- Contact construction and the type of metal used
- Amount of contact bounce that typically occurs with the switching mechanism
- Atmosphere
- Temperature
- Steady-state and in-rush currents
- Whether ac or dc voltages are being switched by the mechanism

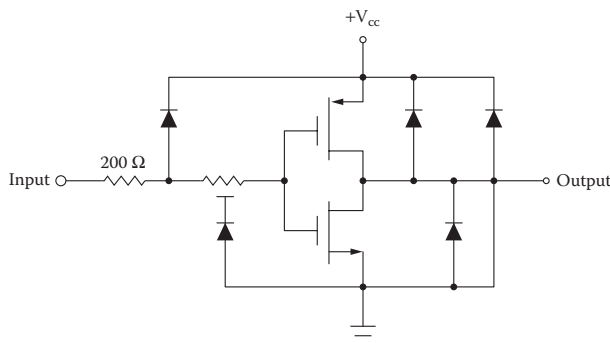


Figure 6.28 CMOS transistor with built-in ESD protection circuitry. (After [1].)



Effective transient suppression can significantly reduce the amount of energy dissipated during the operation of switch contacts. This reduction will result in a corresponding increase in switch life. In applications where relay contacts are acting as power-switching elements, the use of effective transient-suppression techniques will reduce the amount of maintenance (contact cleaning) required for the device.

### 6.7.1 Insulation Breakdown

The breakdown of a solid insulating material usually results in localized carbonization, which may be catastrophic, or may result in decreased dielectric strength at the arc-over point. The occurrence of additional transients often will cause a breakthrough at the weakened point in the insulating material, eventually resulting in catastrophic failure of the insulation. Similar problems can occur within the windings of a transformer or coil. Arcing between the windings of an inductor often is caused by self-induced voltages with steep wavefronts that are distributed unevenly across the turns of the coil. Repetitive arcing between windings can cause eventual failure of the device.

Printed wiring board (PWB) arcing can result in system failure modes in ways outlined for insulating materials and coils. A breakdown induced by high voltage along the surface of a PWB can create a conductive path of carbonized insulation and vaporized metal from the printed wiring traces or component leads.

The greatest damage to equipment from insulation breakdown caused by transient disturbances generally occurs *after* the spike has passed. The *follow-on* steady-state current that can flow through fault paths created by a transient often cause the actual component damage and system failure.

## 6.8 References

---

1. Technical staff, Military/Aerospace Products Division, *The Reliability Handbook*, National Semiconductor, Santa Clara, CA, 1987.
2. Technical staff, "Moore's Law: Changing the PC Platform for Another 20 Years," Intel Corporation Web site, [www.intel.com](http://www.intel.com), 1998.
3. Ching, T. B., and W. H. Schroen, "Bond Pad Structure Reliability," *Proceedings of the IEEE Reliability Physics Symposium*, IEEE, New York, 1988.

## 6.9 Bibliography

---

- Antinone, R. J., "How to Prevent Circuit Zapping," *IEEE Spectrum*, IEEE, New York, April 1987.
- Benson, K. B., and J. C. Whitaker, *Television and Audio Handbook for Engineers and Technicians*, McGraw-Hill, New York, 1989.
- Blackburn, D. L., "Turn-Off Failure of Power MOSFETs," *IEEE Transactions on Power Electronics*, Vol. PE-2, No. 2, IEEE, New York, April 1987.
- Boxleitner, W., "How to Defeat Electrostatic Discharge," *IEEE Spectrum*, IEEE, New York, August 1989.
- Crook, D. L., "Evolution of VLSI Reliability Engineering," *Proceedings of the IEEE Reliability Physics Symposium*, IEEE, New York, 1990.
- Federal Information Processing Standards Publication No. 94, *Guideline on Electrical Power for ADP Installations*, U.S. Department of Commerce, National Bureau of Standards, Washington, D.C., 1983.
- Frank, D., "Please Keep Your EMC Out of My ESD," *Proceedings, IEEE Reliability and Maintainability Symposium*, IEEE, New York, 1986.
- Gloer, H. N., "Voltage Transients and the Semiconductor," *The Electronic Field Engineer*, Vol. 2, 1979.
- Jordan, E. C. (Ed.), *Reference Data for Engineers: Radio, Electronics, Computer, and Communications*, 7th ed., Howard W. Sams Company, Indianapolis, IN, 1985.

- Kanarek, J., "Protecting against Static Electricity Damage," *Electronic Servicing & Technology*, Intertec Publishing, Overland Park, KS, March 1986.
- Koch, T., W. Richling, J. Witlock, and D. Hall, "A Bond Failure Mechanism," *Proceedings, IEEE Reliability Physics Conference*, IEEE, New York, April 1986.
- Meeldijk, V., "Why Do Components Fail?" *Electronic Servicing & Technology*, Intertec Publishing, Overland Park, KS, November 1986.
- Motorola TMOS Power MOSFET Data Handbook*, Motorola Semiconductor, Phoenix, AZ.
- Nenoff, L., "Effect of EMP Hardening on System R&M Parameters," *Proceedings, IEEE Reliability and Maintainability Symposium*, IEEE, New York, 1986.
- SCR Applications Handbook*, International Rectifier Corporation, El Segundo, CA, 1977.
- SCR Manual*, 5<sup>th</sup> ed., General Electric Company, Auburn, NY.
- Sydnor, A., "Voltage Breakdown in Transistors," *Electronic Servicing & Technology*, Intertec Publishing, Overland Park, KS, July 1986.
- Technical staff, *Bipolar Power Transistor Reliability Report*, Motorola Semiconductor, Phoenix, AZ, 1988.
- Technical staff, *MOV Varistor Data and Applications Manual*, General Electric Company, Auburn, NY.
- Voss, M., "The Basics of Static Control," *Electronic Servicing & Technology*, Intertec Publishing, Overland Park, KS, July 1988.
- Whitaker, J., *Electronic Systems Maintenance Handbook*, 2nd ed., CRC Press, Boca Raton, FL, 2002.

# Rectifier and Filter Circuits

---

## 7.1 Introduction

---

The circuit elements most vulnerable to failure in any given piece of electronic hardware are those exposed to the outside world. In most systems, the greatest threat generally involves the ac-to-dc power supply. The power supply is subject to high-energy surges from lightning and other sources. Because power-supply systems often are exposed to extreme voltage and environmental stresses, derating of individual components is a key factor in improving supply reliability. The goal of derating is to reduce the electrical, mechanical, thermal, and other environmental stresses on a component to decrease the degradation rate and to prolong useful life. Through derating, the margin of safety between the operating stress level and the maximum permissible stress level for a given part is increased. This consideration provides added protection from system overstress, unforeseen during design.

Experience has demonstrated that types of components tend to fail in predictable ways. Table 7.1 shows the statistical distribution of failures for a transient-suppression (EMP) protection circuit. Although the data presented applies only to a specific product, some basic conclusions can be drawn:

- The typical failure mode for a capacitor is a short circuit.
- The typical failure mode for a zener diode is a short circuit.
- The typical failure mode for a connector pin is an open circuit.
- The typical failure mode for a solder joint is an open circuit.

These conclusions present no great surprises, but they point out the predictability of equipment failure modes. The first step in solving a problem is knowing what is likely to fail and what the typical failure modes are.

**Table 7.1** Statistical Distribution of Component Failures in an EMP Protection Circuit  
(After [1].)

Component	Mode of Failure	Distribution
Capacitor (all types)	Open	0.01
	Short	0.99
Coil	Open	0.75
	Short	0.25
Diode (zener)	Open	0.01
	Short	0.99
GE-MOV	Open	0.01
	Short	0.99
Transzorb	Open	0.01
	Short	0.99
Connector pin	Open	0.99
	Short to ground	0.01
Solder joint	Open	1.00
Lug connection	Open	1.00
Surge protector	Open	0.99
	Short	0.01



## 7.2 Power Rectifiers

Virtually all power supplies use silicon rectifiers as the primary ac-to-dc converting device. Rectifier parameters generally are expressed in terms of reverse-voltage ratings and mean-forward-current ratings in a  $f$ -wave rectifier circuit operating from a 60 Hz supply and feeding a purely resistive load. The three primary reverse-voltage ratings are:

- *Peak transient reverse voltage* ( $V_{rm}$ ) — the maximum value of any nonrecurrent surge voltage. This value must never be exceeded.
- *Maximum repetitive reverse voltage* [ $V_{rm(rep)}$ ] — the maximum value of reverse voltage that can be applied recurrently (in every cycle of 60 Hz power). This includes oscillatory voltages that may appear on the sinusoidal supply.
- *Working peak reverse voltage* [ $V_{rm(wkg)}$ ] — the crest value of the sinusoidal voltage of the ac supply at its maximum limit. Rectifier manufacturers generally recommend a value that has a significant safety margin, relative to the peak transient reverse voltage ( $V_{rm}$ ), to allow for transient overvoltages on the supply lines.

There are three forward-current ratings of similar importance in the application of silicon rectifiers:

- *Nonrecurrent surge current* [ $I_{fm(surge)}$ ] — the maximum device transient current that must not be exceeded at any time.  $I_{fm(surge)}$  is sometimes given as a single value, but often is presented in the form of a graph of permissible surge-current values vs. time. Because silicon diodes have a relatively small thermal mass, the potential for short-term current overloads must be given careful consideration.
- *Repetitive peak forward current* [ $I_{fm(rep)}$ ] — the maximum value of forward current reached in each cycle of the 60 Hz waveform. This value does not include random peaks caused by transient disturbances.
- *Average forward current* [ $I_{fm(av)}$ ] — the upper limit for average load current through the device. This limit is always well below the repetitive peak forward-current rating to ensure an adequate margin of safety.

Rectifier manufacturers generally supply curves of the instantaneous forward voltage vs. instantaneous forward current at one or more specific operating temperatures. These curves establish the forward-mode upper operating parameters of the device.

Figure 7.1 shows a typical rectifier application in a bridge rectifier circuit.

### 7.2.1 Operating Rectifiers in Series

High-voltage power supplies (5 kV and greater) often require rectifier voltage ratings well beyond those typically available from the semiconductor industry. To meet the requirements of the application, manufacturers commonly use silicon diodes in a series configuration to yield the required working peak reverse voltage. For such a configuration to work properly, the voltage across any one diode must not exceed the

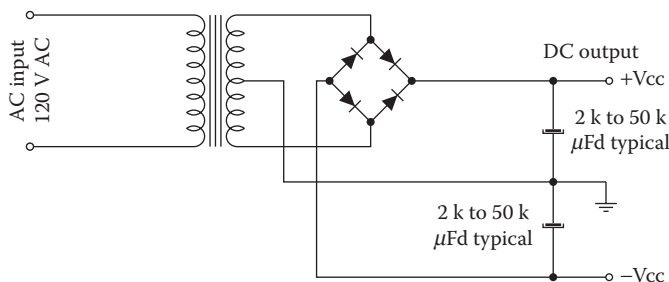


Figure 7.1 Conventional capacitor input filter full-wave bridge.

rated peak transient reverse voltage ( $V_{rm}$ ) at any time. The dissimilarity commonly found between the reverse leakage current characteristics of different diodes of the same type number makes this objective difficult to achieve. The problem normally is overcome by connecting shunt resistors across each rectifier in the chain, as shown in Figure 7.2. The resistors are chosen so that the current through the shunt elements (when the diodes are reverse-biased) will be several times greater than the leakage current of the diodes themselves.

The *carrier storage* effect also must be considered in the use of a series-connected rectifier stack. If precautions are not taken, different diode recovery times (caused by the carrier storage phenomenon) will effectively force the full applied reverse voltage across a small number of diodes, or even a single diode. This problem can be prevented by connecting small-value capacitors across each diode in the rectifier stack. The capacitors equalize the transient reverse voltages during the carrier storage recovery periods of the individual diodes.

Figure 7.3 illustrates a common circuit configuration for a high-voltage, three-phase rectifier bank. A photograph of a high-voltage, series-connected, three-phase rectifier assembly is shown in Figure 7.4.

### 7.2.2 Operating Rectifiers in Parallel

Silicon rectifiers are used in a parallel configuration when a large amount of current is required from the power supply. Parallel assemblies normally are found in low-voltage, high-current supplies. *Current sharing* is the major design problem with a parallel rectifier assembly because diodes of the same type number do not necessarily exhibit the same forward characteristics.

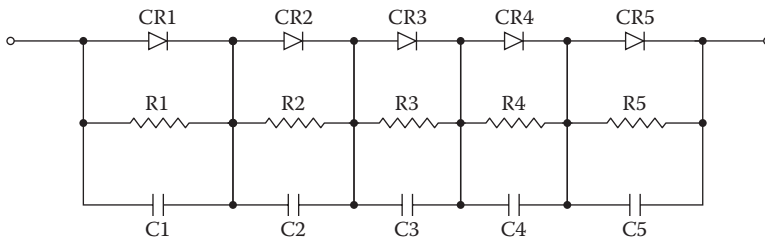


Figure 7.2 A portion of a high-voltage, series-connected rectifier stack.

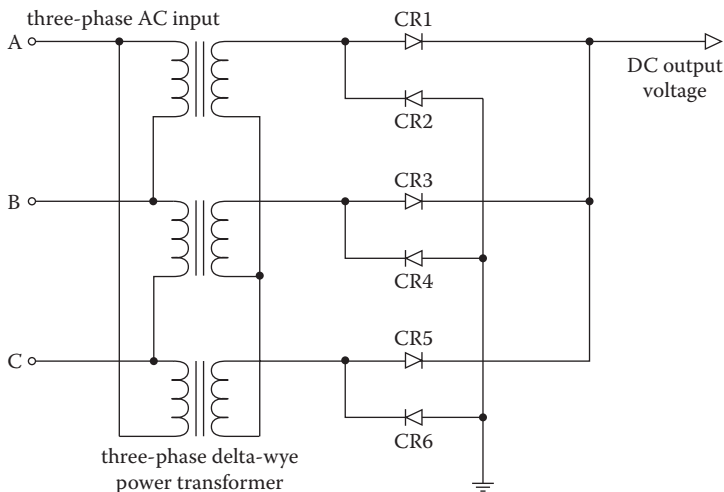
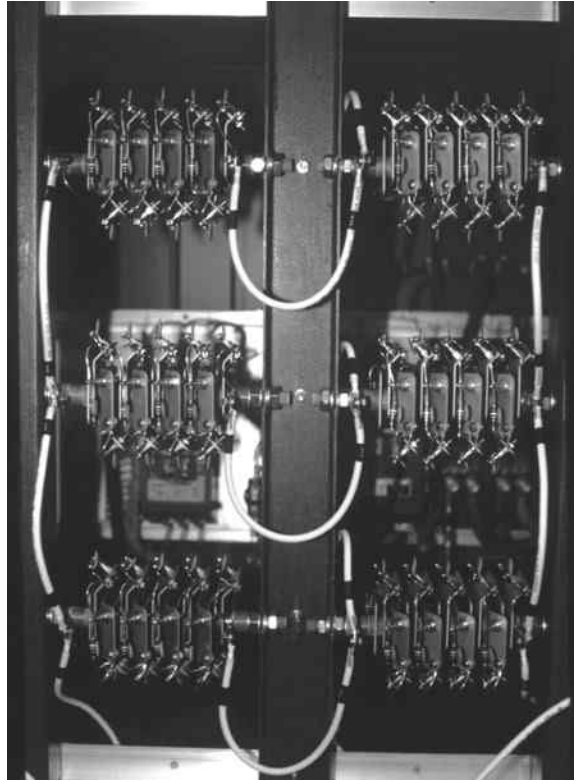


Figure 7.3 Three-phase, delta-connected high-voltage rectifier.



**Figure 7.4** High-voltage rectifier assembly for a three-phase, delta-connected circuit.

Semiconductor manufacturers often divide production runs of rectifiers into tolerance groups, matching forward characteristics of the various devices. When parallel diodes are used, devices from the same tolerance group must be selected to avoid unequal sharing of the load current. As a margin of safety, designers allow a substantial derating factor for devices in a parallel assembly to ensure that the maximum operating limits of any one component are not exceeded.

The problems inherent in a parallel rectifier assembly can be reduced through the use of a resistance or reactance in series with each component, as shown in [Figure 7.5](#). The build-out resistances ( $R_1$  through  $R_4$ ) force the diodes to share the load current equally. Such assemblies can, however, be difficult to construct and may be more expensive than simply adding diodes or going to higher-rated components. Power loss issues must also be considered with this approach.

### 7.2.3 Silicon Avalanche Rectifiers

The silicon avalanche diode is a special type of rectifier that can withstand high reverse power dissipation. For example, an avalanche diode with a normal forward rating of 10 A can dissipate a reverse transient of 8 kW for 10 ms without damage. This characteristic of the device allows elimination of the surge-absorption capacitor and voltage-dividing resistor networks needed when conventional silicon diodes are used in a series rectifier assembly. Because fewer diodes are needed for a given applied reverse voltage, significant underrating of the device (to allow for reverse voltage transient peaks) is not required.

When an extra-high-voltage rectifier stack is used, it is still advisable to install shunt capacitors — but not resistors — in an avalanche diode assembly. The capacitors are designed to compensate for the effects of carrier storage and stray capacitance in a long series assembly.

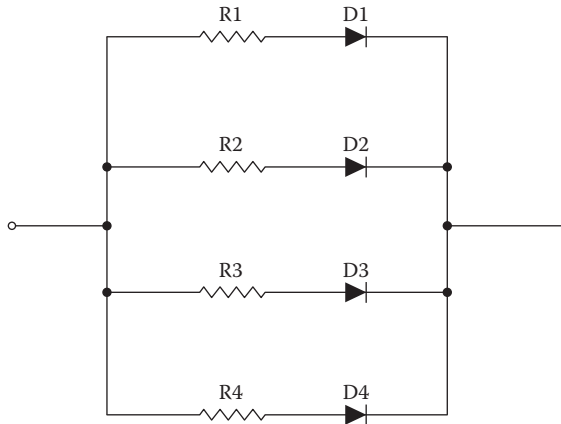


Figure 7.5 Using build-out resistances to force current sharing in a parallel rectifier assembly.

## 7.2.4 Single-Phase Rectifier Configurations

Rectifiers are one of the building blocks of ac power systems. Diodes are used to form rectifiers in electronic power supplies using one of four basic circuits:

- Half-wave
- Full-wave
- Bridge
- Voltage multiplier

### 7.2.4.1 Half-Wave Rectifier

The half-wave rectifier circuit is shown in Figure 7.6a [2]. When the input sinusoid voltage at *A* goes positive, the diode conducts, resulting in current in the load resistor *R*. When the input voltage goes negative, the diode becomes reverse-biased and, hence, does not conduct, resulting in negligible current across *R*. Therefore, the output voltage is given by

$$V_o = 0, \text{ if } V_i < V_{DO} \quad (7.1)$$

$$V_o = R / (R + r_D) V_i - V_{DO} R / (R + r_D) \quad (7.2)$$

where

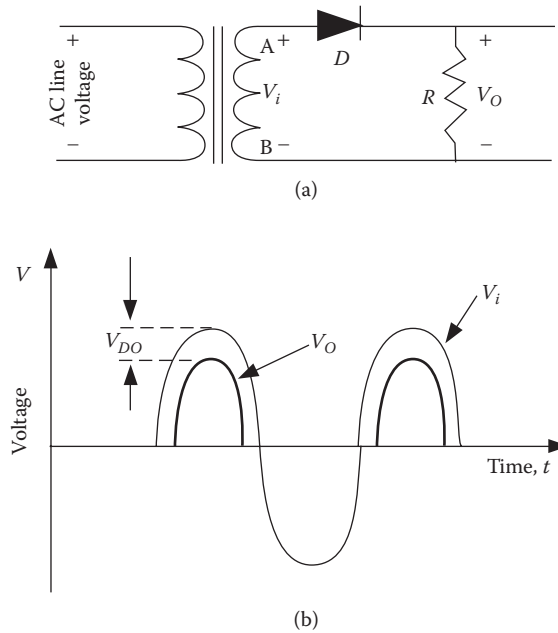
- $V_i$  = The input voltage
- $V_{DO}$  = Diode forward voltage  $\cong 0.7$  to  $0.8$  V
- $r_D$  = Diode resistance

Figure 7.6b shows the output voltage waveform for a sinusoidal input voltage. If  $R \gg r_D$ , then Equation 7.2 simplifies to

$$V_o \cong V_i - V_{DO} \quad (7.3)$$

The following general aspects must be considered when designing a half-wave diode power supply:

- The current- or power-handling capability of the diode.
- The peak inverse voltage (PIV) that the diode must be able to withstand without breakdown. When the input voltage goes negative, the diode becomes reverse-biased and the input voltage  $V_S$  appears across the diode.



**Figure 7.6** Half-wave rectifier circuit: (a) schematic diagram, (b) input and output waveforms. (From [2]. Used with permission.)

#### 7.2.4.2 Full-Wave Rectifier

The full-wave rectifier utilizes both halves of the input sinusoid [2]. One common implementation is shown in Figure 7.7a. The full-wave rectifier consists of two half-wave rectifiers connected to a load  $R$ . The secondary transformer winding is center tapped to provide two equal voltages  $V_i$  for each half-wave rectifier. When the node  $A$  is at positive polarity,  $V_i$  with respect to node  $B$ ,  $D_1$  will be forward-biased and  $D_2$  will be reverse-biased. Therefore, diode  $D_1$  will conduct and the current will flow through  $R$  back to the center tap of the transformer. When the node  $B$  is at positive polarity  $V_i$  with respect to node  $A$ ,  $D_2$  will be forward-biased and diode  $D_1$  will be reverse-biased. The current conducted by  $D_2$  will flow through  $R$  and back to center tap. The current through  $R$  is always in the same direction, giving rise to unipolar voltage  $V_O$  across  $R$ . The input and output voltage waveforms of the full-wave rectifier are shown in Figure 7.7b.

The output voltage of the full-wave rectifier is given by

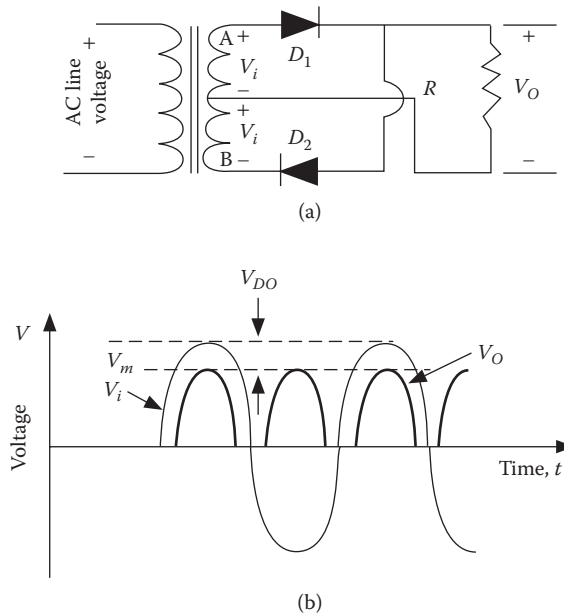
$$V_0 = \left[ \frac{R}{R_t + r_D + R} \right] (V_s - V_{D0}) \quad (7.4)$$

where  $R_t$  = resistance associated with the transformer. The dc value of the output voltage  $V_{dc}$  is

$$V_{dc} \cong 2 \left[ \frac{R}{R_t + r_D + R} \right] \frac{V_m}{\pi} \quad (7.5)$$

$$V_{dc} = \frac{2V_m}{\pi} \text{ if } R \gg R + r_D + r_t \quad (7.6)$$

where  $V_m$  = the peak output voltage.



**Figure 7.7** Full-wave rectifier circuit: (a) schematic diagram, (b) input and output waveforms. (From [2]. Used with permission.)

Thus, the full-wave rectifier produces double the output voltage of the half-wave rectifier. The ripple content  $r$  of the full-wave rectifier is given by

$$r = \left[ \frac{\pi^2}{8} - 1 \right]^{1/2} = 0.483 \tag{7.7}$$

The ripple factor for a full-wave rectifier is significantly less than that of a half-wave rectifier.

Another important element to be considered in the design of a full wave rectifier is the peak inverse voltage rating of the diodes. During the positive half-cycle, diode  $D_1$  is conducting and  $D_2$  is cut off. The voltage at the cathode of  $D_2$  will be at its maximum when  $V_O$  is at its peak value of  $(V_i - V_{D0})$  and  $V_i$  at its peak value. Therefore, the peak inverse voltage,  $PIV = 2V_i - V_{D0}$ , is approximately twice that of the half-wave rectifier.

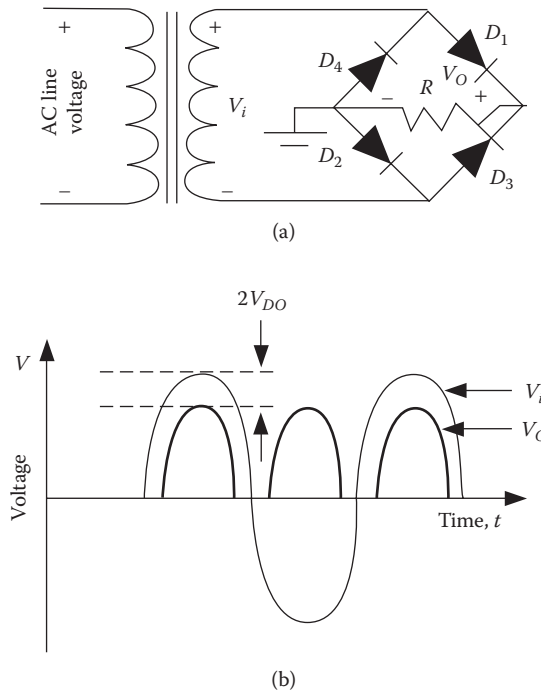
### 7.2.4.3 Bridge Rectifier

The full-wave rectifier requires a center-tapped transformer. The bridge rectifier is an alternative implementation of the full-wave circuit [2]. (See Figure 7.8a.) This rectifier uses four diodes and does not require a center-tapped transformer. Figure 7.8b shows the input and output voltage waveforms for the bridge rectifier. During the positive half cycles of the input voltage,  $V_i$  is positive and the current is conducted through diode  $D_1$ , resistor  $R$ , and diode  $D_2$ . Meanwhile, diodes  $D_3$  and  $D_4$  will be reverse-biased. During the positive half-cycle, because two diodes are conducting, the output voltage will be  $V_i - 2V_{D0}$ . During the negative half-cycle, the voltage  $V_i$  will be negative, and diodes  $D_3$  and  $D_4$  are forward-biased; the current through  $R$  follows the same direction as in the case of the positive half-cycle.

During positive half-cycle, the reverse voltage across  $D_3$  can be determined from the loop formed by  $D_3$ ,  $R$ , and  $D_2$  as

$$V_{D3} \text{ (reverse)} = V_O + V_{D2} \text{ (forward)} \tag{7.8}$$

The maximum value of  $V_{D3}$  occurs at the peak of  $V_O$  and is given by



**Figure 7.8** Bridge rectifier circuit: (a) schematic diagram, (b) input and output waveforms. (From [2]. Used with permission.)

$$PIV = V_i - 2V_{DO} + V_{DO} \quad (7.9)$$

$$PIV = V_i - V_{DO} \quad (7.10)$$

The PIV is about half the value for the full-wave rectifier with a center-tapped transformer, which is an advantage of the bridge rectifier.

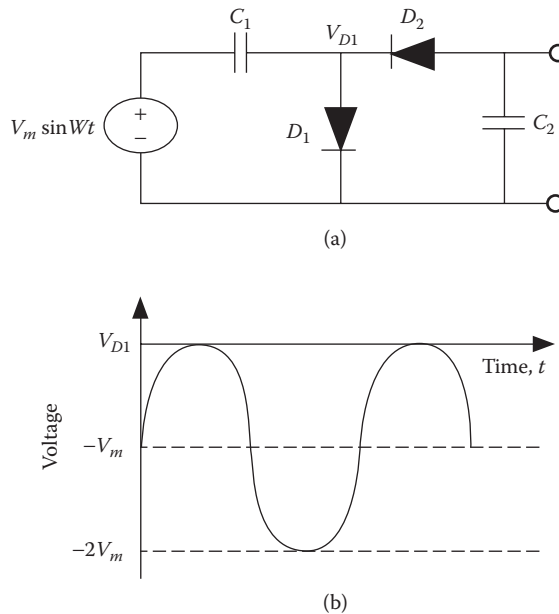
#### 7.2.4.4 Voltage Multiplier

The dc output voltage ( $V_{dc}$ ) in a rectifier circuit is limited by the peak value of the ac voltage applied ( $V_l$ ) [2]. Figure 7.9a shows the voltage doubler circuit composed of a *clamp* formed by  $C_1$  and  $D_1$  and a *peak rectifier* formed by  $D_2$  and  $C_2$ . When excited by a sinusoid of amplitude  $V_p$ , the output of the clamping section reaches the negative peak value of  $-2V_p$ , as shown in Figure 7.9b. By connecting additional diode-capacitor circuits, it is possible to generate rectifier circuits that triple and quadruple the input voltage.

### 7.2.5 Polyphase Rectifier Circuits

High-voltage power supplies typically used in vacuum tube circuits incorporate multiphase rectification of the ac line voltage. Common configurations include 3-, 6-, and 12-phase. Three-phase rectification is the most common. Figure 7.10 illustrates four approaches to three-phase rectification:

- *Three-phase half-wave wye*, Figure 7.10a. Three half-wave rectifiers are used in each leg of the secondary  $Y$ , forming one phase. In such an arrangement, each diode carries current one third of each cycle, and the output wave pulses at three times the frequency of the ac supply. In order to avoid direct-current saturation in the transformer, it is necessary to employ a three-phase transformer rather than three single-phase transformers.



**Figure 7.9** Voltage doubler circuit: (a) schematic diagram, (b) input and output waveforms. (From [2]. Used with permission.)

- *Three-phase full-wave bridge*, Figure 7.10b. Six diodes are used in this circuit to produce a low ripple output with a frequency of 6 times the input ac waveform. It is permissible in this configuration to use three single-phase transformers, if desired.
- *Six-phase star*, Figure 7.10c. This circuit, also known as a *three-phase diametric* configuration, uses six diodes with a transformer secondary configured as a star, as illustrated in the figure. The output ripple frequency is six times the input ac waveform.
- *Three-phase double-ye*, Figure 7.10d. This circuit uses six diodes and a complicated configuration of transformer windings. Note the balance coil (*interphase transformer*) in the circuit.

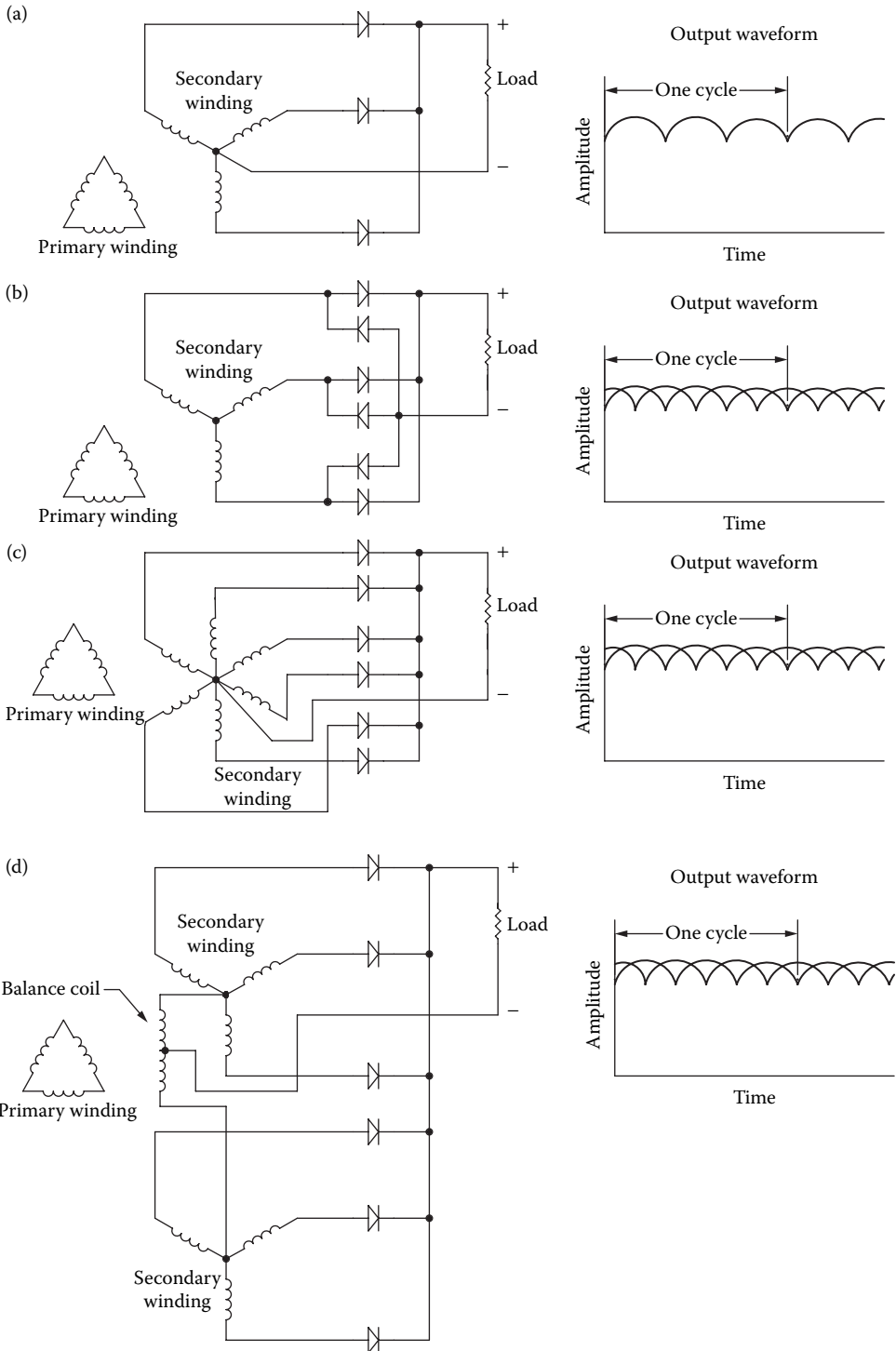
The relative merits of these rectifier configurations are listed in Table 7.2.

Polyphase rectifiers are used when the dc power required is on the order of 2 kW or more. The main advantages of a polyphase power supply over a single-phase supply include the following:

- Division of the load current between three or more lines to reduce line losses.
- Significantly reduced filtering requirements after rectification because of the low ripple output of a polyphase rectifier.
- Improved voltage regulation when using an inductive-input filter. Output voltage *soaring* is typically 6% or less from full load to no load conditions.
- Greater choice of output voltages from a given transformer by selection of either a delta or wye configuration.

The main disadvantage of a polyphase system is its susceptibility to phase imbalance. Resulting operational problems include increased ripple at the output of the supply and uneven sharing of the load current by the transformer windings.





**Figure 7.10** Basic three-phase rectifier circuits: (a) half-wave wye, (b) full-wave bridge, (c) six-phase star, (d) three-phase double-wye.

**Table 7.2** Operating Parameters of Three-Phase Rectifier Configurations

Parameter	Three-Phase	Three-Phase	Six-Phase	Three-Phase	Multiplier <sup>1</sup>
	Star	Bridge	Star	Double-Wye	
Rectifier elements	3	6	6	6	
rms dc output	1.02	1.00	1.00	1.00	Average dc output
Peak dc output	1.21	1.05	1.05	1.05	Average dc output
Peak reverse volts per rectifier	2.09	1.05	2.09	2.42	Average dc output
output	2.45	2.45	2.83	2.83	rms secondary volts per transformer leg
Average dc output current per rectifier	1.41	1.41	1.41	1.41	rms secondary volts line-to-line
rms current per rectifier, resistive load	0.333	0.333	0.167	0.167	Average dc output current
rms current per rectifier, inductive load	0.587	0.579	0.409	0.293	Average dc output current
Percent ripple	0.578	0.578	0.408	0.289	Average dc output current
Ripple frequency	18.3	4.2	4.2	4.2	—
ac line power factor	3	6	6	6	Line frequency
Transformer secondary rms volts per leg <sup>2</sup>	0.826	0.955	0.955	0.955	—
Transformer secondary rms volts line-to-line	0.855	0.428	0.740	0.855	Average dc voltage output
Secondary line current	1.48	0.740	1.48 (max)	1.71 (max)	Average dc voltage output no load
Transformer secondary VA	0.578	0.816	0.408	0.299	Average dc output current
Primary line current	1.48	1.05	1.81	1.48	dc watts output
	0.817	1.41	0.817	0.707	(Avg. load I × secondary leg V) ÷ primary line V

<sup>1</sup> To determine the value of a parameter in any column, multiply the factor shown by the value given in this column.

<sup>2</sup> For inductive load or large choke input filter.

## 7.3 Power Supply Filter Circuits

A filter network for a high-voltage power supply typically consists of a series inductance and one or more shunt capacitances [3]. Bleeder resistors are also usually incorporated. Filter systems can be divided into two basic types:

- *Inductive input*, filter circuits that present a series inductance to the rectifier output.
- *Capacitive input*, filter circuits that present a shunt capacitance to the rectifier output.

### 7.3.1 Inductive Input Filter

An inductive input filter is shown in Figure 7.11, along with typical current waveforms [3]. When the input inductance is infinite, current through the inductance is constant and is carried at any moment by the rectifier anode that has the most positive voltage applied to it at that instant. As the alternating voltage being rectified passes through zero, the current suddenly transfers from one anode to another, producing square current waves through the individual rectifier devices.

When the input inductance is finite (but not too small), the situation changes to that shown by the solid lines of Figure 7.11. The current through the input inductance tends to increase when the output voltage of the rectifier exceeds the average or dc current value, and to decrease when the rectifier output voltage is less than the dc value. This causes the current through the individual anodes to be modified as shown. If the input inductance is too small, the current decreases to zero during a portion of the time between the peaks of the rectifier output voltage, and the conditions then correspond to a capacitor input filter system.

The output wave of the rectifier can be considered as consisting of a dc component upon which are superimposed ac voltages (*ripple voltages*). To a first approximation, the fluctuation in output current resulting from a finite input inductance can be considered as the current resulting from the lowest frequency component of the ripple voltage acting against the impedance of the input inductance. This assumption is permissible because the higher frequency components in the ripple voltage are smaller and at the same time encounter higher impedance. Furthermore, in practical filters, the shunting capacitor

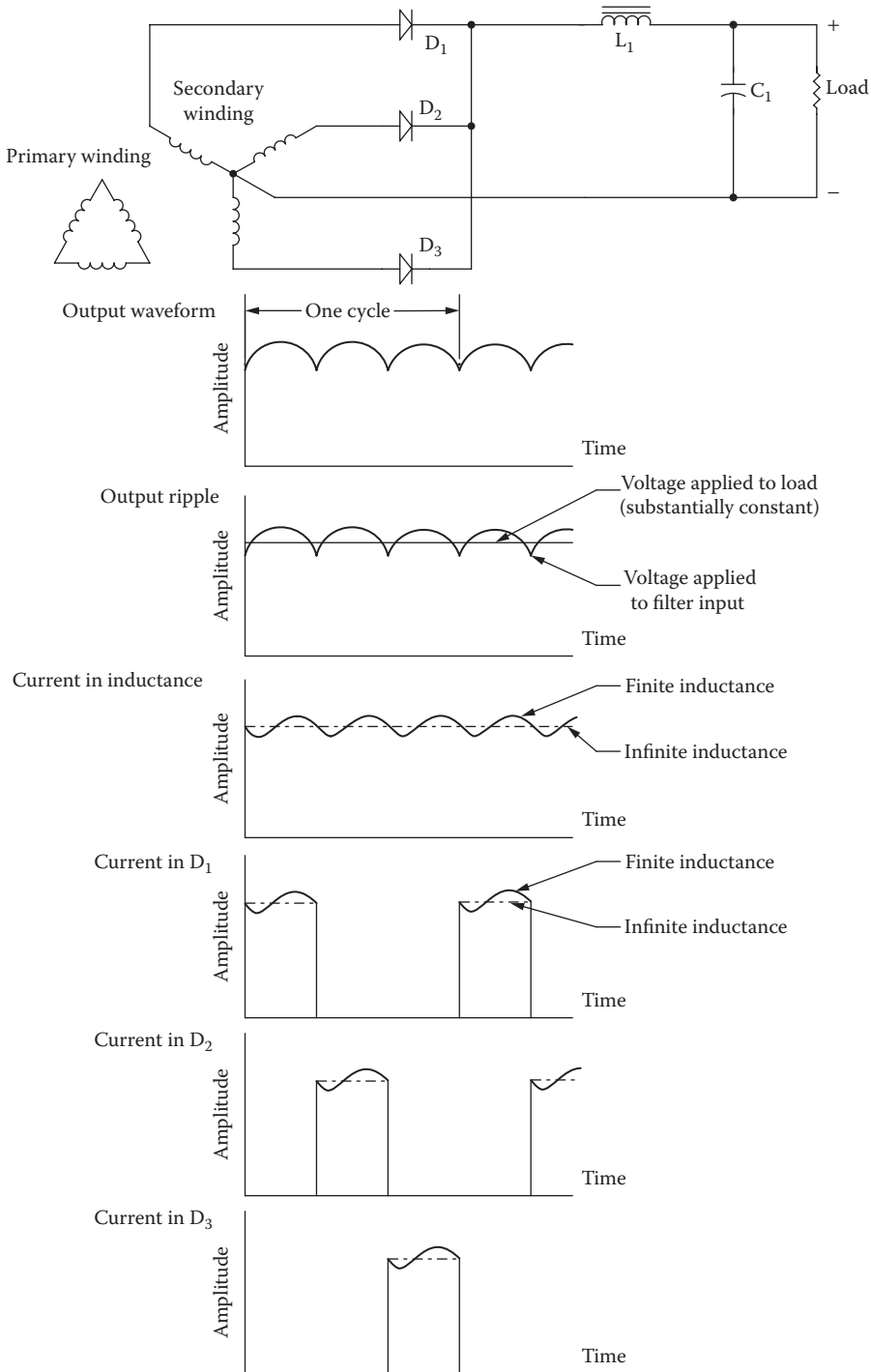


Figure 7.11 Voltage and current waveshapes for an inductive input filter driven by a three-phase supply.

following the input inductance has a small impedance at the ripple frequency compared with the reactance of the input inductance. The peak current resulting from a finite input inductance is, therefore, given approximately by the relation:

$$\frac{I_f}{I_i} = 1 + \frac{E_1 R_{eff}}{E_0 \omega L_1} \quad (7.11)$$

where

- $I_f$  = Peak current with finite input inductance
- $I_i$  = Peak current with infinite input inductance
- $E_1/E_0$  = Ratio of lowest frequency ripple component to the dc voltage in the rectifier output
- $R_{eff}$  = Effective load resistance
- $\omega L_1$  = Reactance of the incremental value of the input inductance at the lowest ripple frequency

This equation is derived as follows:

- The peak alternating current through the input inductance is approximately  $E_1/\omega L_1$ .
- The average or dc current is  $E_0/R_{eff}$ .
- The peak current with finite inductance is, therefore,  $(E_1/\omega L_1) + (E_0/R_{eff})$ .
- The current with infinite inductance is  $E_0/R_{eff}$ .
- The effective load resistance value consists of the actual load resistance plus filter resistance plus equivalent diode and transformer resistances.

The normal operation of an inductive input filter requires that there be a continuous flow of current through the input inductance. The peak alternating current flowing through the input inductance must, therefore, be less than the dc output current of the rectifier. This condition is realized by satisfying the approximate relation

$$\omega L_1 = R_{eff} \frac{E_1}{E_0} \quad (7.12)$$

In the practical case of a 60 Hz single-phase, full-wave rectifier circuit, the foregoing equation becomes

$$L_1 = \frac{L_{eff}}{1130} \quad (7.13)$$

In a polyphase system, the required value of  $L_1$  is significantly less. The higher the load resistance (the lower the dc load current), the more difficult it is to maintain a continuous flow of current, and with a given  $L_1$ , the previous equation will not be satisfied when the load resistance exceeds a critical value.

The minimum allowable input inductance ( $\omega L_1$ ) is termed the *critical inductance*. When the inductance is less than the critical value, the filter acts as a capacitor input circuit. When the dc drawn from the rectifiers varies, it is still necessary to satisfy the  $\omega L_1$  equation at all times, particularly if good voltage regulation is to be maintained. To accomplish this requirement at small load currents without excessive inductance, it is necessary to place a bleeder resistance across the output of the filter system in order to limit  $R_{eff}$  to a value corresponding to a reasonable value of  $L_1$ .

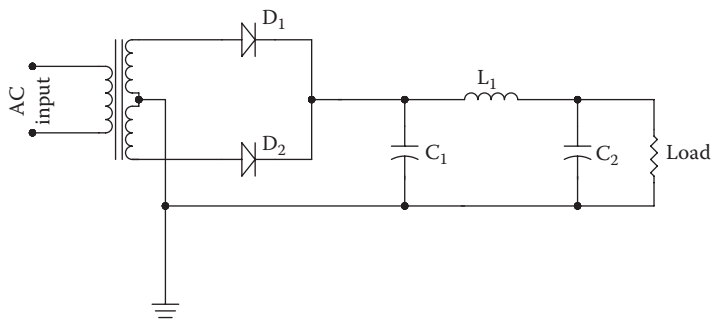
### 7.3.2 Capacitive Input Filter

When a shunt capacitance rather than a series inductance is presented to the output of a rectifier, the behavior of the circuit is greatly modified [3]. Each time the positive crest alternating voltage of the transformer is applied to one of the rectifier anodes, the input capacitor charges up to just slightly less than

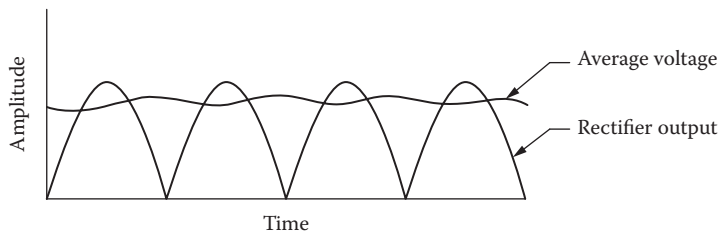
this peak voltage. The rectifier then ceases to deliver current to the filter until another anode approaches its peak positive potential, when the capacitor is charged again. During the interval when the voltage across the input capacitor is greater than the potential of any of the anodes, the voltage across the input capacitor drops off nearly linearly with time, because the first filter inductance draws a substantially constant current from the input capacitor. A typical set of voltage and current waves is illustrated in Figure 7.12.

The addition of a shunt capacitor to the input of a filter thus produces fundamental changes in behavior, including:

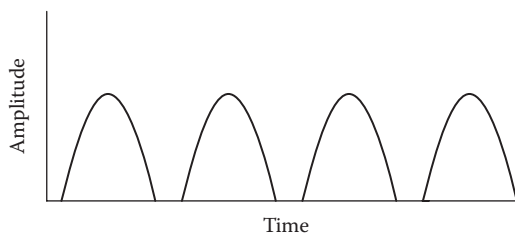
- The output voltage is appreciably higher than with an inductance input.
- The ripple voltage is lower with a capacitive input filter than an inductive input filter.
- The dc voltage across the filter input drops as the load current increases for the capacitive-input case, instead of being substantially constant, as for the inductive input case.
- The ratio of peak-to-average anode current at the rectifiers is higher in the capacitive case.
- The utilization factor of the transformer is lower with a capacitive input configuration.



(a)



(b)



(c)

**Figure 7.12** Characteristics of a capacitive input filter circuit: (a) schematic diagram, (b) voltage waveshape across input capacitor, (c) waveshape of current flowing through diode.

Filters incorporating shunt capacitor inputs are generally employed when the amount of dc power required is small. Inductance input filters are used when the amount of power involved is large; the higher utilization factor and lower peak current result in important savings in rectifier and transformer costs under these conditions. Inductance input systems are almost universally employed in polyphase rectifier applications.

## 7.4 References

---

1. Nenoff, L., "Effect of EMP Hardening on System R&M Parameters," *Proceedings, 1986 Reliability and Maintainability Symposium*, IEEE, New York, 1986.
2. Kalkur, T. S., "Rectifier and Filter Circuits," in *The Electronics Handbook*, J. C. Whitaker, (Ed.), CRC Press, Boca Raton, FL, pp. 938–943, 1996.
3. Terman, F. E., *Radio Engineering*, McGraw-Hill, New York, 1947.

## 7.5 Bibliography

---

- Fink, D., and D. Christiansen (Eds.), *Electronics Engineers' Handbook*, 3<sup>rd</sup> ed., McGraw-Hill, New York, 1989.
- Jordan, Edward C. (Ed.), *Reference Data for Engineers: Radio, Electronics, Computer, and Communications*, 7<sup>th</sup> ed., Howard W. Sams Company, Indianapolis, 1985.

## 8.1 Introduction

---

The modern age of power electronics began with the introduction of thyristors in the late 1950s [1]. There are now a number of power devices available for high-power and high-frequency applications. The most notable include:

- *Gate turn-off* (GTO) thyristor
- Power Darlington transistor
- Power MOSFET
- *Insulated-gate bipolar transistor* (IGBT)

These power devices are used primarily as switches to convert energy from one form to another. They are used in motor control systems, uninterruptible power supplies, high-voltage dc transmission, ac-to-dc power supplies, induction heating, and other power-conversion applications.

## 8.2 Thyristor Devices

---

The thyristor, also called a *silicon-controlled rectifier* (SCR), is basically a four-layer three-junction pnpn device [1]. It has three terminals: anode, cathode, and gate. The device is turned on by applying a short pulse across the gate and cathode. After the device turns on, the gate loses its control to turn off the device. The turn-off is achieved, instead, by applying a reverse voltage across the anode and cathode. The thyristor volt-ampere characteristics are shown in [Figure 8.1](#).

There are basically two classifications of thyristors: *converter grade* and *inverter grade*. The difference between a converter-grade and an inverter-grade thyristor is the low turn-off time (on the order of a few microseconds) for the latter. Converter-grade thyristors are slower and are used in *natural commutation* (or phase-controlled) applications. Inverter-grade thyristors are used in *forced commutation* applications such as dc-dc choppers and dc-ac inverters. Inverter-grade thyristors are turned off by forcing the current to zero using an external commutation circuit. This requires additional commutating components, thus resulting in additional losses in the inverter.

Thyristors are rugged devices in terms of transient currents ( $di/dt$  and  $dv/dt$  capability). The forward voltage drop in a thyristor typically is about 1.5 to 2 V; even at high currents on the order of 500 A, it seldom exceeds 3 V. Although the forward voltage determines the on-state power loss of the device at any given current, the switching power loss becomes a dominating factor affecting the device junction temperature at high operating frequencies. Thus, the maximum switching frequencies possible using thyristors are limited in comparison with many other power devices. Thyristors are commonly available at ratings of up to 6000 V, 3500 A.

A *triac* is functionally a pair of converter-grade thyristors connected in an antiparallel arrangement. The triac volt-ampere characteristics are shown in [Figure 8.2](#). Because of the physical integration of the device, the triac has poor reapplied  $dv/dt$  capability, poor gate current sensitivity at turn-on, and a longer turn-off time, relative to a pair of equivalent-rating thyristors. Triacs are mainly used in phase control applications such as ac regulators for lighting and fan control, and in solid-state ac relays.

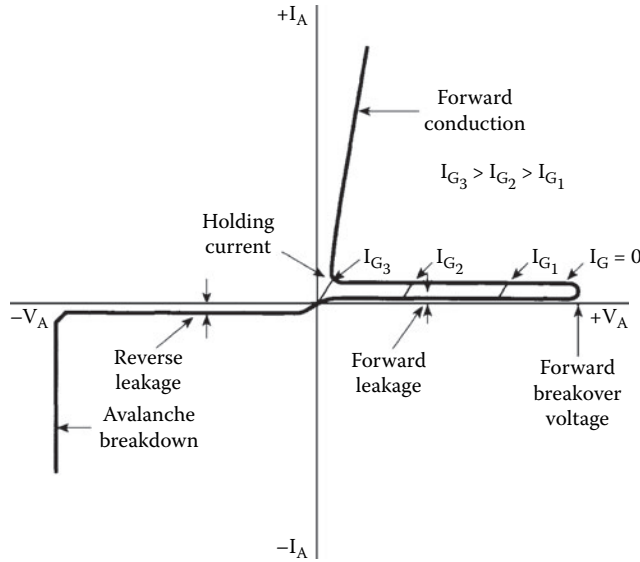


Figure 8.1 Voltampere characteristics of a thyristor. (After [1] and [2].)

8.2.1 Thyristor Servo Systems

Thyristor control of ac power has become a popular method of switching and regulating high-voltage or high-current power supplies. The type of servo system employed depends on the application. Figure 8.3 shows a basic single-phase ac control circuit using discrete thyristors. The rms load current ( $I_{rms}$ ) at any specific phase delay angle ( $\theta$ ) is given in terms of the normal full-load rms current at a phase delay of zero ( $I_{rms-0}$ ):

$$I_{rms} = I_{rms-0} \left[ 1 - \frac{\alpha}{\pi} + (2\pi)^{-1} \sin 2\pi \right] \frac{1}{2} \quad (8.1)$$

The load rms voltage at any particular phase-delay angle bears the same relationship to the full-load rms voltage at zero phase delay as the previous equation illustrates for load current. An analysis of the mathematics shows that although the theoretical delay range for complete control of a resistive load is 0 to 180°, a practical span of 20 to 160° gives a power-control range of approximately 99% to 1% of maximum output to the load. Figure 8.4 illustrates typical phase-control waveforms.

The circuit shown in Figure 8.3 requires a source of gate trigger pulses that must be isolated from each other by at least the peak value of the applied ac voltage. The two gate pulse trains must also be phased 180° with respect to each other. Furthermore, the gate pulse trains must shift together with respect to the ac supply voltage phase when power throughput is adjusted.

Some power-control systems use two identical, but isolated, gate pulse trains operating at a frequency of twice the applied supply voltage (120 Hz for a 60 Hz system). Under such an arrangement, the forward-biased thyristor will fire when the gate pulses are applied to the SCR pair. The reverse-biased thyristor will not fire. Normally, it is considered unsafe to drive a thyristor gate positive while its

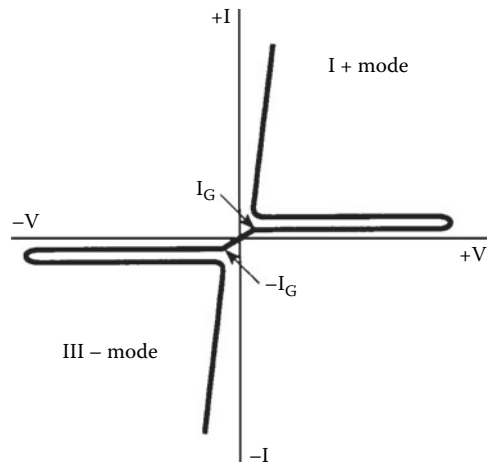
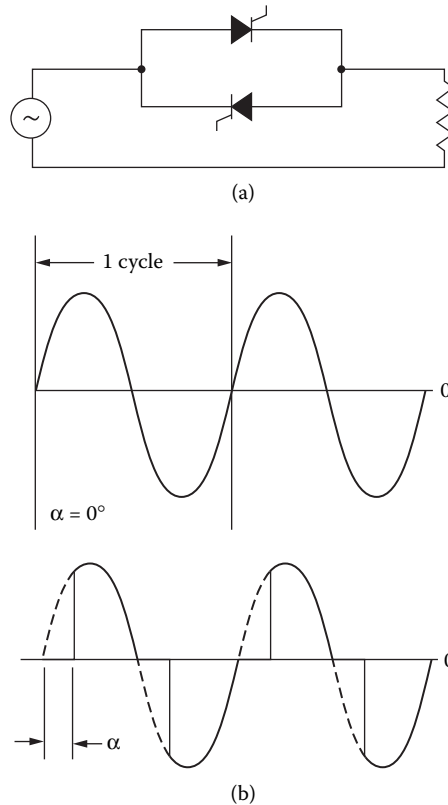


Figure 8.2 Voltampere characteristics of a triac. (After [1] and [2].)





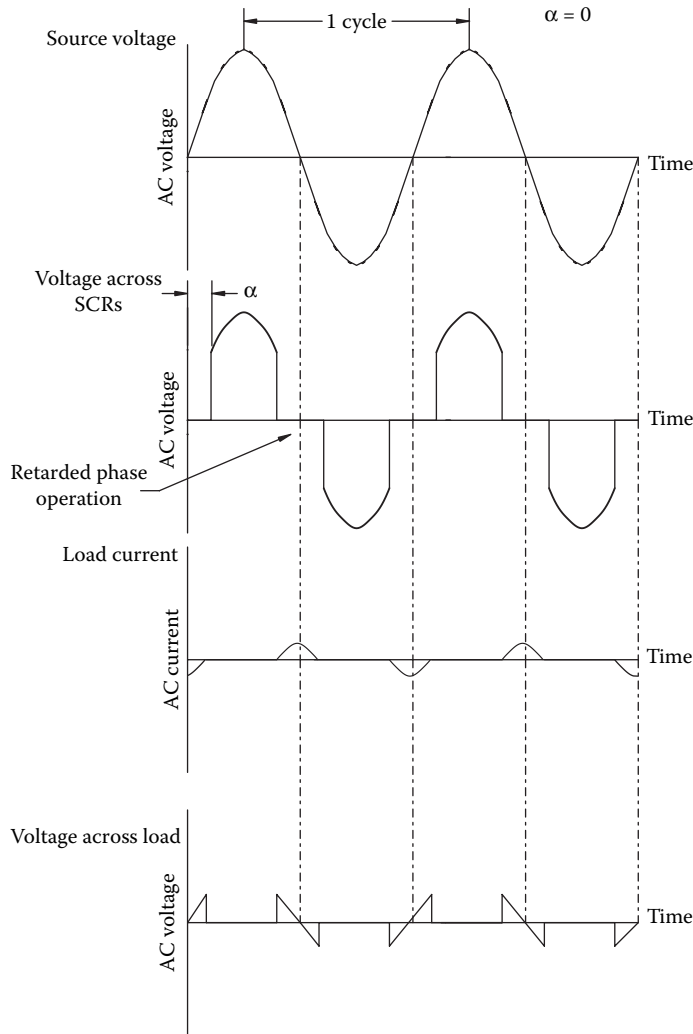
**Figure 8.3** Inverse-parallel thyristor ac power control: (a) circuit diagram; (b) voltage and current waveforms for full and reduced thyristor control angles. The waveforms apply for a purely resistive load.

anode-cathode is reverse-biased. In this case, however, it may be permissible because the thyristor that is fired immediately conducts and removes the reverse voltage from the other device. The gate of the reverse-biased device is then being triggered on a thyristor that essentially has no applied voltage.

### 8.2.1.1 Inductive Loads

The waveforms shown in [Figure 8.5](#) illustrate effects of phase control on an inductive load. When inductive loads are driven at a reduced conduction angle, a sharp transient change of load voltage occurs at the end of each current pulse (or loop). The transients generally have no effect on the load, but they can be dangerous to proper operation of the thyristors. When the conducting thyristor turns off, thereby disconnecting the load from the ac line supply, the voltage at the load rapidly drops to zero. This rapid voltage change, in effect, applies a sharply rising positive anode voltage to the thyristor opposing the device that has been conducting. If the thyristor  $dv/dt$  rating is exceeded, the opposing device will turn on and conduction will take place, independent of any gate drive pulse.

A common protective approach involves the addition of a resistor-capacitor ( $RC$ ) snubber circuit to control the rate of voltage change seen across the terminals of the thyristor pair. (See [Figure 8.6](#).) Whenever a thyristor pair is used to drive an inductive load, such as a power transformer, it is critically important that each device fires at a point in the applied waveform exactly  $180^\circ$  relative to the other. If proper timing is not achieved, the positive and negative current loops will differ in magnitude, causing a dc current to flow through the primary side of the transformer. A common trigger control circuit should, therefore, be used to determine gate timing for thyristor pairs.

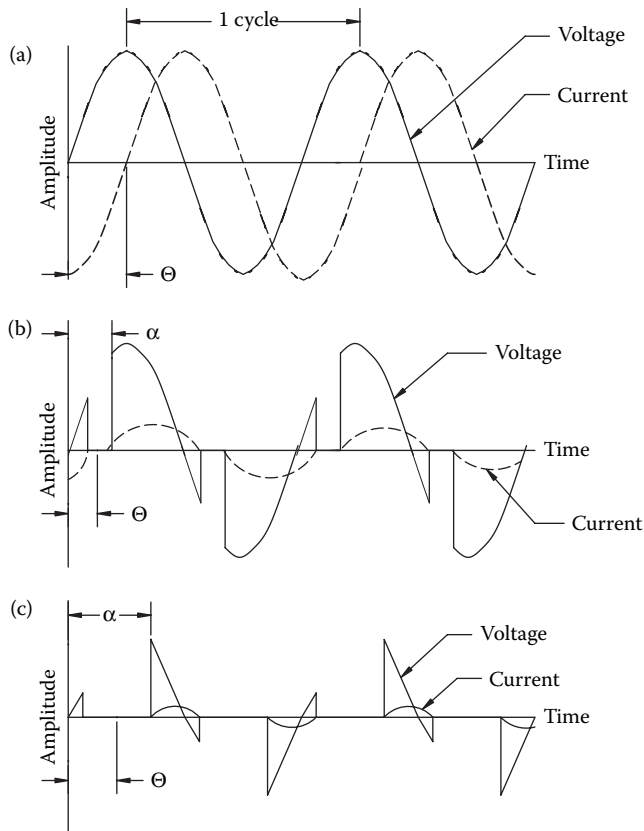


**Figure 8.4** Waveforms in an ac circuit using thyristor power control.

### 8.2.1.2 Applications

Several approaches are possible for thyristor power control in a three-phase ac system. The circuit shown in [Figure 8.7](#) consists of essentially three independent, but interlocked, single-phase thyristor controllers. This circuit is probably the most common configuration found in industrial equipment.

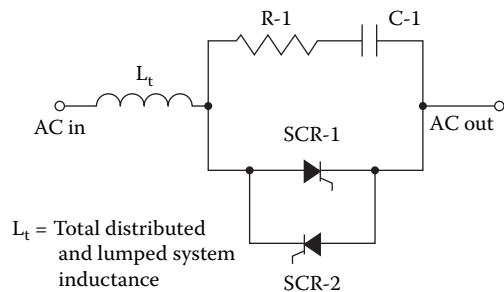
In a typical application, the thyristor pairs feed a power transformer with multitap primary windings, thereby giving the user an adjustment range to compensate for variations in utility company line voltages from one location to another. A common procedure specifies selection of transformer tap positions that yield a power output of 105% when nominal utility company line voltages are present. The thyristor power-control system then is used to reduce the angle of conduction of the SCR pairs as necessary to cause a reduction in line voltage to the power transformer to yield 100% rated power output from the power supply. A servo loop from a sample point at the load can be used to automatically compensate for line-voltage variations. With such an arrangement, the thyristors are kept within a reasonable degree of retarded-phase operation. Line voltages will be allowed to sag 5% or so without affecting the dc supply output. Utility supply voltage excursions above nominal value simply will result in delayed triggering of the SCR pairs.



**Figure 8.5** Voltage and current waveforms for inverse-parallel thyristor power control with an inductive load: (a) full conduction; (b) small-angle phase reduction; (c) large-angle phase reduction.

The effect of varying the conduction phase angle of a thyristor on the load current is illustrated in [Figure 8.8](#). Note how the current  $I_{avg}$  decreases as the conduction angle is reduced from  $180^\circ$ .

Thyristor control of high-power loads (200 kW and above) typically uses special transformers that provide 6- or 12-phase outputs. Although they are more complicated and expensive, such designs allow additional operational control, and filtering requirements are reduced significantly. [Figure 8.9](#) shows a six-phase *boost rectifier* circuit. The configuration consists basically of a full-wave, three-phase SCR bridge connected to a wye-configured transformer secondary. A second bridge, consisting of six diodes, is connected to low-voltage taps on the same transformer. When the SCRs are fully on, their output is at a higher voltage than the diode bridge. As a result, the diodes are reverse-biased and turned off. When the SCRs are partially on, the diodes are free to conduct. The diodes improve the quality of the output waveform during low-voltage (reduced conduction angle) conditions. The minimum output level of the supply is determined by the transformer taps to which the diodes are connected.



**Figure 8.6** Protective RC snubber for a thyristor-based power controller.

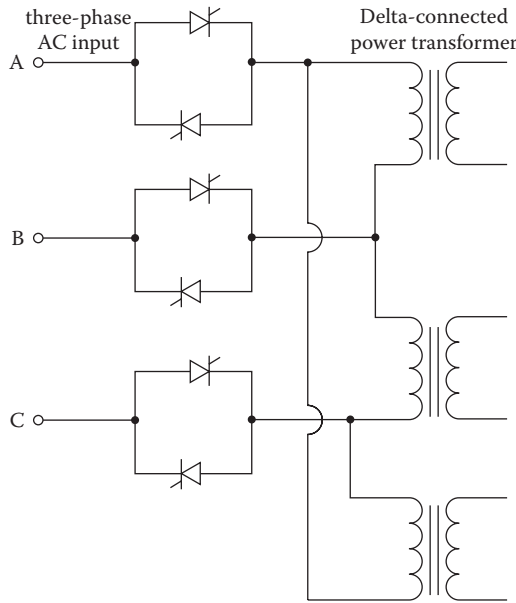


Figure 8.7 Modified full-thyristor three-phase ac control of an inductive delta load.

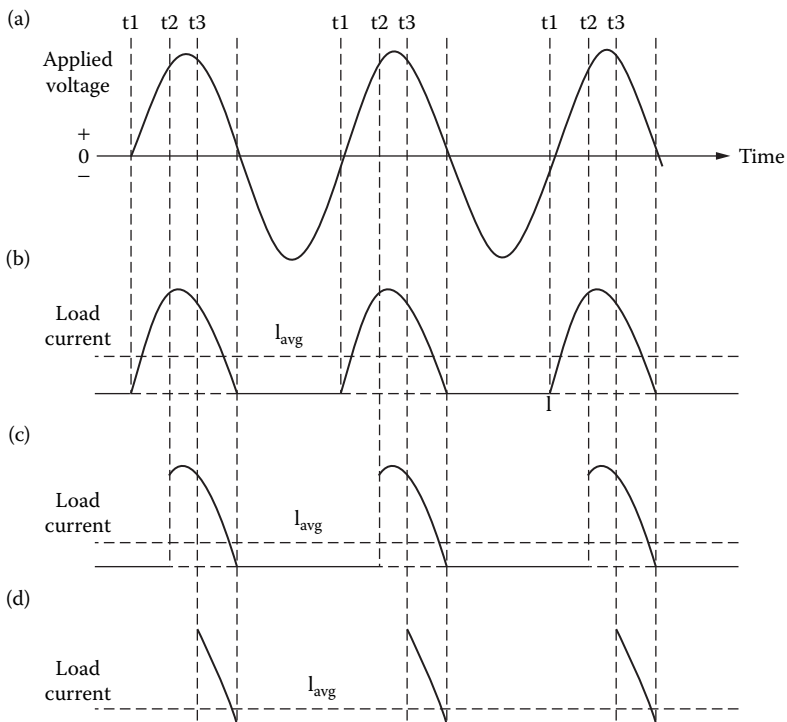


Figure 8.8 The effect of varying the phase angle of a thyristor on the load current  $I_{avg}$ : (a) applied voltage, (b) thyristor switched on at the zero crossing, (c) thyristor switched on at approximately  $60^\circ$  after the zero crossing, (d) thyristor switched on at approximately  $90^\circ$  after the zero crossing.

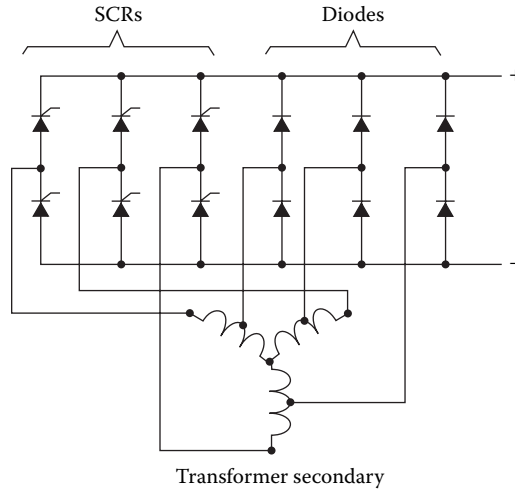


Figure 8.9 Six-phase boost rectifier circuit.

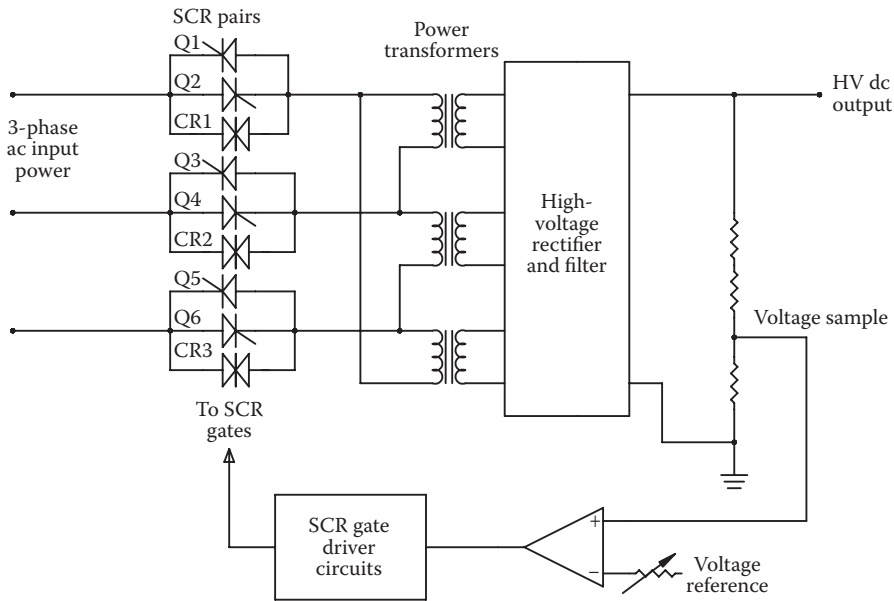


Figure 8.10 Thyristor-controlled high-voltage servo power supply.

A thyristor-driven, three-phase power-control circuit is shown in Figure 8.10. A single-phase power-control circuit is shown in Figure 8.11.

### 8.2.1.3 Triggering Circuits

Accurate, synchronized triggering of the gate pulses is a critical element in thyristor control of a three-phase power supply. The gate signal must be synchronized properly with the phase of the ac line that it is controlling. The pulse also must properly match the phase angle delay of the gates of other thyristors in the power-control system. Lack of proper synchronization of gate pulse signals between thyristor pairs can result in improper current sharing (current hogging) among individual legs of the three-phase supply.

The gate circuit must be protected against electrical disturbances that could make proper operation of the power-control system difficult or unreliable. Electrical isolation of the gate is a common approach.

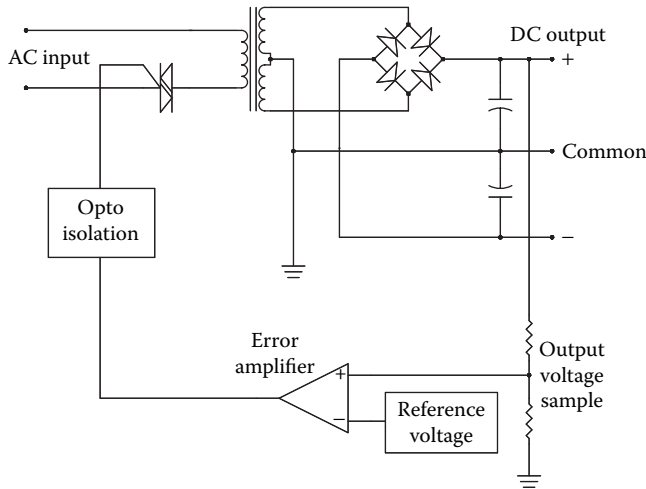


Figure 8.11 Phase-controlled power supply with primary regulation.

Standard practice calls for the use of gate pulse transformers in thyristor servo system gating cards. Pulse transformers are ferrite-cored devices with a single primary winding and (usually) multiple secondary windings that feed, or at least control, the individual gates of a back-to-back thyristor pair. This concept is illustrated in Figure 8.12. Newer thyristor designs may use optocouplers (primarily for low-power systems) to achieve the necessary electrical isolation between the trigger circuit and the gate.

It is common practice to tightly twist together the leads from the gate and cathode of a thyristor to the gating card assembly. This practice provides a degree of immunity to high-energy pulses that might inadvertently trigger the thyristor gate. The gate circuit must be designed and configured carefully to reduce inductive and capacitive coupling that might occur between power and control circuits. Because of the high di/dt conditions commonly found in thyristor-controlled power circuits, power wiring and control (gate) wiring must be separated physically as much as possible. Shielding of gating cards in metal card cages is advisable.

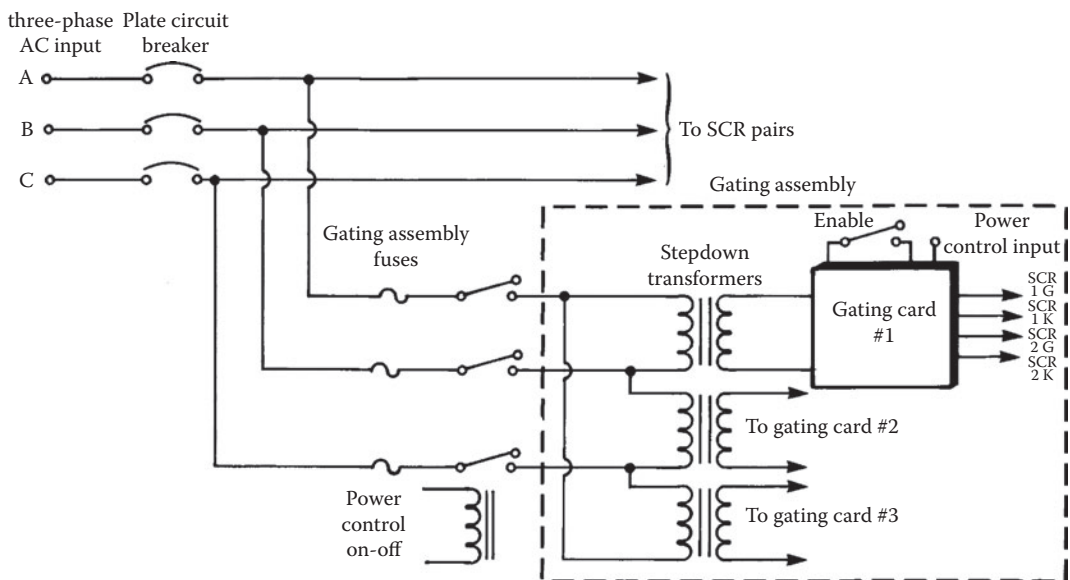


Figure 8.12 Simplified block diagram of the gating circuit for a phase-control system using back-to-back SCRs.

Equipment manufacturers use various means to decrease gate sensitivity to transient sources, including placement of a series resistor in the gate circuit or a shunting capacitor between the gate and cathode. A series resistor has the effect of decreasing gate sensitivity, increasing the allowable  $dv/dt$  of the thyristor, and reducing the turn-off time, which simultaneously increases the required holding and latching currents. The use of a shunt capacitor between the gate and cathode leads reduces high-frequency noise components that might be present on the gate lead and increases the  $dv/dt$  withstand capability of the thyristor. The application of these techniques is the exclusive domain of the design engineer. Users should not consider modifying a design without detailed consultation with the engineering department of the original equipment manufacturer.

#### 8.2.1.4 Control Flexibility

Thyristor servo control of a high-voltage or high-current power supply is beneficial to the user for a number of reasons. First is the wide control over ac input voltages that such systems provide. A by-product of this feature is the capability to compensate automatically for line-voltage variations. Other benefits include the capability to soft-start the dc supply. Thyristor control circuits typically include a ramp generator that increases the ac line voltage to the power transformer from zero to full value within 2 to 5 s. This prevents high-surge currents through rectifier stacks and filter capacitors during system startup.

Although thyristor servo systems are preferred over other power-control approaches from an operational standpoint, they are not without their drawbacks. The control system is complex and can be damaged by transient activity on the ac power line. Conventional power contactors are simple and straightforward. They either make contact or they do not. For reliable operation of the thyristor servo system, attention must be given to transient suppression at the incoming power lines.

### 8.2.2 Gate Turn-Off Thyristor

The GTO is a power switching device that can be turned on by a short pulse of gate current and turned off by a reverse gate pulse [1]. The required reverse gate current amplitude is dependent on the anode current to be turned off. Hence, there is no need for an external commutation circuit to turn off the device. Because turn-off is provided by bypassing carriers directly to the gate circuit, the turn-off time is short, thus making the device well suited for high-frequency operation. The GTO turn-off characteristics are shown in Figure 8.13.

For reliable operation, the critical aspects are proper design of the gate turn-off circuit and the snubber circuit. The GTO has poor turn-off current gain, on the order of 4 to 5. For example, a 2000 A peak current GTO may require as high as 500 A of reverse gate current. Also, the GTO has a tendency to latch at high temperatures (above approximately 125°C). GTO devices are commonly available for operation up to 4500 V at 2500 A.

### 8.2.3 Reverse-Conducting Thyristor

In typical inverter applications, a diode in antiparallel is connected to the thyristor for commutation/freewheeling purposes. In a *reverse-conducting thyristor* (RCT), the diode is integrated with a fast switching thyristor in a single silicon chip [1]. Thus, the number of power devices in a given circuit can be reduced. This integration yields a substantial improvement in the static and dynamic characteristics of the device, as well as improved overall circuit performance.

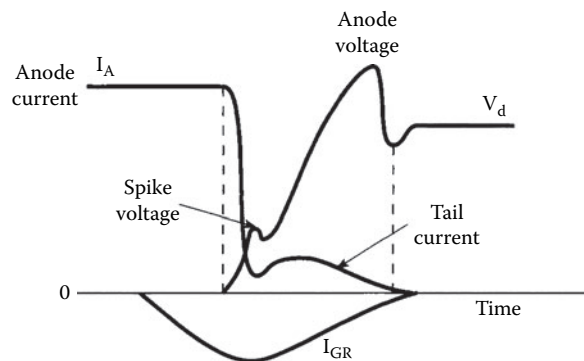


Figure 8.13 Turn-off characteristics of a GTO. (After [1] and [2].)

The RCT is designed mainly for specific applications such as traction drives. The antiparallel diode limits the reverse voltage across the thyristor to 1 to 2 V. Also, because of the reverse recovery behavior of the diodes, the thyristor may see very high reapplied  $dv/dt$  when the diode recovers from its reverse voltage. This necessitates use of large RC snubber networks to suppress the voltage transients. As the range of application of thyristors and diodes extends into higher frequencies, their reverse recovery charge becomes increasingly important. High reverse recovery charge results in high power dissipation during switching.

### 8.2.4 Asymmetrical Silicon-Controlled Rectifier

The *asymmetrical silicon-controlled rectifier* (ASCR) has a forward blocking capability similar to an inverter-grade thyristor, but a limited reverse blocking capability (about 20 to 30 V) [1]. The ASCR has an on-state voltage drop of about 25% less than an inverter-grade thyristor of a similar rating. The ASCR features a fast turn-off time, and so it can work at higher frequencies than typical SCRs. Because the turn-off time is reduced by a factor of nearly 2, the size of the commutating components can be halved. The switching losses, therefore, also are reduced.

Gate-assisted turn-off techniques can be used to further reduce the turn-off time of an ASCR. The application of a negative voltage to the gate during turn-off helps to evacuate stored charges in the device and aids the recovery mechanism. This will — in effect — reduce the turn-off time by a factor of up to 2 over the conventional device.

### 8.2.5 Fusing

Current-limiting is a basic method of protection for thyristors operated from the utility ac line. The device typically used for breaking fault currents is either a fuse or a circuit breaker. Some designs incorporate both components. *Semiconductor fuses* often are used in conjunction with a circuit breaker to provide added protection. Semiconductor fuses operate more rapidly (typically within 8 ms) and more predictably than common fuses or circuit breakers. Surge currents caused by a fault can destroy a semiconductor device, such as a power thyristor, before the ac line circuit breaker has time to act. Manufacturers of semiconductor fuses and thyristors usually specify in their data sheets the  $I^2t$  ratings of each device. Because the thyristor rating normally assumes that the device is operating at maximum rated current and maximum junction temperature (conditions that do not represent normal operation), a safety factor is ensured.

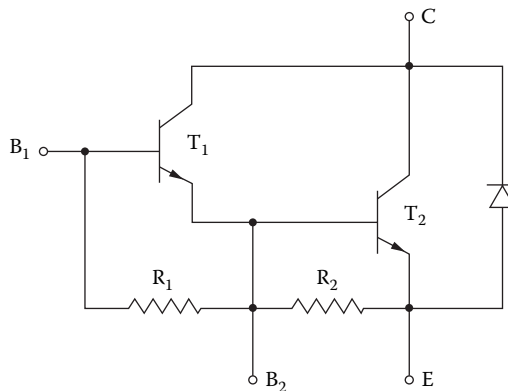
## 8.3 Power Transistors

Power transistors are used in ac applications ranging up to several hundred kilowatts and switching frequencies up to approximately 10 kHz [1]. Devices for power conversion applications are generally npn type. The power transistor is turned on by supplying sufficient base current, which must be maintained throughout the conduction period. The device is turned off by removing the base drive and making the base voltage slightly negative. The *saturation voltage* of the device is normally 0.5 to 2.5 V and increases as the current increases. The transistor off-state losses are much lower than the on-state losses because the leakage current of the device is of the order of a few milliamperes. Because of relatively long switching times, switching losses significantly increase with switching frequency.

Power transistors do not have  $I^2t$  withstand capability. In other words, they can absorb very little energy before breakdown. Therefore, they cannot be protected by semiconductor fuses (like thyristors can), and thus an electronic protection method usually must be provided.

To reduce high base current requirements, Darlington configurations are commonly used. They are available in monolithic or in isolated package designs. The basic Darlington configuration is shown schematically in Figure 8.14. The Darlington arrangement offers a specific advantage in that it can considerably increase the current switched by the transistor for a given base drive.





**Figure 8.14** A two-stage Darlington transistor with bypass diode. (After [1] and [2].)

### 8.3.1 Power MOSFET

Power MOSFETs are a class of devices marketed under a variety of names by different manufacturers [1]. They have unique features that make them particularly attractive for switching applications. Power MOSFETs are essentially voltage-driven rather than current-driven devices (unlike bipolar transistors).

The gate of a MOSFET is isolated electrically from the source by a layer of silicon oxide. The gate draws only a minute leakage current on the order of nanoamperes. Hence, the gate drive circuit is simple, and power loss in the gate control circuit is practically negligible. Although in steady-state, the gate draws virtually no current, this is not so under transient conditions. The gate-to-source and gate-to-drain capacitances have to be charged and discharged appropriately to obtain the desired switching speed, and the drive circuit must have a sufficiently low output impedance to supply the required charging and discharging currents.

Power MOSFETs are majority carrier devices, and there is no minority carrier storage time. This attribute provides for exceptionally fast rise and fall times. Power MOSFETs are essentially resistive devices when turned on, whereas bipolar transistors present a more or less constant saturation voltage  $V_{CE(sat)}$  over the normal operating range. At low currents, therefore, a power MOSFET may have a lower conduction loss than a comparable bipolar device, but at higher currents, the conduction loss will exceed that of the bipolar device.

#### 8.3.1.1 Rugged MOSFET

With recent advancements in MOS technology, ruggedized MOSFETs are replacing conventional MOSFETs in numerous applications [1]. Theoretically, the secondary breakdown mechanism is absent in a power MOSFET. In the real world of *vertical conductive power* MOSFETs, however, secondary breakdown exists because of the presence of a parasitic npn transistor, thus forcing chip designers to develop the ruggedness concept to thwart such failures. The need to ruggedize power MOSFETs is related to device reliability. If a MOSFET is operated within its specification range at all times, its chances for failing catastrophically are minimal. However, if the absolute maximum ratings are exceeded, failure probability increases dramatically. Under actual operating conditions, a MOSFET may be subjected to transients either externally from the power bus supplying the circuit or from the circuit itself, caused, for example, by inductive kicks going beyond the absolute maximum ratings. Such conditions are likely in almost every application and, in many cases, are beyond the control of the designer.

The difference between a ruggedized MOSFET and a conventional device is that the ruggedized version is rated to withstand a specific amount of unclamped avalanche energy when operated at voltages above its maximum drain-to-source breakdown voltage ( $BV_{DSS}$ ). In effect, the manufacturer guarantees that MOSFET will not fail catastrophically up to a specified amount of avalanche energy.

### 8.3.2 Insulated-Gate Bipolar Transistor

The IGBT combines the high input impedance and high-speed characteristics of a MOSFET with the conductivity characteristic (low saturation voltage) of a bipolar transistor [1]. The equivalent circuit of an IGBT is shown in Figure 8.15. The IGBT is turned on by applying a positive voltage between the gate and emitter, and as with the MOSFET, it is turned off by making the gate signal zero or slightly negative. The IGBT has a much lower on-state resistance than a MOSFET.

In a sense, the device is similar to a thyristor and MOSFET. To illustrate: for a given IGBT, there is a critical value of drain current that will cause a large enough voltage drop to activate the thyristor element. Hence, device manufacturers specify the peak allowable drain current that can flow without latch-up occurring. There is also a corresponding gate source voltage that permits this current to flow, which should not be exceeded. After the IGBT is in latch-up, the gate no longer has any control of the drain current. The only way to turn off the IGBT in this situation is by forced commutation of the current, exactly the same as for a thyristor. If latch-up is not terminated quickly, the IGBT will be destroyed by the excessive power dissipation. Under dynamic conditions, when the IGBT is switching from on to off, it may latch up at drain current values less than the values described here (*static latch-up current* value). Various improvements to the basic IGBT design have increased the latching current to workable values.

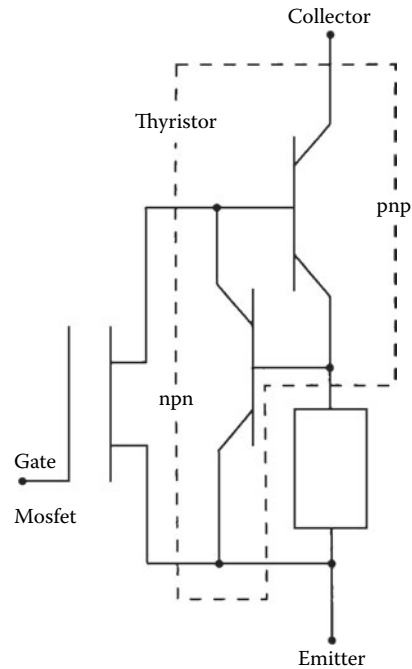
Like the power MOSFET, the IGBT does not exhibit the secondary breakdown phenomenon common to bipolar transistors. However, care should be taken not to exceed the maximum power dissipation and specified maximum junction temperature of the device under all conditions for guaranteed reliable operation.

The on-state voltage of the IGBT is heavily dependent on the gate voltage. To obtain a low on-state voltage, a sufficiently high gate voltage must be applied. The on-state voltage also increases with temperature. Compared to a MOSFET structure, the IGBT is generally smaller for the same current rating. At voltages above 400 V, an IGBT can be one third the size of a MOSFET. The bipolar action in the IGBT, however, slows down the speed of the device so that it typically operates at a much lower frequency than the MOSFET. The switching frequency can be as high as 50 kHz for a standard device; higher frequencies are achievable at the expense of higher losses.

The IGBTs cannot be as easily paralleled as MOSFETs can. The factors that inhibit current sharing of parallel-connected IGBTs are:

- The on-state current unbalance, caused by  $V_{CE(sat)}$  distribution and main circuit wiring resistance distribution
- Current unbalance at turn-on and turn-off, caused by the switching time difference of the parallel-connected devices and circuit wiring inductance distribution

If IGBT devices having different turn-on times are paralleled, the current is hogged by the device having the shorter turn-on time. If IGBTs having different turn-off times are paralleled, current is hogged by the device having the longer turn-off time. The time differences at turn-off must be controlled carefully because turn-off times are greater than those of turn-on.

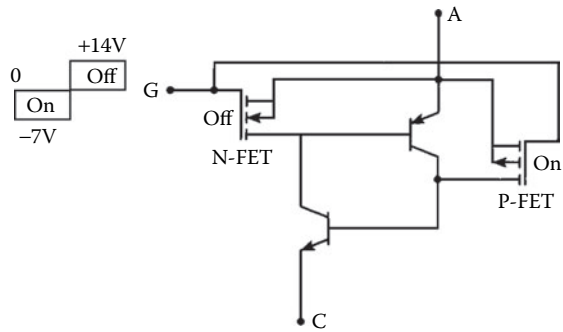


**Figure 8.15** The equivalent circuit of the IGBT device. (After [1] and [2].)

### 8.3.3 MOS-Controlled Thyristor

The *MOS-controlled thyristor* (MCT) is basically a thyristor with built-in MOSFETs to turn on and turn off the circuit [1]. Device attributes include high-power, high-frequency, low-conduction-drop, and ruggedness. The MCT equivalent circuit is shown in Figure 8.16. The MCT has thyristor-type junctions and pnpn layers between the anode and cathode.

The MCT is turned on by a negative voltage pulse at the gate, with respect to the anode, and turned off by a positive voltage pulse. The MCT can operate at higher junction temperatures than the BJT, IGBT, and MOSFET. The MCT has relatively low switching times and storage time. The MCT is capable of high current densities and blocking voltages in both directions. Because the power gain of an MCT is extremely high, it can be driven directly from a logic gate.



**Figure 8.16** The equivalent circuit of the MCT device. (After [1] and [2].)

## 8.4 References

1. Rajashekara, K., A. K. S. Bhat, and B. K. Bose, "Power Electronics," in *The Electrical Engineering Handbook*, Richard Dorf (Ed.), CRC Press, Boca Raton, FL, pp. 694–701, 1993.
2. Bose, B. K., *Modern Power Electronics: Evaluation, Technology, and Applications*, IEEE, New York, 1992.

## 8.5 Bibliography

- Fink, D., and D. Christiansen (Eds.), *Electronics Engineers' Handbook*, 3<sup>rd</sup> ed., McGraw-Hill, New York, 1989.
- Jordan, Edward C. (Ed.), *Reference Data for Engineers: Radio, Electronics, Computer, and Communications*, 7th ed., Howard W. Sams Company, Indianapolis, IN, 1985.
- Pearman, R., *Power Electronics*, Reston Publishing Company, Reston, VA, 1980.
- Mohan, N., and T. Undeland, *Power Electronics: Converters, Applications, and Design*, John Wiley, New York, 1989.
- SCR Applications Handbook*, International Rectifier Corporation, El Segundo, CA, 1977.
- SCR Manual*, 5th ed., General Electric Company, Auburn, NY.
- Wojslawowicz, J., "Ruggedized Transistors Emerging as Power MOSFET Standard-Bearers," *Power Technics*, pp. 29–32, January 1988.

# Origins of AC Line Disturbances

---

## 9.1 Introduction

---

Transient overvoltages come in a wide variety of forms, from a wide variety of sources. They can, however, be broken down into two basic categories: (1) those generated through natural occurrences, and (2) those generated through the use of equipment, either on-site or elsewhere.

## 9.2 Naturally Occurring Disturbances

---

Natural phenomena of interest to facility managers consist mainly of lightning and related disturbances. The *lightning effect* can be compared to that of a capacitor, as shown in [Figure 9.1](#). A charged cloud above the Earth will create an oppositely charged area below it of about the same size and shape. When the voltage difference is sufficient to break down the dielectric (air), the two “plates” of the “capacitor” will arc over and neutralize their respective charges. If the dielectric spacing is reduced, as in the case of a conductive steel structure (such as a transmitting tower), the arc-over will occur at a lower-than-normal potential and will travel through the conductive structure.

The typical duration of a lightning flash is approximately 0.5 s. A single flash is made up of various discharge components, among which are typically three or four high-current pulses called *strokes*. Each stroke lasts about one 1 ms; the separation between strokes is typically several tens of milliseconds. Lightning often appears to flicker because the human eye can just resolve the individual light pulses that are produced by each stroke.

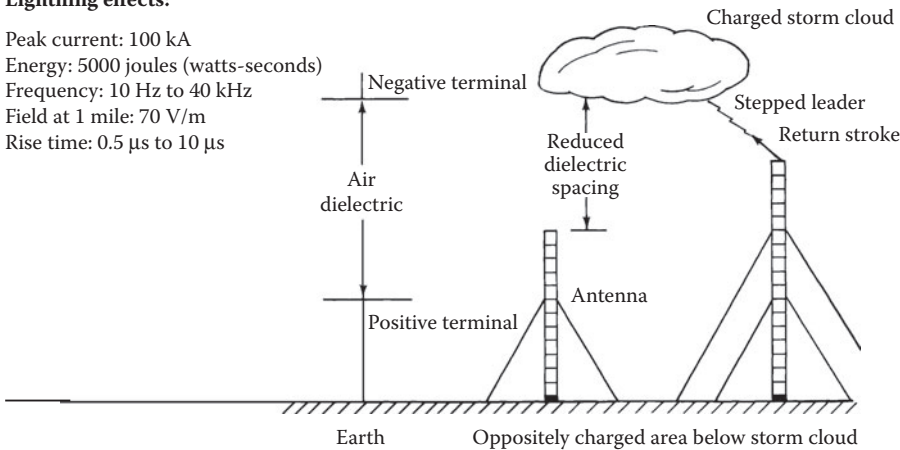
### 9.2.1 Sources of Atmospheric Energy

Lightning is one of the more visible effects of atmospheric electricity. Stellar events that occurred light-years ago spray the earth and its atmosphere with atoms that have been stripped of most or all of their electrons. In the process of entering the atmosphere, these particles collide with air molecules, which are knocked apart, creating billions more ion pairs each second. Even though these ions may exist for only about 100 s, they constantly are being replenished from deep space. The existence of ions in the atmosphere is the fundamental reason for atmospheric electricity. The primary sources of this energy are:

- *Cosmic rays*: Charged particles emitted by all radiating bodies in space. Most of these particles (ions) expend their energy in penetrating the envelope of air surrounding the earth. Through this process, they create more ions by colliding with air atoms and molecules. One high-energy particle may create up to a billion pairs of ions, many of which will become atmospheric electricity.
- *Solar wind*: Charged particles from the sun that continuously bombard the surface of the earth. Because about half of the earth's surface is always exposed to the sun, variations are experienced from day to night. Solar wind particles travel at only 200 to 500 miles per second, compared with cosmic particles that travel at near the speed of light. Because of their slower speed, solar wind particles have less of an effect on air atoms and molecules.

**Lightning effects:**

Peak current: 100 kA  
 Energy: 5000 joules (watts-seconds)  
 Frequency: 10 Hz to 40 kHz  
 Field at 1 mile: 70 V/m  
 Rise time: 0.5  $\mu$ s to 10  $\mu$ s

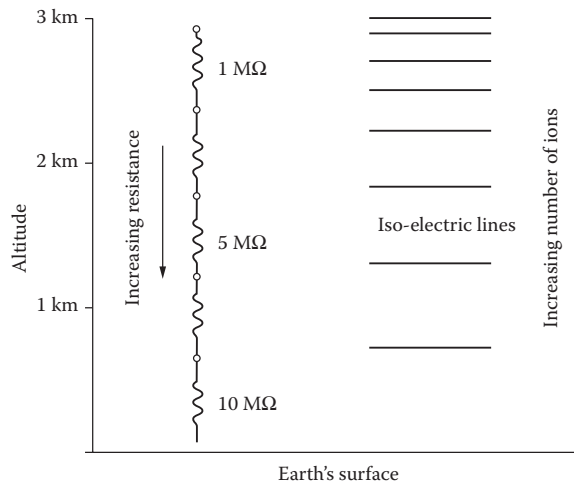


**Figure 9.1** The lightning effect and how it can be compared to a more familiar mechanism, the capacitor principle. Also shown are the parameters of a typical lightning strike.

- *Natural radioactive decay:* The natural disintegration of radioactive elements. In the process of radioactive decay, air molecules are ionized near the surface of the earth. One of the results is radon gas.
- *Static electricity:* Energy generated by the interaction of moving air and the earth.
- *Electromagnetic generation:* Energy generated by the movement of air molecules through the magnetic field of the earth.

The combined effects of cosmic rays and solar wind account for most atmospheric electrical energy.

Atmospheric energy is present at all times, even during clear weather conditions. This energy takes the form of a voltage differential of 300 to 400 kV between the surface of the earth and the ionosphere. The voltage gradient is nonlinear; near the surface it may be 150 V/m of elevation, but it diminishes significantly at higher altitudes. Under normal conditions, the earth is negative with respect to the ionosphere, and ions flow between the two entities. Because there are fewer free ions near the Earth than the ionosphere, the volts/meter value is thought to be greater because of the lower effective conductivity of the air. This concept is illustrated in Figure 9.2.



**Figure 9.2** The effects of atmospheric conductivity.

Thermodynamic activity in a developing storm cloud causes it to become a powerfully charged cell, usually negatively charged on the bottom and positively charged on the top. (See Figure 9.3.) This voltage difference causes a distortion in the voltage gradient, and in fact, the polarity inverts, with the earth becoming positive with reference to the bottom of the cloud. This voltage gradient increases to a high value, sometimes exceeding 10 kV/m of elevation. The overall charge between the earth and the cloud may be on the order of 10 to 100 MV, or more. When sufficient potential difference exists, a lightning flash may occur.

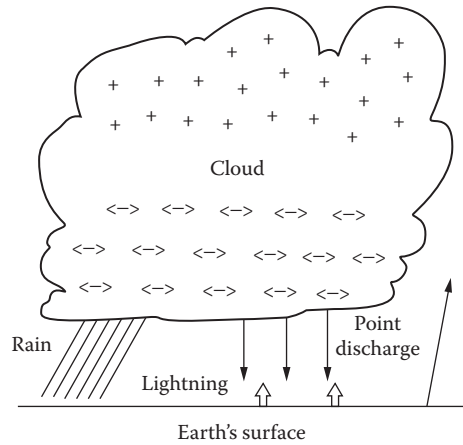


Figure 9.3 A developing thunderstorm cell.

Figure 9.4 shows the flash waveform for a typical lightning discharge. The rise time is very fast, in the microsecond range, as the lightning channel is established. The trailing edge exhibits a slow decay; the decay curve is known as a *reciprocal double exponential waveform*. The trailing edge is the result of the resistance of the ionized channel depleting energy from the cloud. The path length for a lightning discharge is measured in kilometers. The most common source of lightning is cumulonimbus cloud forms, although other types of clouds (such as nimbostratus) occasionally can produce activity.

Although most lightning strikes are negative (the bottom of the cloud is negative with respect to the earth), positive strikes also can occur. Such strikes have been estimated to carry as much as 10 times the current of a negative strike. A positive flash can carry 200 kiloamps (kA) or more of discharge current. Such hot strikes, as they are called, can cause considerable damage. Hot strikes can occur in the winter and are often the aftereffect of a particularly active storm. After a number of discharges, the lower negative portion of the cloud will become depleted. When charged, the lower portion may have functioned as a screen or shield between the earth and the upper, positively charged portion of the cloud. When depleted, the shield is removed, exposing the earth to the massive charge in the upper cloud containing potentials of perhaps 500 MV or more.

### 9.2.2 Characteristics of Lightning

A typical lightning flash consists of a stepped leader that progresses toward the ground at a velocity that can exceed 50 m/μs. When sufficient potential difference between the cloud and the ground exists, arcs

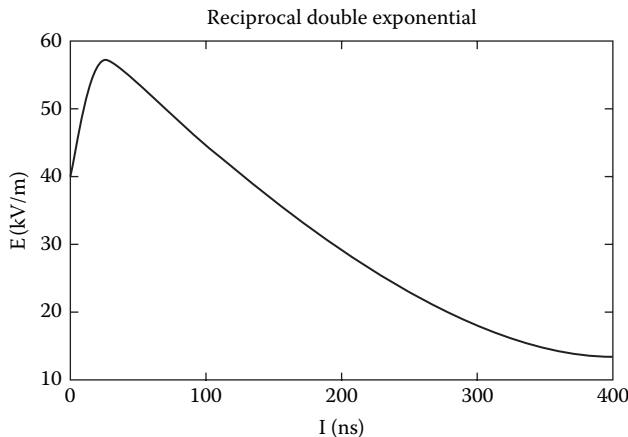


Figure 9.4 Discharge waveform for a typical lightning strike.

move from the ground to the leader column, completing the ionized column from cloud to ground. A fast and bright return stroke then moves upward along the leader column at about one third the speed of light. Peak currents from such a lightning flash may exceed 100 kA, with a total charge as high as 100 coulombs (C). Although averages are difficult to assess where lightning is concerned, a characteristic flash exhibits a 2  $\mu$ s rise time, and a 10 to 40  $\mu$ s decay to a 50% level. The peak current will average 18 kA for the first impulse, and about half that for the second and third impulses. Three to four strokes per flash are common.

A lightning flash is a constant-current source. Once ionization occurs, the air becomes a conductive plasma reaching 60,000°F and becomes luminous. The resistance of an object struck by lightning is of small consequence except for the power dissipation on that object, which is equivalent to  $I^2R$ . Fifty percent of all strikes will have a first discharge of at least 18 kA, 10% will exceed 60 kA, and only 1% will exceed 120 kA.

Four specific types of cloud-to-ground lightning have been identified. They are categorized in terms of the direction of motion (upward or downward) and the sign of the electric charge (positive or negative) of the initiating leader. The categories, illustrated in Figure 9.5, are defined as follows:

- *Category 1:* Negative leader cloud-to-ground discharge. By far the most common form of lightning, such discharges account for 90% or more of the cloud-to-ground flashes worldwide. Such events are initiated by a downward-moving negatively charged leader.
- *Category 2:* Positive leader ground-to-cloud discharge. This event begins with an upward-initiated flash from earth, generally from a mountaintop or tall steel structure. Category 2 discharges are relatively rare.
- *Category 3:* Positive leader cloud-to-ground discharge. Less than 10% of cloud-to-ground lightning worldwide is of this type. Positive discharges are initiated by leaders that do not exhibit the distinct steps of their negative counterparts. The largest recorded peak currents are in the 200 to 300 kA range.
- *Category 4:* Negative leader ground-to-cloud discharge. Relatively rare, this form of lightning begins with an upward leader that exhibits a negative charge. Similar to Category 2 discharges, Category 4 discharges occur primarily from a mountaintop or tall steel structure.

An idealized lightning flash is shown in Figure 9.6. The stepped leader initiates the first return stroke in a negative cloud-to-ground flash by propagating downward in a series of discrete steps, as shown. The breakdown process sets the stage for a negative charge to be lowered to the ground. A fully developed leader lowers 10 C or more of negative cloud charge to near the ground within a few tens of milliseconds. The average return leader current measures from 100 A to 1 kA. During its trip toward earth, the stepped leader branches in a downward direction, producing the characteristic lightning discharge.

The electrical potential difference between the bottom of the negatively charged leader channel and the earth can exhibit a magnitude in excess of 100 MV. As the leader tip nears ground level, the electric field at sharp objects on the ground increases until the breakdown strength of the atmosphere is exceeded. At that point, one or more upward-moving discharges are initiated, and the *attachment process*

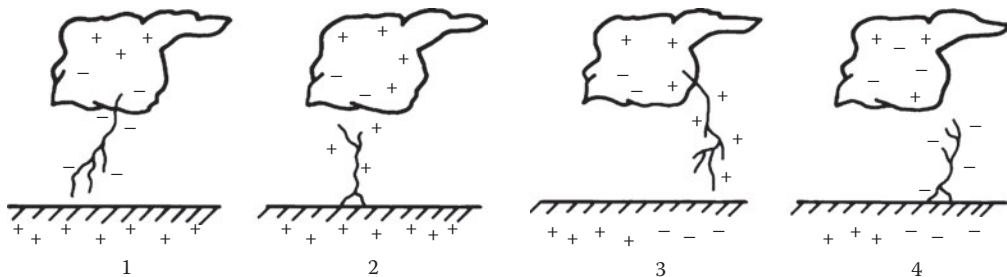


Figure 9.5 Four general types of lightning activity. (After [1].)



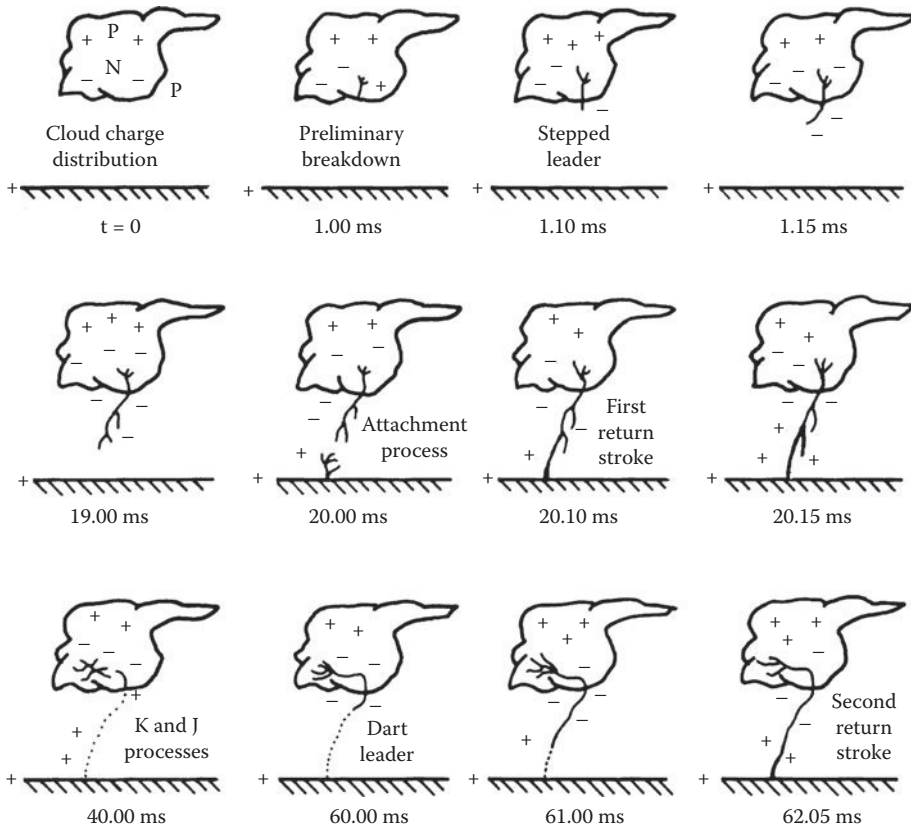


Figure 9.6 The mechanics of a lightning flash. (After [2].)

begins. The leader channel is discharged when the first return stroke propagates up the previously ionized and charged leader path. This process will repeat if sufficient potential exists after the initial stroke. The time between successive strokes in a flash is usually several tens of milliseconds.

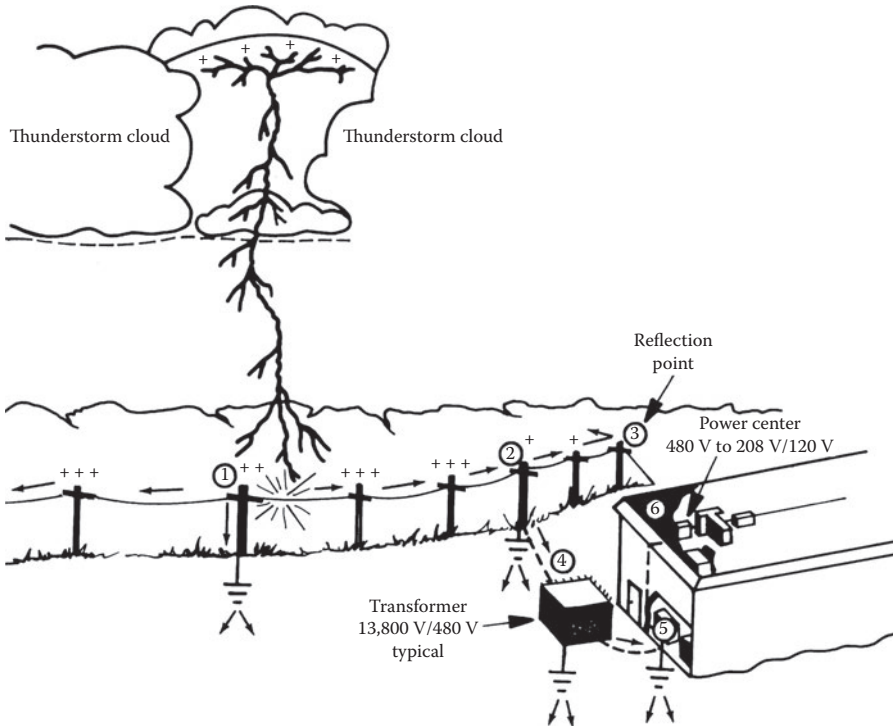
### 9.2.2.1 Cloud-to-Cloud Activity

A cloud discharge can be defined as any lightning event that does not connect with the earth. Most lightning discharges occur within the confines of the cloud. Cloud discharges can be subdivided into *intracloud*, *intercloud*, and *cloud-to-air* flashes. Although relatively insignificant insofar as earthbound equipment is concerned, current movement between clouds can create a corresponding *earth current*.

It is estimated that only about 10 to 25% of lightning occurs from cloud to ground; most discharges consist of intracloud activity. The reason is the enormous voltage difference that builds up between the top and bottom of a storm cloud. Furthermore, the region between the top and bottom of the cloud can be more highly ionized than the region between the bottom of the cloud and the earth. Currents developed by cloud-to-cloud discharges can induce significant voltages in conductors buried in-line with the charge movement. The *windstorm effect* also can induce voltages in above- or below-ground conductors as a result of rapid changes in the electrical potential of the atmosphere.

It is unnecessary, therefore, for atmospheric charge energy to actually strike a conductor of concern, such as a transmitting tower or utility company pole. In many cases, significant voltage transients can be generated solely by induction. Cloud-to-cloud charge movements generate horizontally polarized radiation, and cloud-to-ground discharges generate vertically polarized radiation. Field strengths exceeding 70 V/m can be induced in conductors a mile or so from a large strike.





**Figure 9.7** The mechanisms of lightning surge on an overhead power-distribution line.

Figure 9.7 illustrates the mechanisms of lightning damage. Traveling waves of voltage and current follow all conductive paths until the flash energy has been dissipated. Reflections occur at discontinuities, such as lightning arresters (points 1, 2, 3, and 5) and transformers (points 4 and 6).

### 9.2.3 Lightning Protection

Research into the physical properties of lightning and related phenomena has two basic goals: (1) to identify the character and severity of the threat, and (2) to devise methods to prevent damage resulting from atmospheric activity. Many different approaches have been taken over the years for controlling the damaging potential of lightning; some have become widely accepted, others remain controversial. The issue of lightning prevention clearly falls into the second category.

Application of the *point discharge* theory, the basis of lightning prevention schemes, is controversial to begin with. Still, it offers the promise of a solution to a serious problem faced by nearly all telecommunications operators. The goal is to dissipate static charges around a given structure at a rate sufficient to maintain the charge below the value at which a lightning flash will occur. The theory holds that discharge from the point of an electrode to a surrounding medium will follow predictable rules of behavior. The sharper the point, the greater the discharge. The greater the number of discharge points, the more efficient the dissipation system. Several static dissipators based on this theory are shown in Figure 9.8. Key design elements for such dissipators include:

- Radius of the dissipator electrode. The purpose of the dissipator is to create a high field intensity surrounding the device. Theory states that the electric field intensity will increase as the electrode radius is reduced. Dissipators, therefore, generally use the smallest-radius electrodes possible, consistent with structural integrity. There is, however, disagreement among certain dissipation-array manufacturers on this point. The optimum wire size, according to available literature, varies from 0.005-in.- to 1/8-in.-thick tapered spikes.

- Dissipator construction material. Important qualities include conductivity and durability. The dissipator should be a good conductor to provide: (1) the maximum discharge of current during normal operation, and (2) an efficient path for current flow in the event of a direct strike.
- Number of dissipator electrodes. Calculating the number of dissipator points is, again, the subject of some debate. However, because the goal of the system is to provide a low-resistance path to the atmosphere, it generally is assumed that the more discharge points, the more effective the system. Dissipator electrode requirements are determined by the type of structure being protected as well as the environmental features surrounding it.
- Density of dissipator electrodes. Experimentation by some manufacturers has shown that the smaller the radius of the dissipator electrodes, the more closely they can be arranged without reducing the overall efficiency of the dissipator. Although this convention seems reasonable, disagreement exists among dissipation-array manufacturers. Some say the points should be close together; others say they should be far apart.
- Configuration of the dissipator on the tower. Disagreement abounds on this point. One school of thought supports the concept of a dedicated “umbrella-type” structure at the top of the tower as the most efficient method of protecting against a lightning flash (Figure 9.9). Another view holds that the dissipator need not be at the highest point, and that it may be more effective if one or more dissipators are placed at natural dissipation points on the structure. Such points include side-mounted antennas and other sharp elements on the tower.
- Size and deployment of grounding electrodes. Some systems utilize an extensive ground system, others do not. One manufacturer specifies a collector composed of wire radials extending from the base of the tower and terminated by ground rods. Another manufacturer does not require a ground connection to the dissipator.

Available literature indicates that from 10  $\mu\text{A}$  to 10 mA flow through a properly designed dissipative system into the surrounding air during a lightning storm. Figure 9.10 charts the discharge current recorded during a period of storm activity at a protected site. Although a lightning stroke can reach several hundreds of thousands of amperes, this energy flows for a very short period of time. The concept of the dissipative array is to continuously bleed off space charge current to prevent a direct hit.

Proof that static dissipators work as intended is elusive and depends upon the definition of “proof.” Empirical proof is difficult to obtain because successful performance of a static dissipator is evidenced by the absence of any results. Supporting evidence, both pro and con, is available from end-users of static dissipators, and from those who have studied this method of reducing the incidence of lightning strikes to a structure.

### 9.2.3.1 Protection Area

The placement of a tall structure over low-profile structures tends to protect the facilities near the ground from lightning flashes. The tall structure, typically a communications tower, is assumed to shield the facility below it from hits. This *cone of protection* is determined by the following:

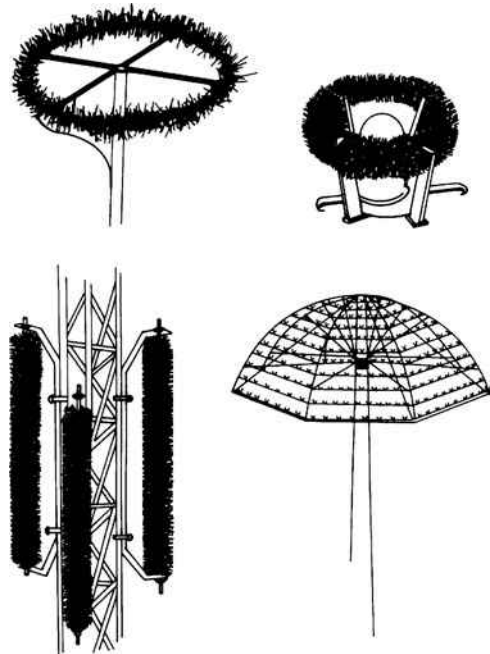


Figure 9.8 Various types of static dissipation arrays.

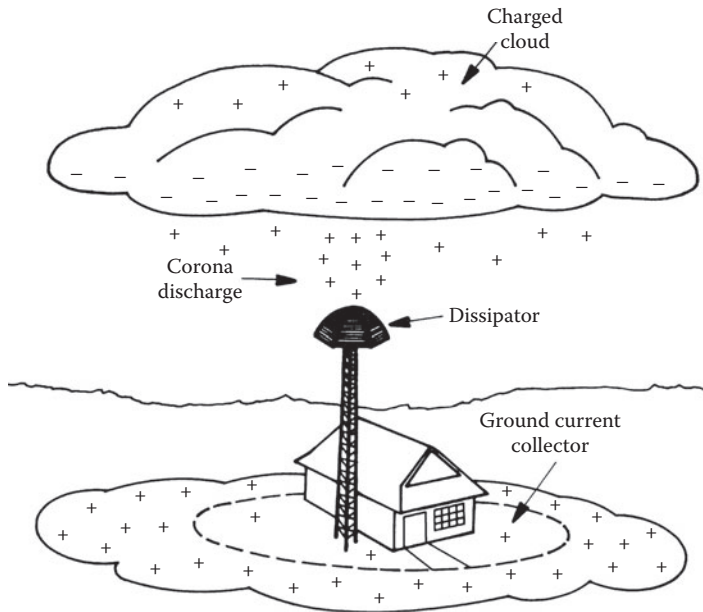


Figure 9.9 Umbrella-type dissipation array.

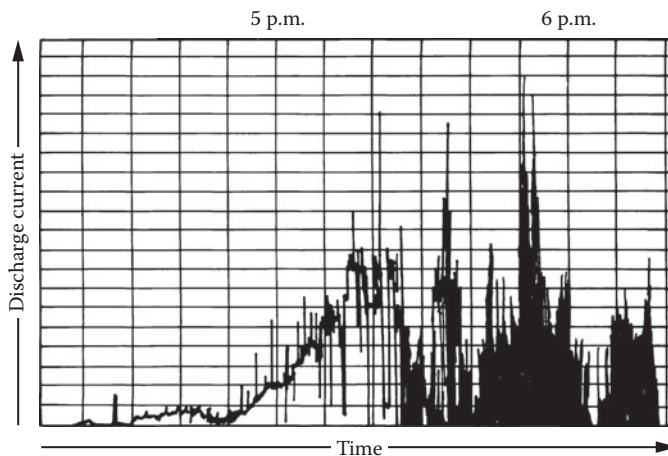


Figure 9.10 Measured discharge current of a lightning dissipation array.

- Height of the tall structure
- Height of the storm cloud above the earth

The higher the cloud, the larger the radius of the base of the protecting cone. The ratio of radius to base to height varies approximately from 1 to 2, as illustrated in Figure 9.11.

Conventional wisdom has held that a tower, whether protected with a static dissipation array or simply a tower-top lightning rod, provided a cone of protection stretching out on all sides of the structure at an angle of about 45°. Although this theory held favor for many years, modifications have been proposed. One school of thought suggests that a smaller cone of perhaps 30° from the tower is more realistic. Another suggests that the cone theory is basically flawed and, instead, proposes a “rolling sphere” approach. This theory states that areas enclosed below a 150-ft rolling sphere will enjoy protection against lightning strikes. The concept is illustrated in Figure 9.12. Note that the top of the tower shown in

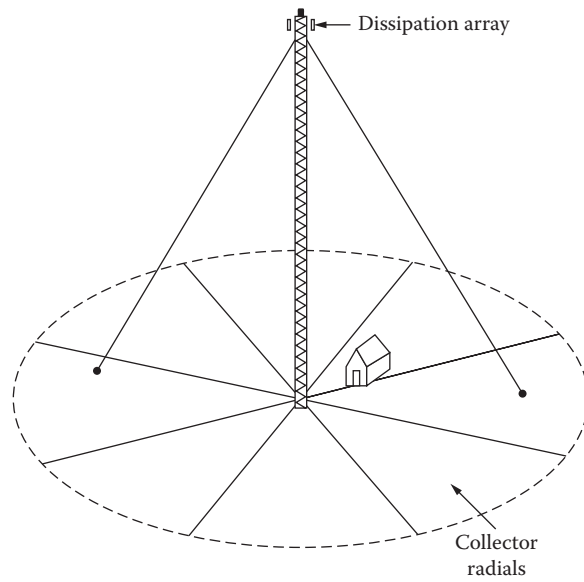


Figure 9.11 Intended protection area for a dissipation array.

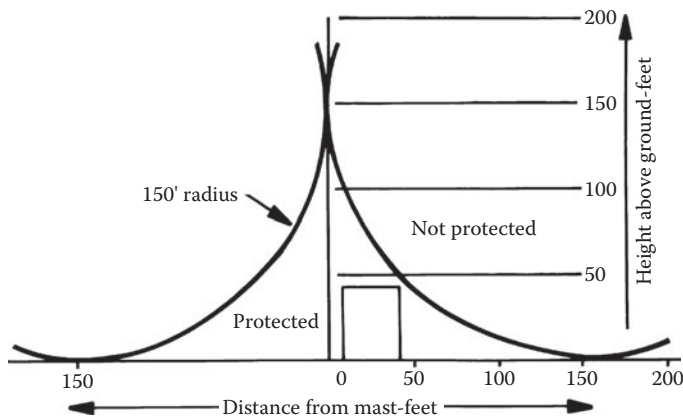


Figure 9.12 Protection zone for a tall tower under the “rolling sphere” theory.

the figure is assumed to experience limited protection. The concept, as it applies to side-mounted antennas, is shown in Figure 9.13. The antenna is protected through the addition of two horizontally mounted lightning rods, one above the antenna and one below.

### 9.2.4 Electrostatic Discharge

A static charge is the result of an excess or deficiency of electrons on a given surface. The relative level of electron imbalance determines the static charge. Simply stated, a charge is generated by physical contact between, and then separation of, two materials. One surface loses electrons to the other. The types of materials involved, and the speed and duration of motion between the materials, determine the charge level. Electrostatic energy is a stationary charge phenomenon that can build up in either a nonconductive material or in an ungrounded conductive material. The charge can occur in one of two ways:

- *Polarization*: Charge buildup when a conductive material is exposed to a magnetic field.

- *Triboelectric effects*: Charge buildup that occurs when two surfaces contact and then separate, leaving one positively charged and the other negatively charged.

Friction between two materials increases the triboelectric charge by increasing the surface area that experiences contact. For example, a person accumulates charge by walking across a nylon carpet; discharge occurs when the person touches a conductive surface.

#### 9.2.4.1 Triboelectric Effect

Different materials have differing potentials for charge. Nylon, human and animal hair, wool, and asbestos have high positive triboelectric potential. Silicon, polyurethane, rayon, and polyester have negative triboelectric potentials. Cotton, steel, paper, and wood all tend to be relatively neutral materials. The intensity of the triboelectric charge is inversely proportional to the relative humidity (RH). As humidity increases, *electrostatic discharge* (ESD) problems decrease. For example, a person walking across a carpet can generate a 1.5 kV charge at 90% RH, but will generate as much as 35 kV at 10% RH.

When a charged object comes in contact with another object, the electrostatic charge will attempt to find a path to ground, discharging into the contacted object. The current level is very low (typically less than 0.1 nA), but the voltage can be high (25 to 50 kV).

ESD also can collect on metallic furnishings, such as chairs and equipment racks. Sharp corners and edges, however, encourage a corona that tends to bleed the charge off such objects. The maximum voltage normally expected for furniture-related ESD is about 6 to 8 kV. Because metallic furniture is much more conductive than humans, however, furniture-related ESD generally will result in higher peak discharge currents. Figure 9.14 shows a discharge waveform of a typical ESD event.

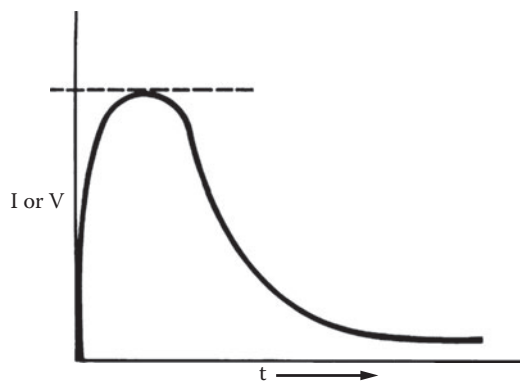


Figure 9.14 Discharge waveform for an ESD event. (After [3].)

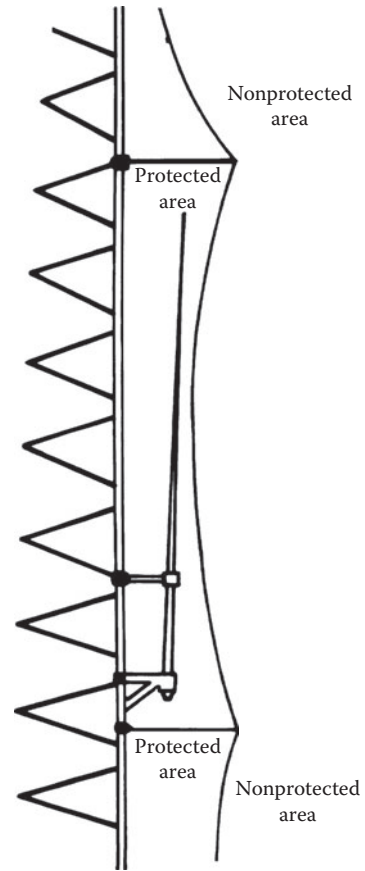
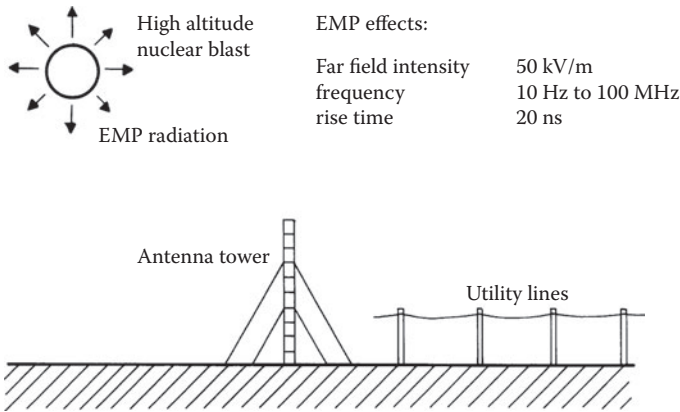


Figure 9.13 Protection zone for a side-mounted antenna under the “rolling sphere” theory.



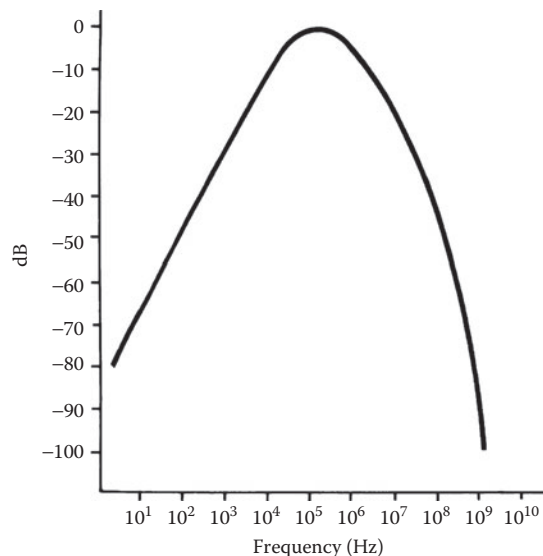
**Figure 9.15** The EMP effect and how it can induce damaging voltages onto utility company lines and antenna structures. The expected parameters of an EMP event also are shown.

### 9.2.5 EMP Radiation

*Electromagnetic pulse* (EMP) radiation is the result of an intense release of electromagnetic waves that follows a nuclear explosion. (See Figure 9.15.) The amount of damaging energy is a function of the altitude of detonation and the size of the device. A low-altitude or surface burst would generate a strong EMP, covering a few thousand square kilometers. However, the effects of the radiation would be meaningless, because the blast would destroy most structures in the area. A high-altitude burst, on the other hand, presents a real threat to all types of communications and electronic systems. Such an explosion would generate an EMP with a radius of more than 1000 km, a large portion of the U.S.

The sudden release of gamma rays in a nuclear explosion would cause almost instant ionization (the removal of electrons from atoms) of the atmospheric gases that surround the detonation area. Free electrons are driven outward. In a high-altitude event, the gamma rays travel great distances before ionizing the upper atmosphere. The forced movement of these electrons, which will again recombine with atoms in the atmosphere, creates a pulsed electromagnetic field.

The amplitude and polarization of the field produced by a high-altitude detonation depends on the altitude of the burst, the yield of the device, and the orientation of the burst with respect to the receiving point. The EMP field creates a short but intense broadband radio frequency pulse with significant energy up to 100 MHz. Most of the radiated energy, however, is concentrated below 10 MHz. Figure 9.16 shows the distribution of energy as a function of frequency. The electric field can be greater than 50 kV/m, with a rise time measured in the tens of nanoseconds. Figure 9.17 illustrates the field of a simulated EMP discharge.



**Figure 9.16** Normalized EMP spectrum. Approximately 99% of the radiated energy is concentrated between 10 kHz and 100 MHz.

Many times, lightning and other natural occurrences cause problems not because they strike a given site, but because they strike part of the utility power system and are brought into the facility via the ac lines. Likewise, damage that could result from EMP



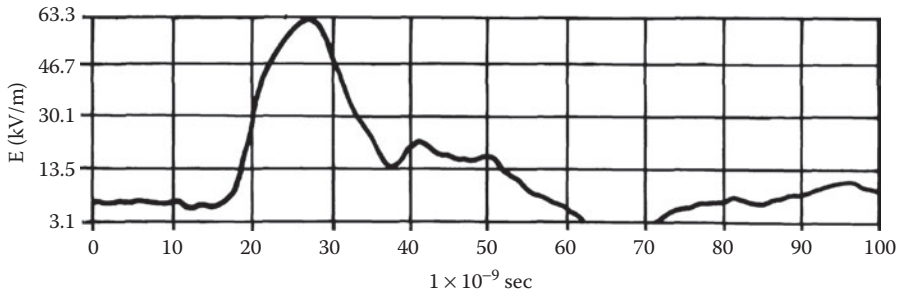


Figure 9.17 Discharge waveform for a nuclear EMP event.

Table 9.1 Effects of an EMP Event on Various Systems

Type of Conductor	Rise Time (s)	Peak Voltage (V)	Peak Current (A)
Long unshielded cable (power line, long antenna)	$10^{-8}$ to $10^{-7}$	$10^5$ to $5 \times 10^6$	$10^3$ to $10^4$
HF antenna system	$10^{-8}$ to $10^{-7}$	$10^4$ to $10^6$	500 to $10^4$
VHF antenna system	$10^{-9}$ to $10^{-8}$	$10^3$ to $10^5$	100 to $10^3$
UHF antenna system	$10^{-9}$ to $10^{-8}$	100 to $10^4$	10 to 100

radiation would be most severe to equipment connected to the primary power source, because it is generally the most exposed part of any facility. Table 9.1 lists the response of various systems to an EMP event.

## 9.2.6 Coupling Transient Energy

The utility power-distribution system can couple transient overvoltages into a customer's load through induction or direct-charge injection. As stated previously, a lightning flash a mile away from a 12 kV line can create an electromagnetic field with a strength of 70 V/m or more. Given a sufficiently long line, substantial voltages can be coupled to the primary power system without a direct hit. Likewise, the field created by EMP radiation can be coupled to the primary power lines, but in this case at a much higher voltage (50 kV/m). Considering the layout of many parts of the utility company power system — long exposed lines over mountaintops and the like — the possibility of a direct lightning flash to one or more legs of the system is a distinct one.

Lightning is a point charge-injection process, with pulses moving away from the point of injection. The amount of total energy (voltage and current) and the rise and decay times of the energy seen at the load as a result of a lightning flash are functions of the distance between the flash and the load and the physical characteristics of the power-distribution system. Determining factors include:

- Wire size
- Number and sharpness of bends
- Types of transformers
- Types of insulators
- Placement of lightning suppressors

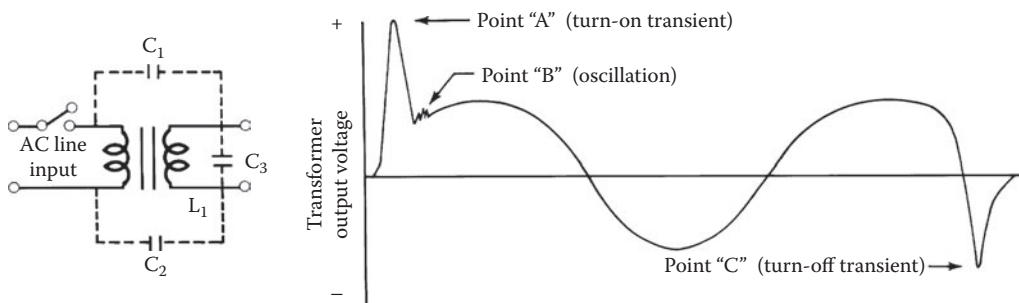
The character of a lightning flash covers a wide range of voltage, current, and rise-time parameters. Making an accurate estimate of the damage potential of a flash is difficult. A direct hit to a utility power line causes a high-voltage, high-current wave to travel away from the point of the hit in both directions along the power line. The waveshape is sawtooth in form, with a rise time measured in microseconds or nanoseconds. The pulse travels at nearly the speed of light until it encounters a significant change in line impedance. At this point, a portion of the wave is reflected back down the line in the direction from which it came. This action creates a standing wave containing the combined voltages of the two pulses. A high-energy wave of this type can reach a potential sufficient to arc over to another parallel line, a distance of about 8 ft on a local feeder (typically 12 kV) power pole.

### 9.3 Equipment-Caused Transient Disturbances

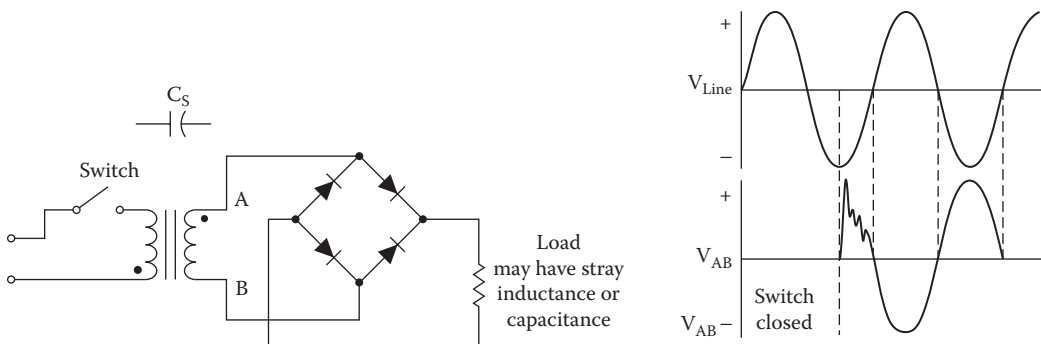
Equipment-caused transients in the utility power system are a consequence of the basic nature of alternating current. A sudden change in an electric circuit will cause a transient voltage to be generated because of the stored energy contained in the circuit inductances ( $L$ ) and capacitances ( $C$ ). The size and duration of the transient depend on the values of  $L$  and  $C$  and the waveform applied.

A large step-down transformer, the building block of any power system, normally will generate transient waveforms when energized or de-energized. As illustrated in Figure 9.18, the stray capacitances and inductances of the secondary can generate a brief oscillating transient of up to twice the peak secondary voltage when the transformer is energized. The length of this oscillation is determined by the values of  $L$  and  $C$  in the circuit.

A more serious problem can be encountered when energizing a step-down transformer. The load is, in effect, looking into a capacitive divider from the secondary into the primary. If the interwinding capacitance is high and the load capacitance is low, a spike of as much as the full primary voltage can be induced onto the secondary, and thus, onto the load. This spike does not carry much energy because of its short duration, but sensitive equipment on the load side could be damaged upon reapplication of power to a utility company pole transformer, for example, as would occur after a power outage. A typical transformer may have 0.002 pF series capacitance from input to output. (See Figure 9.19.) A simple Faraday shielded isolation transformer can reduce this series capacitance to 30 pF, nearly two orders of magnitude lower.

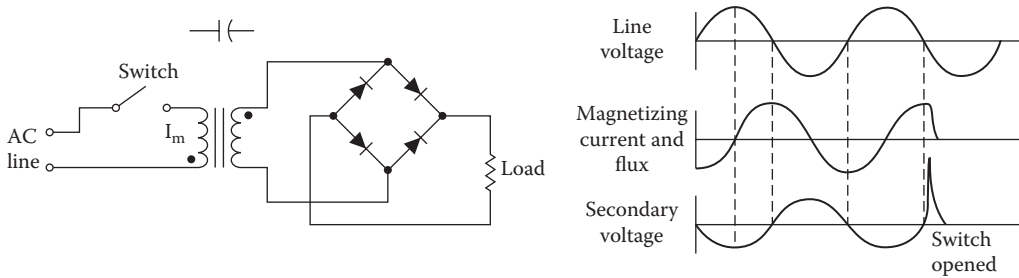


**Figure 9.18** The causes of inductor turn-on and turn-off spikes. The waveforms are exaggerated to illustrate the transient effects.  $C_1$ ,  $C_2$ , and  $C_3$  are stray capacitances that form a divider network between the primary and secondary, causing the turn-on spike shown at point A. The oscillation shown at point B is caused by the interaction of the inductance of the secondary ( $L_1$ ) and  $C_3$ . The spike shown at point C is the result of power interruption to the transformer primary, which causes the collapsing lines of flux to couple a high-voltage transient into the secondary circuit.



**Figure 9.19** Transient produced as a result of transformer capacitance during power-on condition. (After [4].)





**Figure 9.20** Transient generated when interrupting the transformer magnetizing current. (After [4].)

De-energizing a large power transformer also can cause high-voltage spikes to be generated. Interrupting the current to the primary windings of a transformer, unless switched off at or near the zero crossing, will cause the collapsing magnetic lines of flux in the core to couple a high-voltage transient into the secondary circuit, as illustrated in Figure 9.20. If a low-impedance discharge path is not present, this spike will be impressed upon the load. Transients in excess of 10 times the nominal secondary voltage have been observed when this type of switching occurs. Such spikes can have damaging results to equipment on-line. For example, the transient produced by interrupting the magnetizing current to a 150 kVA transformer can measure 9 joules (J). Whether these turn-on, turn-off transients cause any damage depends on the size of the transformer and the sensitivity of the equipment connected to the transformer secondary.

### 9.3.1 Utility System Faults

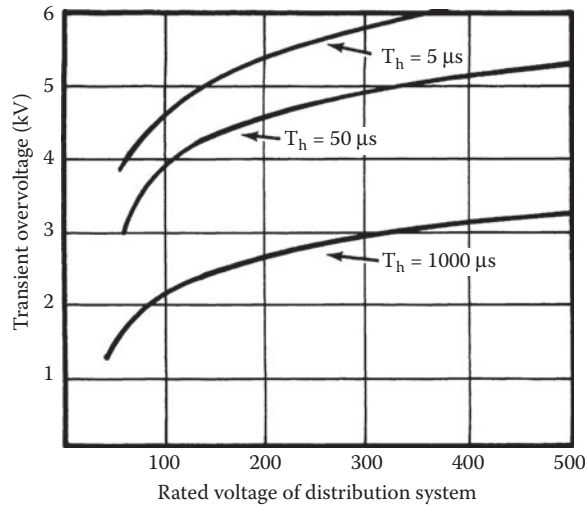
Various utility fault conditions can result in the generation of potentially damaging overvoltage transients. For example, the occurrence of a fault somewhere in the local power-distribution network will cause a substantial increase in current in the step-down transformer at the local area distribution substation. When a fuse located near the fault opens the circuit, the excess stored energy in the magnetic lines of flux of the transformer will cause a large oscillating transient to be injected into the system.

Routine load switching by the utility will have a similar, albeit less serious, effect. Such transient voltages can be quite frequent and, in some instances, harmful to equipment rectifier stacks, capacitors, and transformer. The magnitude of utility company switching transients usually is independent of power-system voltage ratings, as illustrated in Figure 9.21.

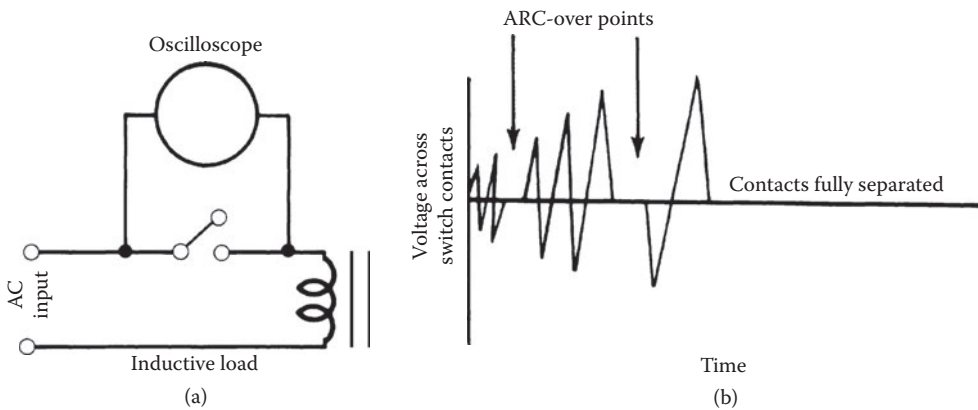
### 9.3.2 Switch Contact Arcing

Transients generated by contact bounce occur not only because of physical bouncing upon closing or opening, but also because of arcing between contacts, the result of transients that are generated when an inductive load is de-energized. The principle is illustrated in Figure 9.22. When current is interrupted to an inductor, the magnetic lines of flux will try to maintain themselves by charging stray capacitances. The current will oscillate in the inductance and capacitance at a high frequency. If sufficiently high voltages are generated in this process, an arc will jump the contacts after they have opened, clearing the oscillating current. As the contacts separate further, the process is repeated until the voltage generated by the collapsing lines of flux is no longer sufficient to jump the widening gap between the contacts. This voltage then may look for another discharge path, such as interwinding arcing or other components in parallel with the inductor. Contact arcing also may occur when an inductor is switched on, if the contacts bounce open after first closing. Figure 9.23 illustrates typical contacting characteristics for energizing a relay mechanism; de-energizing of relay contacts is illustrated in Figure 9.24.

It should be noted that the ringing of an inductive circuit exposed to a transient disturbance produces not only the overshoot that most engineers are familiar with, but also a potentially damaging undershoot. This effect is illustrated in Figure 9.25. Sudden and severe polarity reversals such as the one illustrated can have damaging effects on semiconductor devices.



**Figure 9.21** The relationship (computed and measured) between utility company system voltage and switching transient peaks. Switching transients are plotted as a function of nominal operating voltages for three values of the transient tail time to half-potential. It can be seen that there is no direct linear increase in transient amplitude as the system voltage is increased.



**Figure 9.22** The mechanics of contact bounce: (a) measurement configuration; (b) representative waveforms. The waveforms shown are exaggerated to illustrate the transient effects. For clarity, the modulating effect of the ac line voltage is not shown.

### 9.3.3 Telephone System Transients

Overvoltages on telephone loops and data lines generally can be traced to the 60 Hz power system and lightning. Faults, crossed lines, and bad grounding can cause energy to be injected into or coupled onto telco circuits from utility company power lines when the cables share common poles or routing paths. Direct lightning hits to telco lines will generate huge transients on low-level audio, video, or data circuits. Buried phone company cables also are subject to damaging transients because of charge movements in the earth resulting from lightning flashes and cloud-to-loud discharge activity. Voltages can be induced in cable shield material and in the lines themselves. EMP radiation can penetrate a buried telco line in a similar manner.

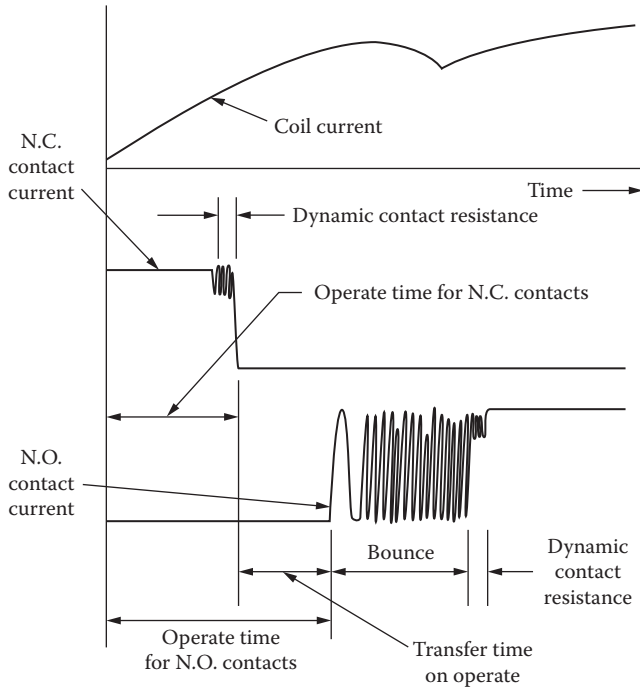


Figure 9.23 The mechanics of relay contact bounce during the energizing period.

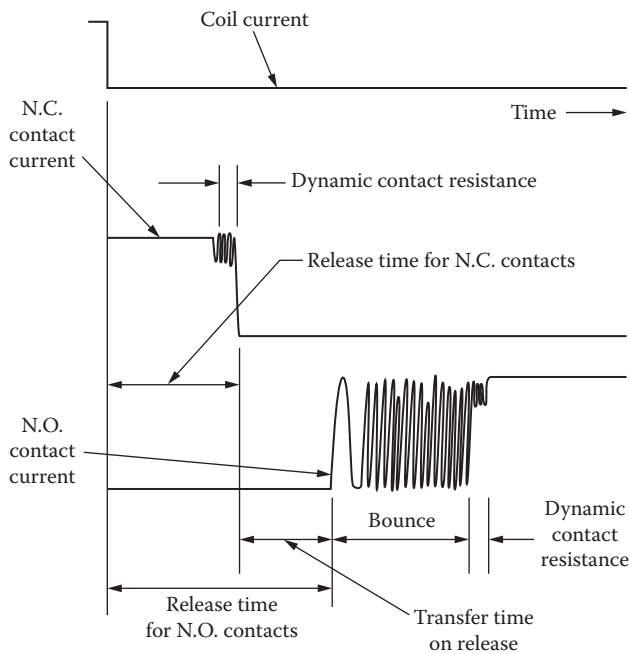


Figure 9.24 The mechanics of relay contact bounce during the de-energizing period.

Lightning or other transient currents usually travel along a telephone cable shield until dissipated, either through ground connections (in the case of pole-mounted cables) or through cable-to-earth arc-overs (in the case of buried cables). This activity usually does not cause damage to the shield material itself, but it can induce transient voltages on internal conductors, which may be harmful to central office equipment or end-user devices and systems. The characteristics of the transient that can appear at the end of a telco cable are a function of the following variables:

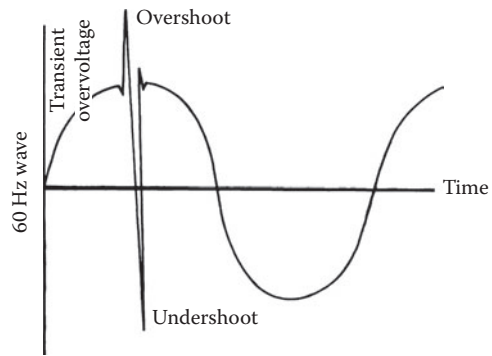
- Distance from the disturbance to the measuring point
- Type of cable used, including the jacket thickness, shielding material and thickness, and internal conductor wire size
- Amplitude and waveform of the lightning current in the cable shield

The current-generated potential along the cable shield is capacitively coupled to the internal cable pairs, so the waveform of the transient voltage observed at the measuring point (measured between ground and either conductor of a pair) closely resembles the waveform of the lightning current. The induced spike will propagate as a traveling wave in both directions along the cable from the point of injection or region of induction.

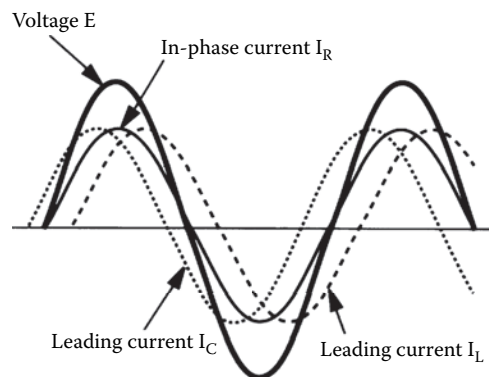
### 9.3.4 Nonlinear Loads and Harmonic Energy

Motors, incandescent lighting, and heating loads are linear in nature [5]. That is, the load impedance is essentially constant regardless of the applied voltage. As illustrated in Figure 9.26, in ac circuits, the current increases proportionately as the voltage increases, and decreases proportionately as the voltage decreases. The current is in phase with the voltage for a resistive circuit with a power factor (PF) of unity. It lags the voltage by some phase angle for the more typical partially inductive circuit (with a PF commonly between 0.80 and 0.95) and leads the voltage by some phase angle in a capacitive circuit. In either case, this current is always proportional to the voltage. For a sinusoidal voltage, the current is also sinusoidal.

A nonlinear load is one in which the load current is not proportional to the instantaneous voltage. In this case, illustrated in Figure 9.27, the load current is not continuous. Nonlinear loads typically are switched on for only a portion of the ac cycle — as in a thyristor-controlled circuit — or pulsed — as in a controlled rectifier circuit. Nonlinear load currents are nonsinusoidal, and even when the source voltage is a clean sine wave, the nonlinear load will distort the voltage wave, making it nonsinusoidal.



**Figure 9.25** The “iceberg” effect of many transient waveforms. The overshoot often is followed by an equally damaging undershoot before leveling off.



**Figure 9.26** The relationship of linear current waveforms:  $I_R$  is a purely resistive circuit current,  $I_L$  is a partially inductive (lagging) circuit current, and  $I_C$  is a partially capacitive (leading) circuit current. (From [5]. Used with permission.)

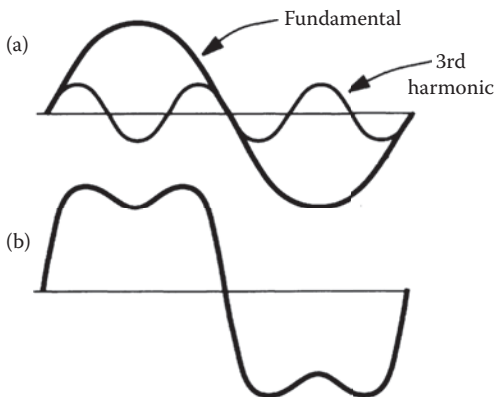
Certain deviations from the pure sine wave are the equivalent of adding one or more other pure sine waves of different frequencies. Any wave-shape, in fact, can be reproduced exactly by adding together a series of sine waves of particular frequency, amplitude, and timing, although it may require an infinite number of these waveforms. Nonsinusoidal waveforms, therefore, consist of (and can be broken down into) some finite number of pure sine waves.

The most common sine waves that distort a power system are whole number multiples of the fundamental 60 Hz power frequency, commonly known as *harmonics*. Although traditional linear loads allow voltages and currents of the fundamental frequency to appear in the power system with little or no harmonic currents, nonlinear loads can introduce significant levels of harmonics into the system. Harmonic energies combine with the fundamental to form distorted waveforms of the type shown in Figure 9.28. The amount of distortion is determined by the frequency and amplitude of the harmonic currents.

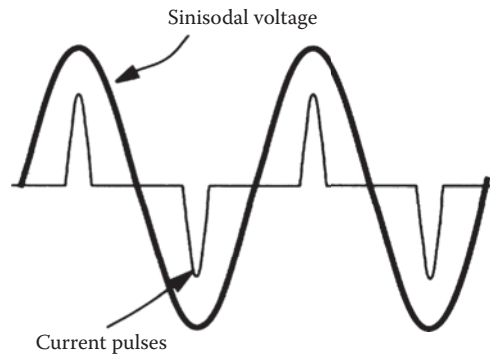
In a three-phase, four-wire system, single-phase line-to-neutral load currents flow in each phase conductor and return in the common neutral conductor. The three 60 Hz phase currents are separated by  $120^\circ$ , and for balanced three-phase linear loads, they are equal. When these currents return in the neutral, they cancel each other, adding up to zero at all points. Thus, for balanced three-phase, 60 Hz loads, neutral current is zero.

For second harmonic currents separated by  $120^\circ$ , cancellation in the neutral also is complete (see Figure 9.29), resulting in zero neutral current. This is true for all even harmonics.

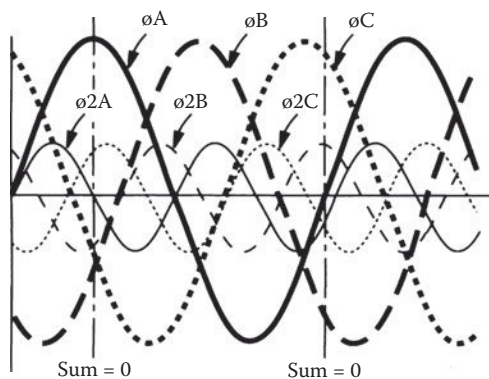
For third harmonic currents, the return currents from each of the three phases are in phase in the neutral (Figure 9.30), and so the total third harmonic neutral current is the arithmetic sum of the three individual third harmonic phase currents. This is also true for all odd multiples of the third harmonic (9<sup>th</sup>, 15<sup>th</sup>, 21<sup>st</sup>, and so on), which are the additive *zero sequence* currents.



**Figure 9.28** The addition of 60 Hz fundamental and 3<sup>rd</sup> harmonic waveshapes: (a) individual waveshapes, (b) resulting distorted waveshape. (From [5]. Used with permission.)

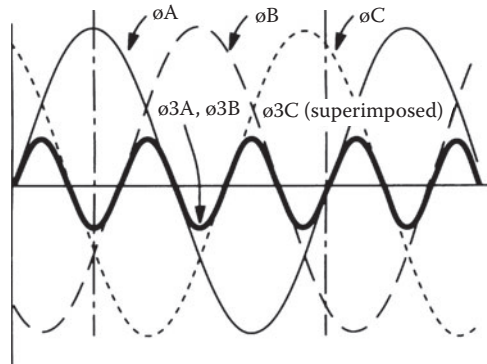


**Figure 9.27** Typical waveforms of nonlinear load current. (From [5]. Used with permission.)



**Figure 9.29** Fundamental and 2<sup>nd</sup>-harmonic currents in a three-phase, four-wire circuit. At any point, the sum of the positive (+) and negative (−) currents equals zero for the fundamental current, the 2<sup>nd</sup>-harmonic current, and — in similar fashion — all even-harmonic currents. Therefore, for balanced loads on a three-phase, four-wire system, no 60 Hz or even-harmonic currents flow in the common neutral. (From [5]. Used with permission.)

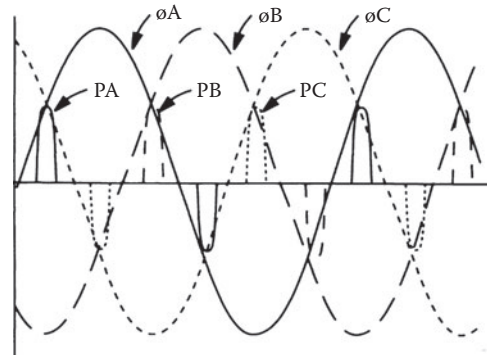
**Figure 9.30** Fundamental and 3<sup>rd</sup>-harmonic currents. Third-harmonic currents are equal and in phase (the curves are superimposed). At any point, the sum of the harmonic currents equals three times the value of any one of the currents. This also is true for all odd multiples of the 3<sup>rd</sup>-harmonic (9<sup>th</sup>, 15<sup>th</sup>, 21<sup>st</sup>, and so on). Other odd harmonics are also additive, but not fully, because they are equal but not exactly in phase. The total neutral current for other odd harmonics (5<sup>th</sup>, 7<sup>th</sup>, 11<sup>th</sup>, etc.) is more than any one harmonic phase current, but less than three times any harmonic phase current. (From [5]. Used with permission.)



Other odd harmonics (5<sup>th</sup>, 7<sup>th</sup>, 11<sup>th</sup>, 13<sup>th</sup>, and so on) add in the neutral, but the total neutral-harmonic current is somewhat less than the arithmetic sum of the three harmonic phase currents. Mathematically, the total is the vector sum of the three currents. The phase angles between the three phase currents result in partial addition and partial cancellation.

The theoretical maximum neutral current with harmonics is at least 1.73 and perhaps as much as 3.00 times the phase current. (There is dispute as to the true maximum value between these limits.)

For pulsed loads, the pulses can occur in each phase at a different time. They will return in the common neutral, but they will be separated by time; therefore, there will be no cancellation. If none of the pulses overlap, the neutral current can be three times the phase current, as illustrated in Figure 9.31.



**Figure 9.31** Fundamental and pulsed currents. The sum of the pulses in the neutral equals three times the rms value of any one phase pulse because there is little or no overlap or cancellation. The rms current in the neutral depends on each single-phase pulse rms current, and the pulse shape, frequency, and duration. (From [5]. Used with permission.)

The effects of additive harmonics in the neutral were first recognized in the National Electrical Code (NEC) many years ago, when Sec. 230-22 prohibited reduced neutral conductor size for that portion of the load consisting of discharge lighting. The effects of electronic equipment were recognized in the 1987 NEC when the prohibition in Sec. 230-22 against reducing the neutral was expanded to include loads from data processing and similar equipment.

Ratings of transformers and generators are based on the heating created by load currents of an undistorted 60 Hz sine wave. When the load currents are nonlinear and have a substantial harmonic content, they cause considerably more heating than the same number of amperes of a pure sine wave. There are several major reasons for this, including:

- Hysteresis
- Eddy currents
- Skin effects

These parameters were discussed in [Section 1.4](#).

As harmonic currents are drawn by various loads, they act on the impedance of the source, causing harmonic distortion of the source voltage. Although motors are normally linear loads, when the supply voltage has harmonic distortion, motors draw harmonic currents. These harmonic currents cause excessive motor heating from higher hysteresis and eddy-current losses in the motor laminations and skin



effect in the windings. Thus, motors supplied from sources with voltage distorted by other nonlinear loads also will overheat unless they are derated by a sufficient amount.

The solutions to overheating of transformers, generators, and motors as a result of nonlinear loads are the same as those for neutral overheating. The equipment must be derated or the harmonic content must be reduced by line filters, or both.

In addition to excessive heating, harmonic currents can cause other serious problems for generator installations. Modern generators use electronic means to regulate the output voltage, to control the speed of the engine or prime mover (and, thus, the output frequency of the generator), to parallel generators, and to share the load proportionately among the paralleled units. Many of these control devices use circuits that measure the zero crossing point of the voltage or current wave. At 60 Hz, this system works as intended, but with high harmonic content, there may be more zero crossings than normal for 60 Hz. This can cause hunting and instability in speed and frequency control, and can make the paralleling of generators difficult or impossible.

### 9.3.4.1 Harmonic Sources

Probably the largest single contributors to the problem of harmonics are the personal computer (PC), office equipment, and other sensitive electronic equipment that utilize switching-type power supplies to produce the working dc voltages they require [5]. These types of supplies generate large amounts of third-harmonic currents (180 Hz).

Switching-mode power supplies, also known simply as “switchers,” are used in most modern low-voltage electronic equipment, supplying voltages of between 3 and 15 Vdc. A simplified schematic diagram of a switching-mode supply is given in Figure 9.32. Incoming 60 Hz power is rectified at line voltage by bridge rectifier BR<sub>1</sub> and the high dc voltage is stored in capacitor C<sub>1</sub>. The control system switches the dc voltage from BR<sub>1</sub> on and off at a high frequency, which in various designs ranges from 10 to 100 kHz or higher. These high-frequency pulses are stepped down in voltage by transformer TR and rectified by diodes D<sub>1</sub> and D<sub>2</sub>. The low-voltage dc is filtered by capacitor C<sub>2</sub> and choke L<sub>2</sub>.

The ripple frequency of the dc output from the diodes is twice that of the switching frequency, ranging from 20 to 200 kHz. Because of the high switching frequency, transformer TR and the filter formed by the capacitor and choke can be small and lightweight compared to their 60 Hz equivalents. The output voltage is controlled by the switcher, eliminating the series regulator and its associated losses.

As the load draws power, the switcher takes energy stored in capacitor C<sub>1</sub>, lowering the capacitor voltage. When the voltage from rectifier BR<sub>1</sub> exceeds the voltage on C<sub>1</sub>, the rectifier delivers a pulse of current to the capacitor. The rectifier starts taking power from the source as the incoming voltage approaches the peak of the sine wave and stops taking power when the voltage from the rectifier drops below the voltage on the capacitor, long before the incoming sine wave voltage reaches zero. These current pulses are extremely nonlinear and high in harmonics.

Although switchers can be the source of noise and harmonic problems, they also have many advantages that dictate their use, including a typical overall efficiency in the neighborhood of 75%, compared to a linear supply efficiency of perhaps 50%, depending upon loading. The improved energy storage of a switching supply also offers longer ride-through — about 16 ms (one cycle) compared to about 4 ms for

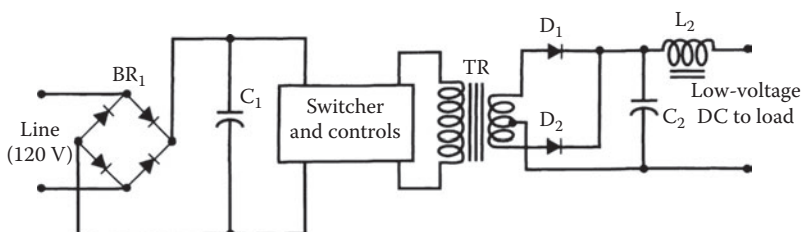


Figure 9.32 Simplified block diagram of a switching-mode power supply. (From [5]. Used with permission.)

a linear supply. Furthermore, the linear supply usually requires the input voltage to be held to within 10% of nominal, whereas the switcher can tolerate voltage dips of approximately 20%.

Although switchers constitute a major source of harmonic currents, there are many other possible sources. Depending upon the nature of the loads that predominate in a particular facility, these other sources may actually be the main contributors of harmonic currents. Such loads include:

- Fluorescent ballasts. In fluorescent lighting fixtures with conventional magnetic ballasts, the third-harmonic current content is typically in the range of 13 to 20% of the fundamental 60 Hz frequency. Electronic ballasts generate an even higher third-harmonic component, as high as 80% .
- Adjustable speed drives. For power quality considerations, adjustable speed drives can be divided into two basic groups: (1) *voltage source inverter* (VSI) drives, and (2) *current source inverter* (CSI) drives. VSIs use large capacitors in the dc link to provide constant voltage to the inverter. The inverter then chops the dc voltage to provide the variable frequency ac voltage to the motor. CSI drives, on the other hand, are used for larger horsepower applications where custom designs are justified. The dc link consists of a large choke to keep the dc current relatively constant. The inverter then chops this current waveform to provide the variable frequency ac signal to the motor.
- Static UPS systems. In static UPS systems, the incoming ac is rectified to dc, which is then inverted by pulsing circuits back to ac to obtain constant-frequency 60 or 415 Hz ac power. The rectifier voltage control is obtained with thyristors (SCRs). These are gated on (conducting) at any point in the cycle, turn off automatically as the voltage passes through zero, and are gated on again at the same point in each subsequent half-cycle. Output distortion of the UPS for a given load depends on the UPS design and output impedance. Thus, most UPS manufacturers specify the output voltage distortion of their equipment; 5% *total harmonic distortion* (THD) is typical. However, many add a disclaimer, such as “Based on linear loads.”
- Controlled rectifiers. A characteristic of all controlled rectifiers is that they are nonlinear and draw currents of high harmonic content from the source. Phase-controlled rectifiers using thyristors do not begin to conduct until gated on; they shut off at or near the zero-crossing.

### 9.3.5 Carrier Storage

Although the carrier storage phenomenon is rarely a source of serious transient disturbances, its effects should be considered in any critical application. When a silicon diode switches from a forward conduction mode to a reverse blocking state, the presence of stored carriers at the device junction can prevent an immediate cessation of current. These stored carriers have the effect of permitting current to flow in the reverse direction during a brief portion of the ac cycle.

The carrier storage current is limited only by the applied voltage and external circuit design. The current flow is brief, as carriers are removed rapidly from the junction by internal recombination and the sweeping effects of the reverse current. This removal of carriers causes the diode to revert to its blocking condition, and the sudden cessation of what can be a large reverse current may cause damaging voltage transients in the circuit if there is appreciable system inductance and if transient suppression has not been included in the system design.

The reverse current caused by carrier storage usually is not excessive in normal operation of power rectifier circuits. Carrier storage does not, in itself, constitute a hazard, especially at ac power-line frequencies. The carrier storage effect can, however, lead to complications in certain switching arrangements. For example, current will tend to “free-wheel” through rectifier diodes after the supply voltage has been removed in an inductive circuit until the stored energy has been dissipated. If the supply voltage is reapplied while this free-wheeling process is under way, some of the diodes in the circuit will be required to conduct in a forward direction, but others will be required to block. While the latter diodes are recovering from the carrier storage free-wheeling current, a short-circuit effect will be experienced by the source, causing potentially damaging surge currents.



### 9.3.6 Transient-Generated Noise

Problems can be caused in a facility by transient overvoltages not only through device failure, but also because of logic state upsets. Studies have shown that an upset in the logic of typical digital circuitry can occur with transient energy levels as low as  $1 \times 10^{-9}$  J. Such logic-state upsets can result in microcomputer latchup, lost or incorrect data, program errors, and control-system shutdown. Transient-induced noise is a major contributor to such problems.

Utility company transients, lightning, and ESD are the primary sources of random, unpredictable noise. Unless properly controlled, these sources represent a significant threat to equipment reliability. Although more predictable, other disturbance sources, such as switch contact arcing and SCR switching, also present problems for equipment users.

#### 9.3.6.1 ESD Noise

The upper frequency limit for an ESD discharge can exceed 1 GHz. Determining factors include the voltage level, relative humidity, speed of approach, and shape of the charged object. At such frequencies, circuit board traces and cables function as fairly efficient receiving antennas.

Electrical noise associated with ESD may enter electronic equipment by either conduction or radiation. In the near field of an ESD (within a few tens of centimeters), the primary type of radiated coupling can be either inductive or capacitive, depending on the impedances of the ESD source and the receiver. In the far field, electromagnetic field coupling predominates. Circuit operation is upset if the ESD-induced voltages or currents exceed typical signal levels in the system. Coupling of an ESD voltage in the near field is determined by the impedance of the circuit:

- For a high-impedance circuit, capacitive coupling will dominate and ESD-induced voltages will be the major problem.
- For a low-impedance circuit, inductive coupling will dominate and ESD-induced currents will be the major problem.

#### 9.3.6.2 Contact Arcing

Switch contact arcing and similar repetitive transient-generating operations can induce significant broadband noise into an electrical system. Noise generated in this fashion is best controlled at its source, almost always an inductive load. Noise can travel through power lines and create problems for microcomputer equipment, either through direct injection into the system power supply, or through coupling from adjacent cables or printed wiring board (PWB) traces.

#### 9.3.6.3 SCR Switching

SCR power controllers are a potential source of noise-induced microcomputer problems. Each time an SCR is triggered into its active state in a resistive circuit, the load current goes from zero to the load-limited current value in less than a few microseconds. This step action generates a broadband spectrum of energy, with an amplitude inversely proportional to frequency. Electronic equipment using full-wave SCR control in a 60 Hz circuit can experience such noise bursts 120 times a second.

In an industrial environment, where various control systems may be spaced closely, electrical noise can cause latchup problems or incorrect data in microcomputer equipment, or interaction between SCR firing units in machine controllers. Power-line cables within a facility can couple noise from one area of a plant to another, further complicating the problem. The solution to the SCR noise problem is found by looking at both the source of the interference and the susceptible hardware. The use of good transient-suppression techniques in the application of SCR power controllers will eliminate noise generation in all but the most critical of applications.

## 9.4 References

1. Berger, K., "Blitzstorm-Parameter von Aufwärtsblitzen," *Bull. Schweiz. Electrotech.*, Ver., Vol. 69, pp. 353–360, 1978.
2. Uman, M. A., "Natural and Artificially Initiated Lightning and Lightning Test Standards," *Proceedings of the IEEE*, Vol. 76, No. 12, IEEE, New York, December 1988.
3. Technical staff, Military/Aerospace Products Division, *The Reliability Handbook*, National Semiconductor, Santa Clara, CA, 1987.
4. Cherniak, S., "A Review of Transients and Their Means of Suppression," Motorola Semiconductor Application Note AN843/D, Rev. 1, Motorola, Phoenix, AZ, 1991.
5. DeDad, J. A., et al., "Nonlinear Loads and Harmonics," in *Practical Guide to Quality Power for Sensitive Electronic Equipment*, PRIMEDIA Intertec, Overland Park, KS, pp. 45–49, 1994.

## 9.5 Bibliography

- Bishop, D., "Lightning Devices Undergo Tests at Florida Airports," *Mobile Radio Technology*, PRIMEDIA Intertec, Overland Park, KS, May 1990.
- Bishop, D., "Lightning Sparks Debate: Prevention or Protection?" *Mobile Radio Technology*, PRIMEDIA Intertec, Overland Park, KS, January 1989.
- Block, R., "Dissipation Arrays: Do They Work?," *Mobile Radio Technology*, PRIMEDIA Intertec, Overland Park, KS, April 1988.
- Block, R., "The Grounds for Lightning and EMP Protection," PolyPhaser Corp., Gardnerville, NV, 1987. Defense Civil Preparedness Agency, *EMP and Electric Power Systems*, Publication TR-61-D, U.S. Department of Commerce, National Bureau of Standards, Washington, DC, July 1973.
- Defense Civil Preparedness Agency, *EMP Protection for Emergency Operating Centers*, Federal Information Processing Standards Publication no. 94, Guideline on Electrical Power for ADP Installations, U.S. Department of Commerce, National Bureau of Standards, Washington, DC, 1983.
- Drabkin, M., and R. Carpenter, Jr., "Lightning Protection Devices: How Do They Compare?," *Mobile Radio Technology*, PRIMEDIA Intertec, Overland Park, KS, October 1988.
- Fink, D., and D. Christiansen, (Eds.) *Electronics Engineers' Handbook*, 3rd ed., McGraw-Hill, New York, 1989.
- Goldstein, M., and P. D. Speranza, "The Quality of U.S. Commercial AC Power," *Proceedings of the IEEE*, IEEE, New York, 1982.
- Jay, F., Ed., *IEEE Standard Directory of Electrical and Electronics Terms*, 3rd ed., IEEE, New York, 1984.
- Jordan, C. (Ed.), *Reference Data for Engineers: Radio, Electronics, Computer, and Communications*, 7th ed., Howard W. Sams, Indianapolis, IN, 1985.
- Kaiser, B. A., "Can You Really Fool Mother Nature?" *Cellular Business*, PRIMEDIA Intertec, Overland Park, KS, March 1989.
- Kaiser, B. A., "Straight Talk on Static Dissipation," *Proceedings of ENTELEC 1988*, Energy Telecommunications and Electrical Association, Dallas, TX, 1988.
- Key, Lt. T., "The Effects of Power Disturbances on Computer Operation," IEEE Industrial and Commercial Power Systems Conference paper, Cincinnati, OH, June 7, 1978.
- Martzloff, F. D., "The Development of a Guide on Surge Voltages in Low-Voltage AC Power Circuits," 14th Electrical/Electronics Insulation Conference, IEEE, Boston, MA, October 1979.
- Nott, R., "The Sources of Atmospheric Energy," *Proceedings of the SBE National Convention and Broadcast Engineering Conference*, Society of Broadcast Engineers, Indianapolis, IN, 1987.
- Technical staff, "Voltage Transients and the Semiconductor," *The Electronic Field Engineer*, pp. 37–40, March/April 1979.
- Technical staff, Military/Aerospace Products Division, *The Reliability Handbook*, National Semiconductor, Santa Clara, CA, 1987.
- Ulman, M. A., *The Lightning Discharge*, Academic Press, Orlando, FL, 1987.
- Whitaker, C., *Electronic Systems Maintenance Handbook*, 2nd ed., CRC Press, Boca Raton, FL, 2001.

# 10

## Power Disturbance Characterization

---

### 10.1 Introduction

---

Short-term ac voltage disturbances can be classified into four major categories, as illustrated in [Figure 10.1](#). The categories are defined according to peak value and duration:

- *Voltage surge*: An increase of 10 to 35% above the nominal line voltage for a period of 16 ms to 30 s.
- *Voltage sag*: A decrease of 10 to 35% below the nominal line voltage for a period of 16 ms to 30 s.
- *Transient disturbance*: A voltage pulse of high energy and short duration impressed upon the ac waveform. The overvoltage pulse can be 1 to 100 times the nominal ac potential and can last up to 15 ms. Rise times measure in the nanosecond range.
- *Momentary power interruption*: A decrease to zero voltage of the ac power-line potential, lasting from 33 to 133 ms. Longer-duration interruptions are considered power outages.

Voltage surges and sags occasionally result in operational problems for equipment on-line, but automatic protection or correction circuits generally take appropriate actions to ensure that there is no equipment damage. Such disturbances can, however, garble computer system data if the disturbance transition time (the rise/fall time of the disturbance) is sufficiently fast. System hardware also may be stressed if there is only a marginal power supply reserve or if the disturbances are frequent.

Momentary power interruptions can cause a loss of volatile memory in computer-driven systems and place severe stress on hardware components, especially if the ac supply is allowed to surge back automatically without soft-start provisions. Successful system reset may not be accomplished if the interruption is sufficiently brief.

Although voltage sags, surges, and momentary interruptions can cause operational problems for equipment used today, the possibility of complete system failure because of one of these mechanisms is relatively small. The greatest threat to the proper operation of electronic equipment rests with transient overvoltage disturbances on the ac line. Transients are difficult to identify and difficult to eliminate. Many devices commonly used to correct sag and surge conditions, such as ferroresonant transformers or motor-driven autotransformers, are of limited value in protecting a load from high-energy, fast-rise-time disturbances.

In the computer industry, research has shown that a significant number of unexplained problems resulting in disallowed states of operation actually are caused by transient disturbances on the utility feed. With the increased use of microcomputers in industry, this consideration cannot be ignored. Because of the high potential that transient disturbances typically exhibit, they not only cause data and program errors, but also can damage or destroy electric components. This threat to electronic equipment involves sensitive integrated circuits and many other common devices, such as capacitors, transformers, rectifiers, and power semiconductors. [Figure 10.2](#) illustrates the vulnerability of common components to high-energy pulses. The effects of transient disturbances on electronic devices are often cumulative, resulting in gradual deterioration and, ultimately, catastrophic failure.

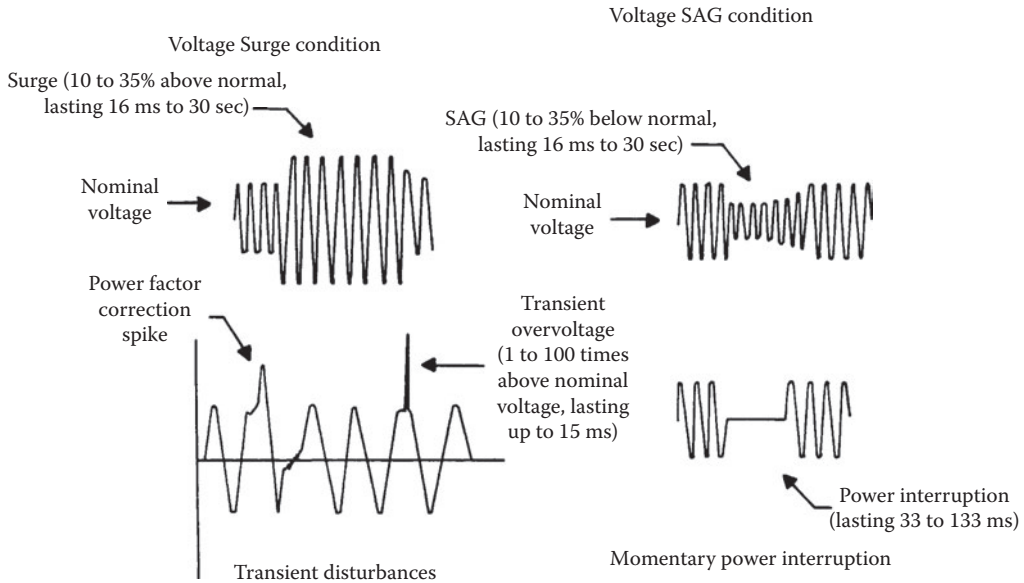


Figure 10.1 The four basic classifications of short-term power-line disturbances.

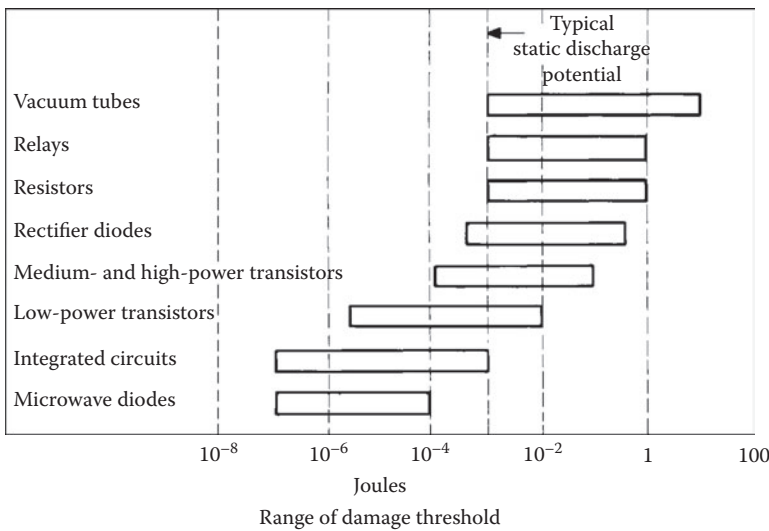


Figure 10.2 An estimation of the susceptibility of common electric devices to damage from transient disturbances. The vertical line marked “discharge” represents the energy level of a discharge that typically can be generated by a person who touches a piece of equipment after walking across a carpeted floor.

## 10.2 Standards of Measurement

Various test procedures and standards have been developed to enable system designers to evaluate the effectiveness of proposed protective measures. These range from simulation of lightning currents, voltages, and electric and magnetic fields to the generation of typical lightning-induced current and voltage transients expected to appear at the terminals of electronic equipment. Damaging effects can be divided into two basic categories:

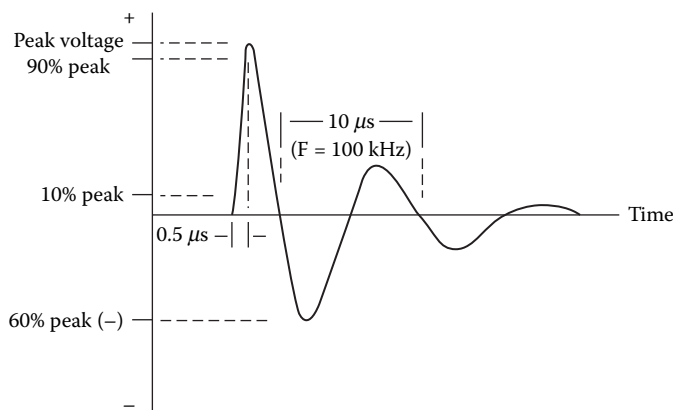
- **Direct effects:** Damage to metal and insulator surfaces, and ignition of flammable vapors resulting from direct lightning attachment.
- **Indirect effects:** Damage resulting from the currents and voltages induced in internal circuits by lightning that has struck the exterior of a structure or a vehicle.

Because it is difficult to assess the threat posed by transient disturbances without guidelines on the nature of transients in ac power systems, a number of separate standards have been developed for individual component groups. The best known was developed by a working group of the Institute of Electrical and Electronics Engineers (IEEE) to simulate indirect lightning effects. IEEE suggested two waveforms, one unidirectional and the other oscillatory, for measuring and testing transient suppression components and systems in ac power circuits with rated voltages of up to 1 kV rms line-to-ground. The guidelines also recommend specific source impedance or short-circuit current values for transient analysis.

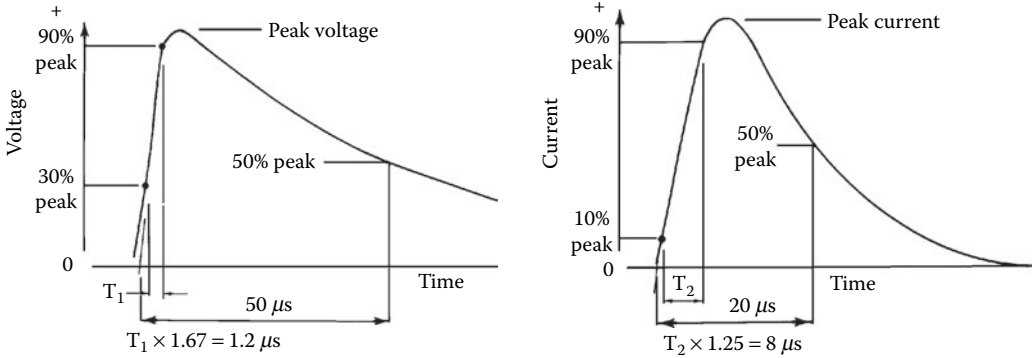
The voltage and current amplitudes, waveshapes, and source impedance values suggested in the American National Standards Institute/IEEE guide (ANSI/IEEE standard C62.41-1980) were designed to approximate the vast majority of high-level transient disturbances, but were not intended to represent worst-case conditions — a difficult parameter to predict. The timing of a transient overvoltage with respect to the power line waveform is also an important parameter in the examination of ac disturbances. Certain types of semiconductors exhibit failure modes that are dependent on the position of a transient on the sine wave.

Figure 10.3 shows the ANSI/IEEE representative waveform for an indoor-type spike (for 120 to 240 Vac systems). Field measurements, laboratory observations, and theoretical calculations have shown that most transient disturbances in low-voltage indoor ac power systems have oscillatory waveshapes, instead of the unidirectional wave most often thought to represent a transient overvoltage. The oscillatory nature of the indoor waveform is the result of the natural resonant frequencies of the ac distribution system. Studies by the IEEE show that the oscillatory frequency range of such disturbances extends from 30 Hz to 100 kHz, and that the waveform changes, depending upon where it is measured in the power distribution system.

The waveform shown in Figure 10.3 is the result of extensive study by the IEEE and other independent organizations of various ac power circuits. The representative waveshape for 120 and 240 V systems is described as a 0.5  $\mu$ s to 100 kHz ring wave. This standard indoor spike has a rise time of 0.5  $\mu$ s, then decays while oscillating at 100 kHz. The amplitude of each peak is approximately 60% of the preceding peak.



**Figure 10.3** The suggested ANSI/IEEE indoor-type transient overvoltage test waveform (0.5  $\mu$ s to 100 kHz ring wave, open-circuit voltage).

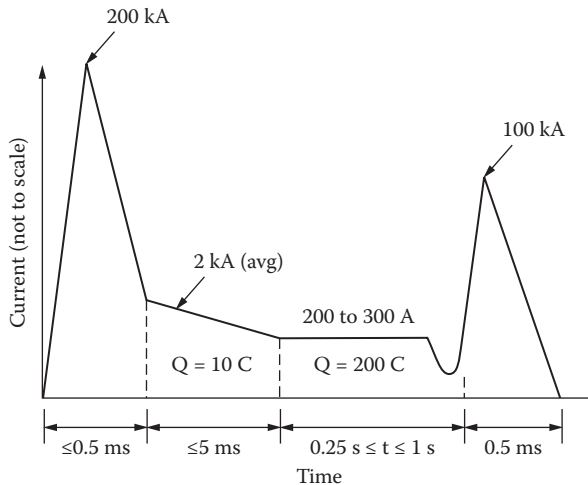


**Figure 10.4** The unidirectional waveshape for outdoor-type transient overvoltage test analysis based on ANSI Standard C62.1: (a) open-circuit waveform, (b) discharge current waveform.

Figure 10.4 shows the ANSI/IEEE representative waveforms for an outdoor-type spike. The classic lightning overvoltage pulse has been established at a 1.2/50  $\mu s$  waveshape for a voltage wave and an 8/20  $\mu s$  waveshape for a current wave. Accordingly, the ANSI/IEEE standard waveshape is defined as 1.2/50  $\mu s$  open-circuit voltage (voltage applied to a high-impedance device), and 8/20  $\mu s$  discharge current (current in a low-impedance device).

The test waveshapes, although useful in the analysis of components and systems, are not intended to represent all transient patterns seen in low-voltage ac circuits. Lightning discharges can cause oscillations, reflections, and other disturbances in the utility company power system that can appear at the service drop entrance as decaying oscillations.

Unfortunately, most lightning disturbance standard waveforms address one or two characteristics of a discharge. Furthermore, standard waveforms are intended to represent typical events, not worst-case events. In testing to determine the immunity of a system to a direct lightning strike, a conservative approach is generally taken, in that the characteristics of a relatively severe flash are adopted. Figure 10.5 shows a test waveform specified for aerospace vehicles (MIL-STD-1757A). The current waveform includes one initial and one subsequent stroke, between which flows continuing current. Peak currents are 200 kA for the first stroke and 100 kA for the subsequent stroke. The total charge transfer is in excess of 200 C.



**Figure 10.5** Lightning test current waveform specified in MIL STD-1757A. (After [1].)

### 10.2.1 Assessing the Threat

High-speed digital ac line monitoring instruments provide a wealth of information on the quality of incoming utility power at a facility. Such instruments have changed the business of assessing the threat posed by unprocessed ac from an educated guess to a fine science. Sophisticated monitoring equipment can give the user a complete, detailed look at what is coming in from the power company. Such monitoring devices provide data on the problems that can be expected when operating data processing, communications, or other sensitive electronic equipment from an unprotected ac line. Power-quality surveys are available from a number of consulting firms and power-conditioning companies. The typical procedure involves installing a sophisticated voltage-monitoring unit at the site to be used for a period of several weeks to several months. During that time, data is collected on the types of disturbances the load equipment is likely to experience.

The type of monitoring unit used is of critical importance. It must be a high-speed system that stores disturbance data in memory and delivers a printout of the data on demand. Conventional chart recorders are too slow and lack sufficient sensitivity to accurately show short-duration voltage disturbances. Chart recorders can confirm the presence of long-term surge and sag conditions, but provide little useful data on transients.

### 10.2.2 Fundamental Measurement Techniques

Most power system measurements involve characterizing fundamental parameters. These include voltage, phase, and frequency. Most other tests consist of measuring these fundamental parameters and displaying the results in combination by using some convenient format. Measurements are made on equipment and systems to check performance under specified conditions and to assess suitability for use in a particular application. The measurements can be used to verify specified system performance or as a way of comparing several pieces of equipment for use in a system. Measurements can also be used to identify components in need of adjustment or repair.

Measurement of voltage is fundamental to ac operation. Voltage can be measured either in absolute terms or in relative terms. Power demand is an example of an absolute level measurement; it does not require any reference. Gain and loss are examples of relative, or ratio, measurements.

Distortion measurements are a way of quantifying the amount of unwanted components added to a signal by a piece of equipment. The most common technique is total harmonic distortion (THD), but others can be used. Distortion measurements express the amount of unwanted signal components relative to the desired signal, usually as a percentage or decibel value. This is another example of multiple level measurements that are combined to give a new measurement figure.

The simplest definition of a level measurement is the alternating current amplitude at a particular place in the system under test. However, in contrast to direct current measurements, there are many ways of specifying ac voltage. The most common methods include:

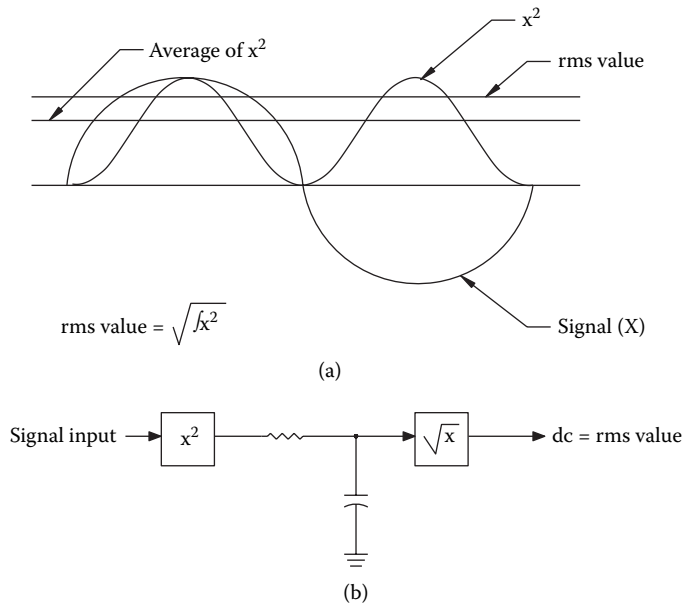
- Root-mean-square
- Average response
- Peak

#### 10.2.2.1 Root-Mean-Square

The rms technique measures the effective power of the ac signal. It specifies the value of the dc equivalent that would dissipate the same power if either were applied to a load resistor. This process is illustrated in [Figure 10.6](#). The input signal is squared, and the average value is found. This is equivalent to finding the average power. The square root of this value is taken to transfer the signal from a power value back to a voltage. For the case of a sine wave, the rms value is 0.707 of its maximum value.

Assume that the signal is no longer a sine wave, but rather a sine wave and several harmonics. If the rms amplitude of each harmonic is measured individually and added, the resulting value will be the same





**Figure 10.6** Root-mean-square (rms) voltage measurements: (a) the relationship of rms and average values, (b) the rms measurement circuit.

as an rms measurement on the signals together. Because rms voltages cannot be added directly, it is necessary to perform an rms addition. Each voltage is squared, and the squared values are added as follows:

$$V_{rms\,total} = \sqrt{V_{rms1}^2 + V_{rms2}^2 + V_{rms3}^2 + \dots + V_{rmsn}^2} \quad (10.1)$$

Note that the result is not dependent on the phase relationship of the signal and its harmonics. The rms value is determined completely by the amplitude of the components. This mathematical predictability is useful in practical applications of level measurement, enabling measurements made at different places in a system to be correlated. It is also important in correlating measurements with theoretical calculations.

### 10.2.2.2 Average-Response Measurement

The average-responding voltmeter measures ac voltage by rectifying it and filtering the resulting waveform to its average value, as shown in Figure 10.7. This results in a dc voltage that can be read on a standard dc voltmeter. As shown in the figure, the average value of a sine wave is 0.637 of its maximum amplitude. Average-responding meters are usually calibrated to read the same as an rms meter for the case of a single sine wave signal. This results in the measurement being scaled by a constant  $K$  of 0.707/0.637, or 1.11. Meters of this type are called *average-responding, rms calibrated*. For signals other than sine waves, the response will be different and hard to predict.

If multiple sine waves are applied, the reading will depend on the phase shift between the components and will no longer match the rms measurement. A comparison of rms and average-response measurements is made in Figure 10.8 for various waveforms. If the average readings are adjusted as described previously to make the average and rms values equal for a sine wave, all the numbers in the *average* column should be increased by 11.1%, whereas the *rms-average* numbers are reduced by 11.1%.

### 10.2.2.3 Peak-Response Measurement

Peak-responding meters measure the maximum value that the ac signal reaches as a function of time. This approach is illustrated in Figure 10.9. The signal is full-wave-rectified to find its absolute value and then passed through a diode to a storage capacitor. When the absolute value of the voltage rises above the



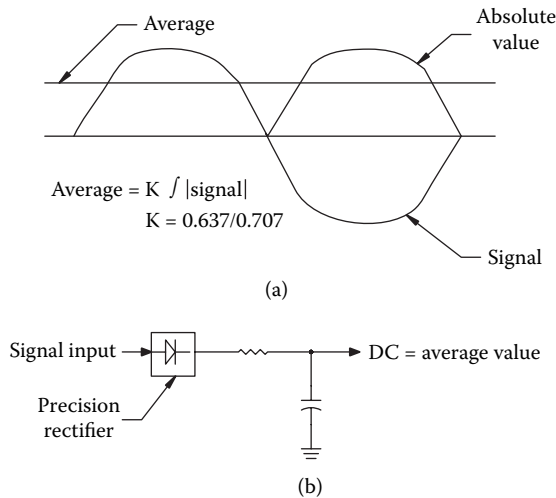


Figure 10.7 Average voltage measurements: (a) illustration of average detection, (b) average measurement circuit.

Waveform	rms	Average	rms average	Crest factor
<p>Sine wave</p>	$\frac{V_m}{\sqrt{2}}$ $0.707 V_m$	$\frac{2}{\pi} V_m$ $0.637 V_m$	$\frac{\pi}{2\sqrt{2}} = 1.111$	$\sqrt{2} = 1.414$
<p>Square wave</p>	$V_m$	$V_m$	$1$	$1$
<p>Triangular wave or sawtooth wave</p>	$\frac{V_m}{\sqrt{3}}$	$\frac{V_m}{2}$	$\frac{2}{\sqrt{3}} = 1.155$	$\sqrt{3} = 1.732$

Figure 10.8 Comparison of rms and average voltage characteristics.

value stored on the capacitor, the diode will conduct and increase the stored voltage. When the voltage decreases, the capacitor will maintain the old value. Some means for discharging the capacitor is required to allow measuring a new peak value. In a true peak detector, this is accomplished by a solid-state switch. Practical peak detectors usually include a large value resistor to discharge the capacitor gradually after the user has had a chance to read the meter.

The ratio of the true peak to the rms value is called the *crest factor*. For any signal but an ideal square wave, the crest factor will be greater than 1, as demonstrated in Figure 10.10. As the measured signal become more peaked, the crest factor increases.

The *peak-equivalent sine* is another method of specifying waveform amplitude. This value is the rms level of a sine wave having the same peak-to-peak amplitude as the signal under consideration. This is the peak value of the waveform scaled by the correction factor 1.414, corresponding to the peak-to-rms ratio of a sine wave. This technique is useful when specifying test levels of waveforms in distortion measurement.

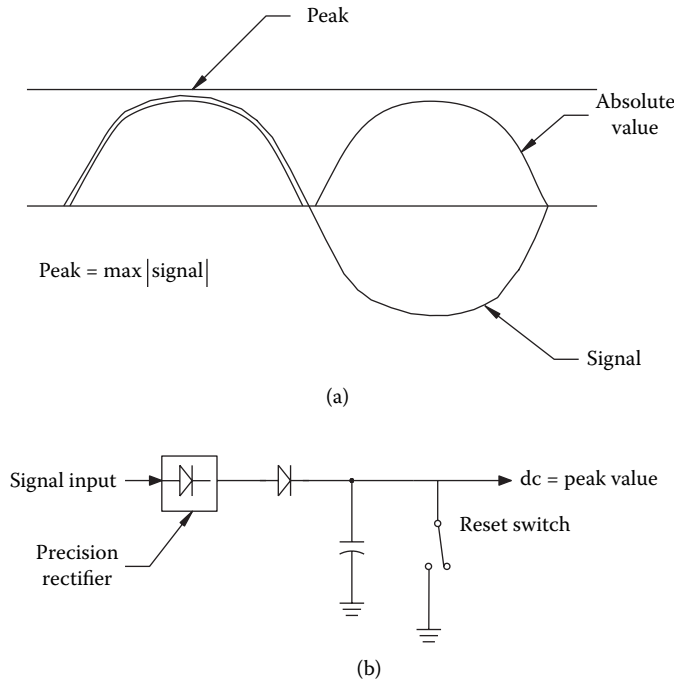


Figure 10.9 Peak voltage measurements: (a) illustration of peak detection, (b) peak measurement circuit.

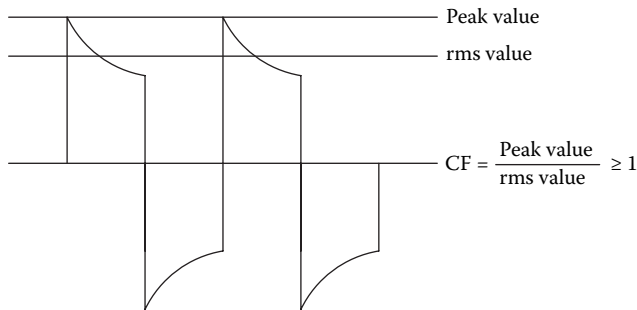


Figure 10.10 The crest factor of ac waveforms.

### 10.2.2.4 Meter Accuracy

Accuracy is a measure of how well an instrument quantifies a signal at a midband frequency. This sets a basic limit on the performance of the meter in establishing the absolute amplitude of a waveform. It also is important to look at the flatness specification to see how well this performance is maintained with changes in frequency. Flatness describes how well the measurements at any other frequency track those at the reference.

Meters often have a specification on accuracy that changes with voltage range, being most accurate only in the range in which the instrument was calibrated. A meter with 1% accuracy on the 2 V range and 1% accuracy per step would be 3% accurate on the 200 V scale. In many instruments, an additional accuracy derating is given for readings as a% age of full scale, making readings at less than full scale less accurate.

### 10.2.3 Digital Measurement Instruments

Power quality monitors are sophisticated instruments that can not only identify ac power problems, but also provide the following useful supplementary data, including:

- Ambient temperature
- Relative humidity
- Presence of radio frequency interference (RFI)
- Sample voltage monitoring for ac and dc test points
- Harmonic distortion content of the ac input signal

Digital technology offers a number of significant advantages beyond the capabilities of analog instruments. Digital ac line monitors can store in memory the signal being observed, permitting in-depth analysis impossible with previous technologies. Because the waveform resides in memory, the data associated with the waveform can be transferred to a remote computer for real-time processing, or for processing at a later time.

The *digital storage oscilloscope* (DSO) is the forerunner of most digital ac line monitors. DSO technology forms the basis for most monitoring instruments. Figure 10.11 shows a block diagram of a DSO. Instead of being amplified and applied directly to the deflection plates of a cathode ray tube (CRT), the waveform first is converted into a digital representation and stored in memory. To reproduce the waveform on the CRT, the data is sequentially read and converted back into an analog signal for display.

The analog-to-digital (A/D) converter transforms the input analog signal into a sequence of digital bits. The amplitude of the analog signal, which varies continuously in time, is sampled at preset intervals. The analog value of the signal at each sample point is converted into a binary number. This *quantization* process is illustrated in Figure 10.12. The sample rate of a digital oscilloscope must be greater than two times the highest frequency to be measured. The higher the sampling rate relative to the input signal, the greater the measurement accuracy. A sample rate ten times the input signal is sufficient for most applications. This rule of thumb applies for single-shot signals, or signals that are changing constantly. The sample rate also can be expressed as the *sampling interval*, or the period of time between samples. The sample interval is the inverse of the sampling frequency.

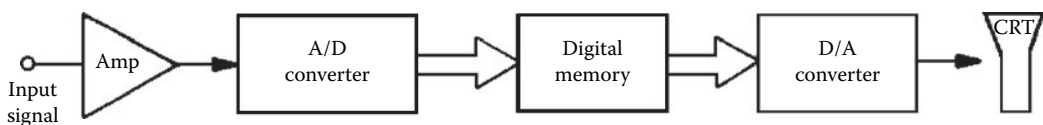


Figure 10.11 Simplified block diagram of a digital storage oscilloscope.

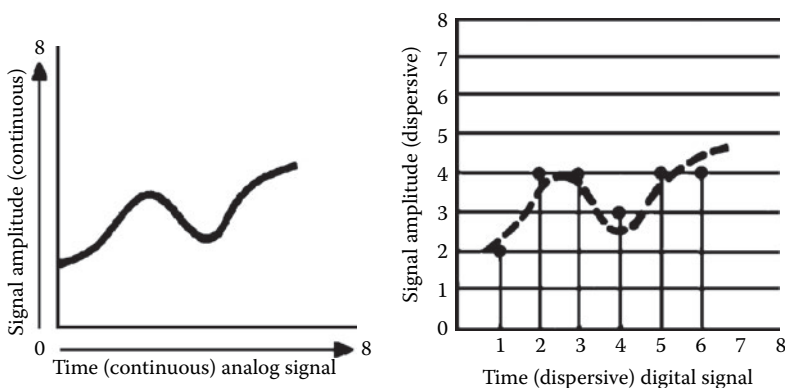


Figure 10.12 Illustration of the quantization process.

## 10.2.4 Digital Monitor Features

Advanced components and construction techniques have led to lower costs for digital instruments as well as higher performance. Digital monitors can capture and analyze transient signals from any number of sources. Automated features reduce testing and troubleshooting costs through the use of recallable instrument setups, direct parameter readout, and unattended monitoring. Digital monitors offer the following features:

- High resolution (determined by the quality of the analog-to-digital converter).
- Memory storage of digitized waveforms.
- Automatic setup for repetitive signal analysis. For complex multichannel configurations that are used often, front-panel storage/recall can save dozens of manual selections and adjustments. When multiple memory locations are available, multiple front-panel setups can be stored to save even more time.
- Auto-ranging. Many instruments will adjust automatically for optimum sweep, input sensitivity, and triggering. The instrument's microprocessor automatically configures the front panel for optimum display. Such features permit the operator to concentrate on making measurements, rather than adjusting the instrument.
- Instant hardcopy output from printers and plotters.
- Remote programmability via GPIB or dial-up modem (including the Internet) for automated test applications.
- Trigger flexibility. Single-shot digitizing monitors capture transient signals and allow the user to view the waveform that preceded the trigger point. Figure 10.13 illustrates the use of pre-/post-trigger for waveform analysis.
- Signal analysis. Intelligent systems can make key measurements and comparisons. Display capabilities include voltage peak, mean voltage, rms value, rise time, fall time, and frequency.

Digital memory storage offers a number of additional benefits, including:

- Reference memory. A previously acquired waveform can be stored in memory and compared with a sampled waveform. This feature is especially useful for identifying the source of a transient disturbance. Because certain transients have a characteristic "signature" waveform, it is possible to identify the source of a transient by examining an image of the disturbance on a CRT or suitable device. Nonvolatile battery-backed memory permits reference waveforms to be transported to field sites.
- Simple data transfers to a host computer for analysis or archive.
- Local data analysis through the use of a built-in microprocessor.
- Cursors capable of providing a readout of delta and absolute voltage and time.
- Full bandwidth capture of long-duration waveforms, thus permitting storage of all the signal details. The waveform can be expanded after capture to expose the details of a particular section.

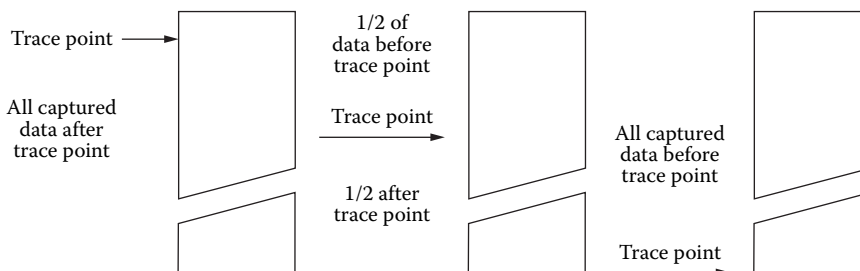


Figure 10.13 The use of a pre-/posttrigger function for waveform analysis.

## 10.3 Reliability Considerations

---

Electrical energy is transmitted from the point of generation to end users through a highly complex transmission and control system. This network consists of a grid of conductors with numerous embedded components. A typical system may consist of thousands of nodes. The network is further complicated by the interconnection of individual systems. These interconnected systems must be capable of supplying energy despite diverse and challenging physical conditions. Detailed reliability analysis is required to provide an acceptable level of performance to customers.

It is not uncommon for a utility system to experience load swings of as much as 150 MW/min, mainly the result of changing heavy industrial loads. Such fluctuations introduce a host of challenges to reliability engineers. Primary design requirements include:

- The ability to handle large, constantly changing load demands from customers.
- A strong power source to provide for high inrush currents typically experienced at industrial plants.
- Rapid and effective fault isolation. Failures in one part of the system should have minimal effect on other portions of the network.

Utility companies are meeting these goals with improved reliability analysis, more operating reserve, and computerized control systems. Rapid response to load changes and fault conditions is necessary to ensure reliable service to customers. Improved telemetry systems provide system controllers with more accurate information on the state of the network, and advanced computer control systems enable split-second decisions that minimize service disruptions.

## 10.4 Reference

---

1. Ulman, M. A., "Natural and Artificially Initiated Lightning and Lightning Test Standards," *Proceedings of the IEEE*, IEEE, New York, NY, vol. 76, no. 12, December 1988.

## 10.5 Bibliography

---

- Allen, G., and D. Segall, "Monitoring of Computer Installations for Power Line Disturbances," *Proceedings of the IEEE Power Engineering Society*, IEEE, New York, 1974.
- Breya, M., "New Scopes Make Faster Measurements," *Mobile Radio Technology*, PRIMEDIA Intertec, Overland Park, KS, November 1988.
- Defense Civil Preparedness Agency, *EMP Protection for Emergency Operating Centers*, Federal Information Processing Standards Publication No. 94, Guideline on Electrical Power for ADP Installations, U.S. Department of Commerce, National Bureau of Standards, Washington, DC, 1983.
- Fink, D., and D. Christiansen (Eds.), *Electronics Engineers' Handbook*, 3rd ed., McGraw-Hill, New York, 1989.
- Goldstein, M., and P. D. Speranza, "The Quality of U.S. Commercial AC Power," *Proceedings of the IEEE*, IEEE, New York, 1982.
- Harris, B., "The Digital Storage Oscilloscope: Providing the Competitive Edge," *Electronic Servicing & Technology*, Intertec Publishing, Overland Park, KS, June 1988.
- Harris, B., "Understanding DSO Accuracy and Measurement Performance," *Electronic Servicing & Technology*, Intertec Publishing, Overland Park, KS, April 1989.
- Hoyer, M., "Bandwidth and Rise Time: Two Keys to Selecting the Right Oscilloscope," *Electronic Servicing & Technology*, Intertec Publishing, Overland Park, KS, April 1990.
- Jay, F. (Ed.), *IEEE Standard Directory of Electrical and Electronics Terms*, 3rd ed., IEEE, New York, 1984.
- Jordan, E. C. (Ed.), *Reference Data for Engineers: Radio, Electronics, Computer, and Communications*, 7th ed., Howard W. Sams, Indianapolis, IN, 1985.

- Key, Lt. T., "The Effects of Power Disturbances on Computer Operation," IEEE Industrial and Commercial Power Systems Conference paper, Cincinnati, OH, June 7, 1978.
- Martzloff, F. D., "The Development of a Guide on Surge Voltages in Low-Voltage AC Power Circuits," 14<sup>th</sup> Electrical/Electronics Insulation Conference, IEEE, Boston, MA, October 1979.
- Montgomery, S., "Advances in Digital Oscilloscopes," *Broadcast Engineering*, PRIMEDIA Intertec, Overland Park, KS, November 1989.

# Power System Protection Methods

---

## 11.1 Introduction

---

Utility companies make a good-faith attempt to deliver clean, well-regulated power to their customers. Most disturbances on the ac line are beyond the control of the utility company. Large load changes imposed by customers on a random basis, PF correction switching, lightning, and accident-related system faults all combine to produce an environment in which tight control over ac power quality is difficult to maintain. Therefore, the responsibility for ensuring ac power quality must rest with the users of sensitive equipment.

The selection of a protection method for a given facility is as much an economic question as it is a technical one. A wide range of power-line conditioning and isolation equipment is available. A logical decision about how to proceed can be made only with accurate, documented data on the types of disturbances typically found on the ac power service to the facility. The protection equipment chosen must be matched to the problems that exist on the line. Using inexpensive basic protectors may not be much better than operating directly from the ac line. Conversely, the use of a sophisticated protector designed to shield the plant from every conceivable power disturbance may not be economically justifiable.

Purchasing transient-suppression equipment is only one element in the selection equation. Consider the costs associated with site preparation, installation, and maintenance. Also consider the operating efficiency of the system. Protection units that are placed in series with the load consume a certain amount of power and, therefore, generate heat. These considerations may not be significant, but they should be taken into account. Prepare a complete life-cycle cost analysis of the protection methods proposed. The study may reveal that the long-term operating expense of one system outweighs the lower purchase price of another.

The amount of money a facility manager is willing to spend on protection from utility company disturbances generally depends on the engineering budget and how much the plant has to lose. Spending \$250,000 on systemwide protection for a highly computerized manufacturing center is easily justified. At smaller operations, justification may not be so easy.

## 11.2 The Key Tolerance Envelope

---

The susceptibility of electronic equipment to failure because of disturbances on the ac power line has been studied by many organizations. The benchmark study was conducted by the Naval Facilities Engineering Command (Washington, DC). The far-reaching program, directed from 1968 to 1978 by Lt. Thomas Key, identified three distinct categories of recurring disturbances on utility company power systems. As shown in [Table 11.1](#), it is not the magnitude of the voltage, but the duration of the disturbance that determines the classification.

In the study, Key found that most data processing (DP) equipment failure caused by ac line disturbances occurred during bad weather, as shown in [Table 11.2](#). According to a report on the findings, the incidence of thunderstorms in an area can be used to predict the number of failures. The type of power-transmission system used by the utility company also was found to affect the number of disturbances observed on power company lines ([Table 11.3](#)). For example, an analysis of utility system problems in Washington, DC, Norfolk, VA, and Charleston, SC, demonstrated that underground power-distribution systems experienced one-third fewer failures than overhead lines in the same areas. Based on his research, Key developed the “recommended voltage tolerance envelope” shown in [Figure 11.1](#). The design goals illustrated are recommendations to computer manufacturers for implementation in new equipment.

**Table 11.1** Types of Voltage Disturbances Identified in the Key Report (*After* [1].)

Parameter	Type 1	Type 2	Type 3
Definition	Transient and oscillatory overvoltage	Momentary undervoltage or overvoltage	Power outage
Causes	Lightning, power network switching, operation of other loads	Power system faults, large load changes, utility company equipment malfunctions	Power system faults, unacceptable load changes, utility equipment malfunctions
Threshold (1)	200–400% of rated rms voltage or higher (peak instantaneous above or below rated rms)	Below 80–85% and above 110% of rated rms voltage	Below 80–85% of rated rms voltage
Duration	Transients 0.5–200 $\mu$ s wide and oscillatory up to 16.7 ms at frequencies of 200 Hz to 5 kHz and higher	From four–six cycles, depending on the type of power system distribution equipment	From 2–60 s if correction is automatic; from 15 min to 4 hr if manual

(1) The approximate limits beyond which the disturbance is considered to be harmful to the load equipment.

**Table 11.2** Causes of Power-Related Computer Failures, Northern Virginia, 1976 (*After* [1].)

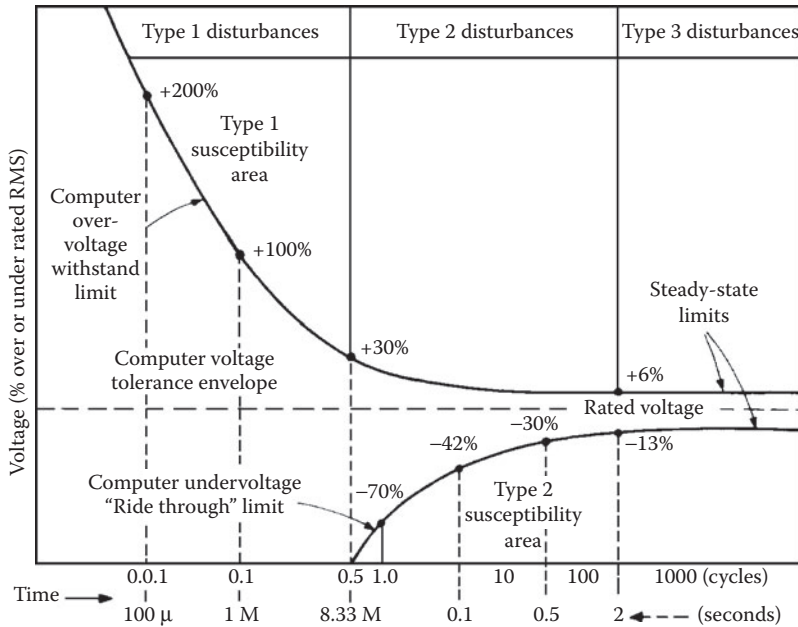
Recorded Cause	Disturbance		Number of Computer Failures
	Undervoltage	Outage	
Wind and lightning	37	14	51
Utility equipment failure	8	0	8
Construction or traffic accident	8	2	10
Animals	5	1	6
Tree limbs	1	1	2
Unknown	21	2	23
Totals	80	20	100

**Table 11.3** Effects of Power System Configuration on Incidence of Computer Failures (*After* [1].)

Configuration	Number of Disturbances		Recorded Failures
	Undervoltage	Outage	
Overhead radial	12	6	18
Overhead spot network	22	1	23
Combined overhead, weighted (1)	16	4	20
Underground radial	6	4	10
Underground network	5	0	5
Combined underground, weighted (1)	5	2	7

(1) The combined averages weighted based on the length of time monitored (30 to 53 months).





**Figure 11.1** The recommended voltage tolerance envelope for computer equipment. This chart is based on pioneering work done by the Naval Facilities Engineering Command. The study identified how the magnitude *and* duration of a transient pulse must be considered in determining the damaging potential of a spike. The design goals illustrated in the chart are recommendations to computer manufacturers for implementation in new equipment. (After [1].)

### 11.3 Assessing the Lightning Hazard

As identified by Key in his Naval Facilities study, the extent of lightning activity in an area significantly affects the probability of equipment failure caused by transient activity. The threat of a lightning flash to a facility is determined, in large part, by the type of installation and its geographic location. The type and character of the lightning flash are also important factors.

The *Keraunic number* of a geographic location describes the likelihood of lightning activity in that area. Figure 11.2 shows the *Isokeraunic map* of the U.S., which estimates the number of lightning days per year across the country. On average, 30 storm days occur per year across the continental U.S. This number does not fully describe the lightning threat because many individual lightning flashes occur during a single storm.

The structure of a facility has a significant effect on the exposure of equipment to potential lightning damage. Higher structures tend to collect and even trigger localized lightning flashes. Because storm clouds tend to travel at specific heights above the earth, conductive structures in mountainous areas more readily attract lightning activity. The *plant exposure factor* is a function of the size of the facility and the Isokeraunic rating of the area. The larger the physical size of an installation, the more likely it is to be hit by lightning during a storm. The longer a transmission line (ac or RF), the more lightning flashes it is likely to receive.

The relative frequency of power problems is seasonal in nature. As shown in Figure 11.3, most problems are noted during June, July, and August. These high problem rates can be traced primarily to increased thunderstorm activity.

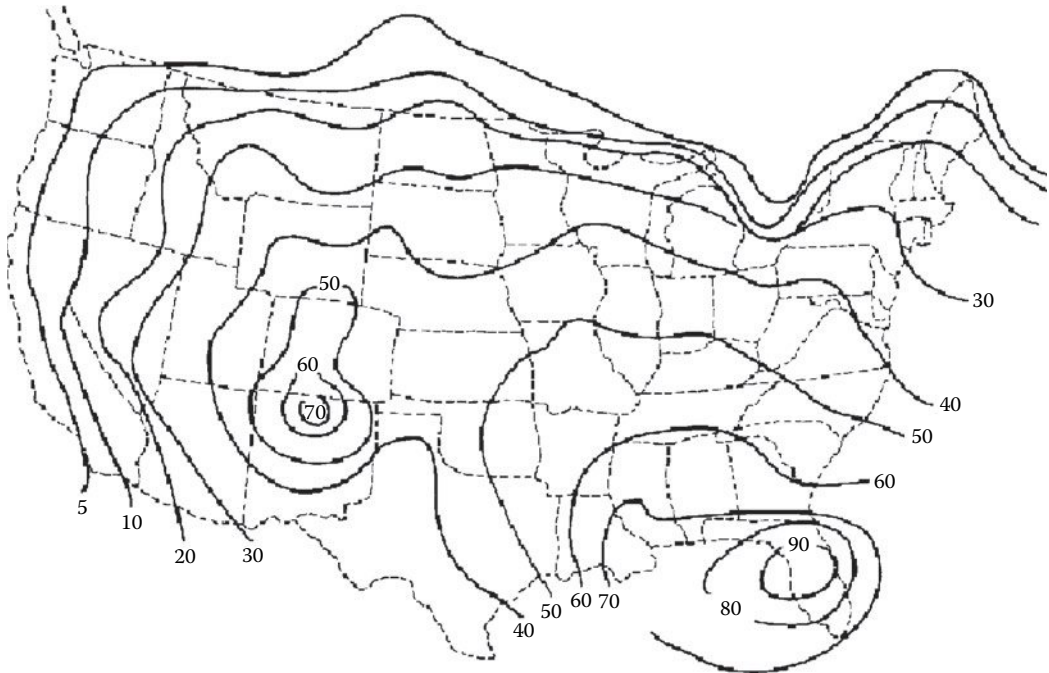


Figure 11.2 The Isokeraunic map of the U.S., showing the approximate number of lightning days per year.

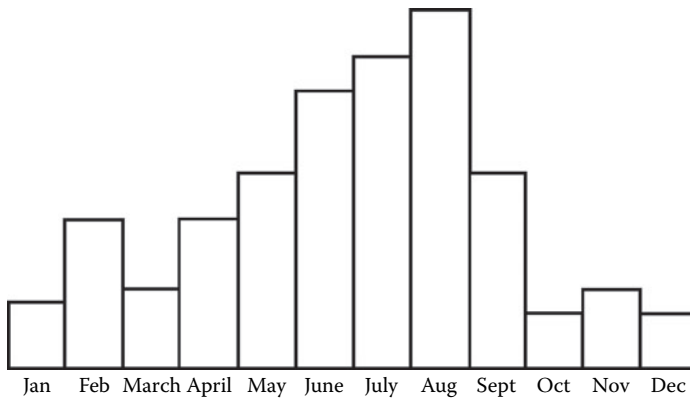


Figure 11.3 The relative frequency of power problems in the U.S., classified by month.

### 11.4 FIPS Publication 94

In 1983, the U.S. Department of Commerce published a guideline summarizing the fundamentals of powering, grounding, and protecting sensitive electronic devices [2]. The document, known as Federal Information Processing Standards (FIPS) Publication Number 94, was first reviewed by governmental agencies and then was sent to the Computer Business Equipment Manufacturers Association (CBEMA) for review. When the CBEMA group put its stamp of approval on the document, the data processing industry finally had an overarching guideline for power quality.

FIPS Pub. 94 was written to cover *automatic data processing* (ADP) equipment, which at that time constituted the principal equipment that was experiencing difficulty running on normal utility-supplied power. Since then, IEEE standard P1100 was issued, which applies to all sensitive electronic equipment. FIPS Pub. 94 is a guideline intended to provide a cost/benefit course of action. As a result, it can be relied

upon to give the best solution to typical problems that will be encountered, for the least amount of money.

In addition to approving the FIPS Pub. 94 document, the CBEMA group provided a curve that had been used as a guideline for their members in designing power supplies for modern electronic equipment. The CBEMA curve from the FIPS document is shown in Figure 11.4. Note the similarity to the Key tolerance envelope shown in Figure 11.1.

The curve is a susceptibility profile. In order to better explain its meaning, the curve has been simplified and redrawn in Figure 11.5. The vertical axis of the graph is the percentage of voltage that is applied to the power circuit, and the horizontal axis is the time factor involved (in  $\mu$ s to s). In the center of the chart is the acceptable operating area, and on the outside of that area is a danger area on top and bottom. The danger zone at the top is a function of the tolerance of equipment to excessive voltage levels. The danger zone on the bottom sets the tolerance of equipment to a loss or reduction in applied power. The CBEMA guideline states that if the voltage supply stays within the acceptable area given by the curve, the sensitive load equipment will operate as intended.

### 11.5 Protection Alternatives

A facility can be protected from ac line disturbances in two basic ways: the *systems* approach or the *discrete device* approach. Table 11.4 outlines the major alternatives available:

- Uninterruptible power system (UPS) and standby generator
- UPS stand-alone system
- Secondary ac spot network
- Secondary selective ac network
- Motor-generator (m-g) set

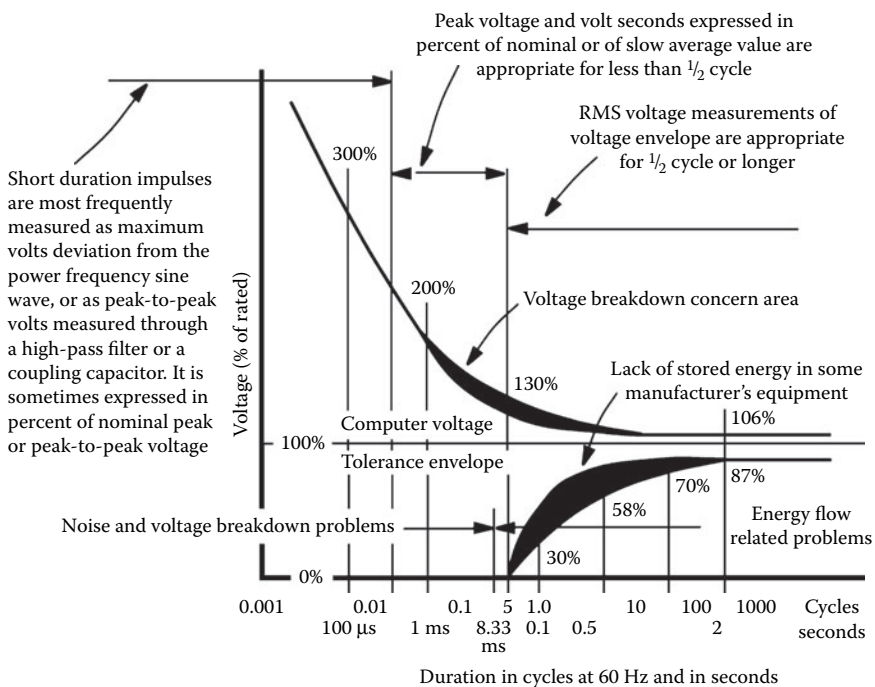
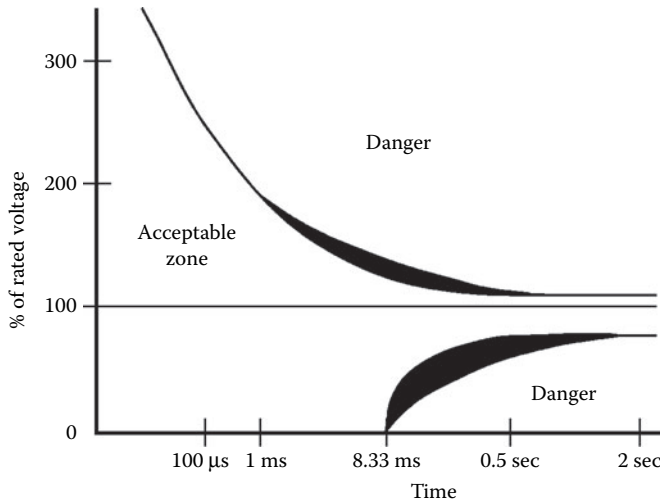


Figure 11.4 The CBEMA curve from FIPS Pub. 94. (From [2]. Used with permission.)



**Figure 11.5** A simplified version of the CBEMA curve. Voltage levels outside the *acceptable zone* result in potential system shutdown and hardware and software loss. (From [2]. Used with permission.)

**Table 11.4** Types of Systemwide Protection Equipment Available to Facility Managers and the AC Line Abnormalities That Each Approach Can Handle (After [1] and [2].)

System	Type 1	Type 2	Type 3
UPS system and standby generator	All source transients; no load transients	All	All
UPS system	All source transients; no load transients	All	All outages shorter than the battery supply discharge time
Secondary spot network (1)	None	None	Most, depending on the type of outage
Secondary selective network (2)	None	Most	Most, depending on the type of outage
Motor-generator set	All source transients; no load transients	Most	Only brown-out conditions
Shielded isolation transformer	Most source transients; no load transients	None	None
Suppressors, filters, lightning arrestors	Most transients	None	None
Solid-state line-voltage regulator/filter	Most source transients; no load transients	Some, depending on the response time of the system	Only brown-out conditions

(1) Dual power feeder network.  
 (2) Dual power feeder network using a static (solid-state) transfer switch.

- Shielded isolation transformer
- Suppressors, filters, and lightning arrestors
- Solid-state line-voltage regulator/filter

Table 11.5 lists the relative benefits of each protection method. Because each installation is unique, a thorough investigation of the facility needs should be conducted before purchasing any equipment. The systems approach offers the advantages of protection engineered to a particular application and

need, and (usually) high-level factory support during equipment design and installation. The systems approach also means higher costs for the end user.

### 11.5.1 Specifying System-Protection Hardware

Developing specifications for systemwide power-conditioning/backup hardware requires careful analysis of various factors before a particular technology or a specific vendor is selected. Key factors in this process relate to the load hardware and load application. The electrical power required by a sensitive load may vary widely, depending on the configuration of the system. The principle factors that apply to system specification include the following:

- Power requirements, including voltage, current, power factor, harmonic content, and transformer configuration
- Voltage-regulation requirements of the load
- Frequency stability required by the load, and the maximum permissible *slew rate* (the rate of change of frequency per second)
- Effects of unbalanced loading
- Overload and inrush current capacity
- Bypass capability
- Primary/standby path transfer time
- Maximum standby power reserve time
- System reliability and maintainability
- Operating efficiency

An accurate definition of *critical applications* will aid in the specification process for a given site. The potential for future expansion also must be considered in all plans.

Power requirements can be determined either by measuring the actual installed hardware or by checking the nameplate ratings. Most nameplate ratings include significant safety margins. Moreover, the load normally will include a *diversity factor*; all individual elements of the load will not necessarily be operating at the same time.

Every load has a limited tolerance to noise and harmonic distortion. Total harmonic distortion (THD) is a measure of the quality of the waveform applied to the load. It is calculated by taking the geometric sum of the harmonic voltages present in the waveform and expressing that value as a percentage of the fundamental voltage. Critical DP loads typically can withstand 5% THD, where no single harmonic exceeds 3%. The power-conditioning system must provide this high-quality output waveform to the load, regardless of the level of noise or distortion present at the ac input terminals.

If a power-conditioning/standby system does not operate with high reliability, the results often can be disastrous. In addition to threats to health and safety, there is a danger of lost revenue or inventory, and hardware damage. Reliability must be considered from three different viewpoints:

- Reliability of utility ac power in the area.
- Impact of line-voltage disturbances on DP loads.
- Ability of the protection system to maintain reliable operation when subjected to expected and unexpected external disturbances.

The environment in which the power-conditioning system operates will have a significant effect on reliability. Extremes of temperature, altitude, humidity, and vibration can be encountered in various applications. Extreme conditions can precipitate premature component failure and unexpected system shutdown. Most power-protection equipment is rated for operation from 0 to 40°C. During a commercial power failure, however, the ambient temperature of the equipment room can easily exceed either value, depending on the exterior temperature. Operating temperature derating typically is required for altitudes in excess of 1000 ft.

**Table 11.5** Relative Merits of Systemwide Protection Equipment (After [1] and [2]).

System	Strong Points	Weak Points	Technical Profile
UPS system and standby generator	Full protection from power outage failures and transient disturbances; ideal for critical DP and life-safety loads	Hardware is expensive and may require special construction; electrically and mechanically complex; noise may be a problem; high annual maintenance costs	Efficiency 80–90%; typical high impedance presented to the load may be a consideration; frequency stability good; harmonic distortion determined by UPS system design
UPS system	Completely eliminates transient disturbances; eliminates surge and sag conditions; provides power outage protection up to the limits of the battery supply; ideal for critical load applications	Hardware is expensive; depending on battery supply requirements, special construction may be required; noise may be a problem; periodic maintenance required	Efficiency 80–90%; typical high impedance presented to the load may be a consideration; frequency stability good; harmonic content determined by inverter type
Secondary spot network (1)	Simple; inexpensive when available in a given area; protects against local power interruptions; no maintenance required by user	Not available in all locations; provides no protection from areawide utility failures; provides no protection against transient disturbances or surge/sag conditions	Virtually no loss, 100% efficient; presents low impedance to the load; no effect on frequency or harmonic content
Secondary selective network (2)	Same as above; provides faster transfer from one utility line to the other	Same as above	Same as above
Motor-generator set	Electrically simple; reliable power source; provides up to 0.5 s power-fail ride-through in basic form; completely eliminates transient and surge/sag conditions	Mechanical system requires regular maintenance; noise may be a consideration; hardware is expensive; depending upon m-g set design, power-fail ride-through may be less than typically quoted by manufacturer	Efficiency 80–90%; typical high impedance presented to the load may be a consideration; frequency stability may be a consideration, especially during momentary power-fail conditions; low harmonic content
Shielded isolation transformer	Electrically simple; provides protection against most types of transients and noise; moderate hardware cost; no maintenance required	Provides no protection from brown-out or outage conditions	No significant loss, essentially 100% efficient; presents low impedance to the load; no effect on frequency stability; usually low harmonic content
Suppressors, filters, lightning arrestors	Components inexpensive; units can be staged to provide transient protection exactly where needed in a plant; no periodic maintenance required	No protection from Type 2 or 3 disturbances; transient protection only as good as the installation job	No loss, 100% efficient; some units subject to power-follow conditions; no effect on impedance presented to the load; no effect on frequency or harmonic content
Solid-state line-voltage regulator/filter	Moderate hardware cost; uses a combination of technologies to provide transient suppression and voltage regulation; no periodic maintenance required	No protection against power outage conditions; slow response time may be experienced with some designs	Efficiency 92–98%; most units present low impedance to the load; usually no effect on frequency; harmonic distortion content may be a consideration

(1) Dual power feeder network.  
(2) Dual power feeder network using a static (solid-state) transfer switch.

Table 11.6 lists key power-quality attributes that should be considered when assessing the need for power-conditioning hardware.

**Table 11.6** Power-Quality Attributes for Data Processing Hardware (After [2].)

Environmental Attribute	Typical Environment	Acceptable Limits for DP Systems	
		Normal	Critical
Line frequency	$\pm 0.1$ to $\pm 3\%$	$\pm 1\%$	$\pm 0.3\%$
Rate of frequency change	0.5 to 20 Hz/s	1.5 Hz/s	0.3 Hz/s
Over- and under-voltage	$\pm 5$ to $+6$ , $-13.3\%$	$+5$ to $-10\%$	$\pm 3\%$
Phase imbalance	2 to 10%	5% max	3% max
Tolerance to low power factor	0.85 to 0.6 lagging	0.8 lagging	less than 0.6 lagging, or 0.9 leading
Tolerance to high steady-state peak current	1.3 to 1.6 peak, rms	1.0 to 2.5 peak, rms	Greater than 2.5 peak, rms
Harmonic voltages	0 to 20% total rms	10 to 20% total, 5 to 10% largest	5% max total, 3% largest
Voltage deviation from sine wave	5 to 50%	5 to 10%	3 to 5%
Voltage modulation	Negligible to 10%	3% max	1% max
Surge/sag conditions	$+10$ , $-15\%$	$+20$ , $-30\%$	$+5$ , $-5\%$
Transient impulses	2 to 3 times nominal peak value (0 to 130% Vs)	Varies; 1.0 to 1.5 kV typical	Varies; 200 to 500 V typical
RFI/EMI normal and common modes	10 V up to 20 kHz, less at high freq.	Varies widely; 3 V typical	Varies widely; 0.3 V typical
Ground currents	0 to 10 A plus impulse noise current	0.001 to 0.5 A or more	0.0035 A or less

## 11.6 References

1. Key, Lt. Thomas: "The Effects of Power Disturbances on Computer Operation," IEEE Industrial and Commercial Power Systems Conference, Cincinnati, OH, June 7, 1978.
2. Federal Information Processing Standards Publication No. 94, *Guideline on Electrical Power for ADP Installations*, U.S. Department of Commerce, National Bureau of Standards, Washington, DC, 1983.

## 11.7 Bibliography

- Lawrie, R., *Electrical Systems for Computer Installations*, McGraw-Hill, New York, 1988.
- Martzloff, F. D., "The Development of a Guide on Surge Voltages in Low-Voltage AC Power Circuits," 14th Electrical/Electronics Insulation Conference, IEEE, Boston, MA, October 1979.
- Pettinger, W., "The Procedure of Power Conditioning," *Microservice Management*, Intertec Publishing, Overland Park, KS, March 1990.
- Smeltzer, D., "Getting Organized about Power," *Microservice Management*, Intertec Publishing, Overland Park, KS, March 1990.



# 12

## Motor-Generator Set

---

### 12.1 Introduction

---

As the name implies, a motor-generator (m-g) set consists of a motor powered by the ac utility supply that is mechanically tied to a generator, which feeds the load. (See [Figure 12.1](#).) Transients on the utility line will have no effect on the load when this arrangement is used. Adding a flywheel to the motor-to-generator shaft will protect against brief power dips (up to 0.5 s on many models). [Figure 12.2](#) shows the construction of a typical m-g set. The attributes of an m-g include the following:

- An independently generated source of voltage can be regulated without interaction with line-voltage changes on the power source. Utility line changes of  $\pm 20\%$  commonly can be held to within  $\pm 1\%$  at the load.
- The rotational speed and inertial momentum of the rotating mass represents a substantial amount of stored rotational energy, preventing sudden changes in voltage output when the input is momentarily interrupted.
- The input and output windings are separated electrically, preventing transient disturbances from propagating from the utility company ac line to the load.
- Stable electrical characteristics for the load: (1) output voltage and frequency regulation, (2) ideal sine wave output, and (3) true  $120^\circ$  phase shift for three-phase models.
- Reduced problems relating to the power factor presented to the utility company power source.

The efficiency of a typical m-g ranges from 65 to 89%, depending on the size of the unit and the load. Motor-generator sets have been used widely to supply 415 Hz power to mainframe computers that require this frequency.

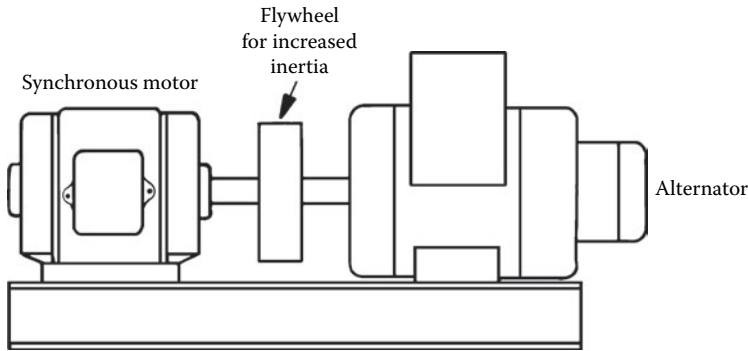
### 12.2 System Configuration

---

There are a number of types of motor-generator sets, each having its own characteristics, advantages, and disadvantages. A simplified schematic diagram of an m-g is shown in [Figure 12.3](#). The type of motor that drives the set is an important design element. Direct-current motor drives can be controlled in speed independently of the frequency of the ac power source from which the dc is derived. Use of a dc motor thereby gives the m-g set the capability to produce power at the desired output frequency, regardless of variations in input frequency. The requirement for rectifier conversion hardware, control equipment, and commutator maintenance are drawbacks to this approach that must be considered.

The simplest and least-expensive approach to rotary power conditioning involves the use of an induction motor as the mechanical source. Unfortunately, the rotor of an induction motor turns slightly slower than the rotating field produced by the power source. This results in the generator being unable to produce 60 Hz output power if the motor is operated at 60 Hz and the machines are directly coupled end-to-end at their shafts, or are belted in a 1:1 ratio. Furthermore, the shaft speed and output frequency of the generator decreases as the load on the generator is increased. This potential for varying output frequency may be acceptable where the m-g set is used solely as the input to a power supply in which the ac is rectified and converted to dc. However, certain loads cannot tolerate frequency changes greater than 1 Hz/s and frequency deviations of more than 0.5 Hz from the nominal 60 Hz value.





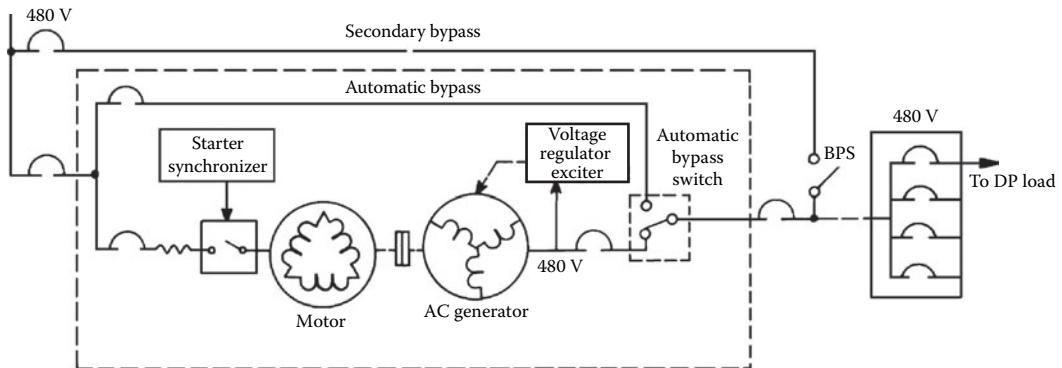
**Figure 12.1** Two-machine motor-generator set with an optional flywheel to increase inertia and carry-through capability.

Low-slip induction motor-driven generators are available that can produce 59.7 Hz at full load, assuming 60 Hz input. During power interruptions, the output frequency will drop further, depending upon the length of the interruption. The capability of the induction motor to restart after a momentary power interruption is valuable. Various systems of variable-speed belts have been tried successfully. Magnetically controlled slipping clutches have been found to be largely unsatisfactory. Other approaches to make the induction motor drive the load at constant speed have produced mixed results.

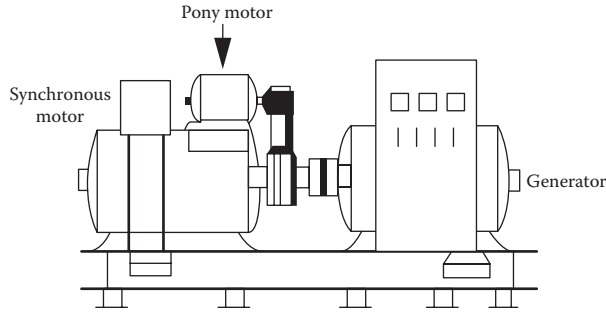


**Figure 12.2** Construction of a typical m-g set. (Courtesy of Computer Power Protection.)

Using a synchronous motor with direct coupling or a cogged 1:1 ratio belt drive guarantees that the output frequency will be equal to the motor input frequency. Although the synchronous motor is more expensive, it is more efficient and can be adjusted to provide a unity PF load to the ac source. The starting characteristics and the mechanical disturbance following a short line-voltage interruption depend, to a large extent, on motor design. Many synchronous motors that are not required to start under load have weak starting torque and may use a *pony motor* to aid in starting. This approach is shown in Figure 12.4.



**Figure 12.3** Simplified schematic diagram of an m-g set with automatic and secondary bypass capability. (After [1].)



**Figure 12.4** Use of a pony motor for an m-g set to aid in system starting and restarting. (After [1].)

Those motors designed to start with a load have starting pole face windings that provide starting torque comparable to that of an induction motor. Such motors can be brought into synchronism while under load with proper selection of the motor and automatic starter system. Typical utility company ac interruptions are a minimum of six cycles (0.1 s). Depending upon the design and size of the flywheel used, the ride-through period can be as much as 0.5 s or more. The generator will continue to produce output power for a longer duration, but the frequency and rate of frequency change will most likely fall outside of the acceptable range of most DP loads after 0.5 s.

If input power is interrupted and does not return before the output voltage and frequency begin to fall outside acceptable limits, the generator output controller can be programmed to disconnect the load. Before this event, a warning signal is sent to the DP control circuitry to warn of impending shutdown and to initiate an orderly interruption of active computer programs. This facilitates easy restart of the computer after the power interruption has passed.

It is important for users to accurately estimate the length of time that the m-g set will continue to deliver acceptable power without input to the motor from the utility company. This data facilitates accurate power-fail shutdown routines. It is also important to ensure that the m-g system can handle the return of power without operating overcurrent protection devices because of high inrush currents that may be required to accelerate and synchronize the motor with the line frequency. Protection against the latter problem requires proper programming of the synchronous motor controller to correctly disconnect and then reconnect the field current supply. It may be worthwhile to delay an impending shutdown for 100 ms or so. This would give the computer time to prepare for the event through an orderly interruption. It also would be useful if the computer were able to resume operation without shutdown, in case utility power returns within the ride-through period. Control signals from the m-g controller should be configured to identify these conditions and events to the DP system.

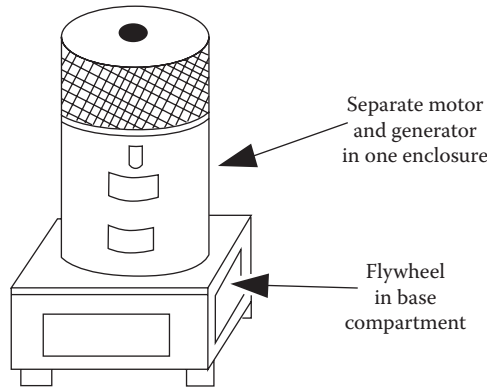
Generators typically used in m-g sets have substantially higher internal impedance than equivalent kVA-rated transformers. Because of this situation, m-g sets sometimes are supplied with an oversized generator that will be lightly loaded, coupled with a smaller motor that is adequate to drive the actual load. This approach reduces the initial cost of the system, decreases losses in the motor, and provides a lower operating impedance for the load.

Motor-generator sets can be configured for either horizontal installation, as shown previously, or for vertical installation, as illustrated in [Figure 12.5](#).

The most common utility supply voltage used to drive the input of an m-g set is 480 V. The generator output for systems rated at about 75 kVA or less is typically 208 Y/120 V. For larger DP systems, the most economical generator output is typically 480 V. A 480 to 208 Y/120 V three-phase isolating transformer usually is included to provide 208 Y/120 V power to the computer equipment.

### 12.2.1 Motor Design Considerations

Both synchronous and induction motors have been used successfully to drive m-g sets, and each has advantages and disadvantages. The major advantage of the synchronous motor is that while running



**Figure 12.5** Vertical m-g set with an enclosed flywheel. (After [1].)

normally, it is synchronized with the supply frequency. An 1800 rpm motor rotates at exactly 1800 rpm for a supply frequency of exactly 60 Hz. The generator output, therefore, will be exactly 60 Hz. Utility frequencies *average* 60 Hz; utilities vary the frequency slowly to maintain this average value under changing load conditions. Research has shown that utility operating frequencies typically vary from 58.7 to 60.7 Hz. Although frequency tolerances permitted by most computer manufacturers are usually given as  $\pm 0.5$  Hz on a nominal 60 Hz system, these utility variations are spread over a 24-hour period or longer and generally do not result in problems for the load.

The major disadvantage of a synchronous motor is that the device is difficult to start. A synchronous motor must be started and brought up to *pull-in* speed by an auxiliary winding on the armature, known as the *armortisseur* winding. The pull-in speed is the minimum speed (close to synchronous speed) at which the motor will pull into synchronization if excitation is applied to the field. The armortisseur winding is usually a squirrel-cage design, although it may be of the wound-rotor type in some cases. This winding allows the synchronous motor to start and come up to speed as an induction motor. When pull-in speed is achieved, automatic sensing equipment applies field excitation, and the motor locks in and runs as a synchronous machine. As discussed previously, some large synchronous motors are brought up to speed by an auxiliary pony motor.

The armortisseur winding can produce only limited torque, so synchronous motors usually are brought up to speed without a load. This requirement presents no problem for DP systems upon initial startup. However, in the event of a momentary power outage, problems can develop. When the utility ac fails, the synchronous motor must be disconnected from the input immediately, or it will act as a generator and feed power back into the line, thus rapidly depleting its stored (kinetic) rotational energy. During a power failure, the speed of the motor rapidly drops below the pull-in speed, and when the ac supply returns, the armortisseur winding must reaccelerate the motor under load until the field can be applied again. This requires a large winding and a sophisticated control system. When the speed of the m-g set is below synchronous operation, the generator output frequency may be too low for proper computer operation.

The induction motor has no startup problems, but it does have *slip*. To produce torque, the rotor must rotate at slightly lower speed than the stator field. For a nominal 1800 rpm motor, the actual speed will be about 1750 rpm, varying slightly with the load and the applied input voltage. This represents a slip of about 2.8%. The generator, if driven directly or on a common shaft, will have an output frequency of about 58.3 Hz. This is below the minimum permissible operating frequency for most computer hardware. Special precision-built low-slip induction motors are available with a slip of approximately 0.5% at a nominal motor voltage of 480 V. With 0.5% slip, speed at full load will be about 1791 rpm, and the directly driven or common-shaft generator will have an output frequency of 59.7 Hz. This frequency is within tolerance, but close to the minimum permissible frequency.

A belt-and-pulley system adjustable-speed drive is a common solution to this problem. By making the pulley on the motor slightly larger in diameter than the pulley on the generator (with the actual diameters adjustable) the generator can be driven at synchronous speed.

Voltage sags have no effect on the output frequency of a synchronous motor-driven m-g set until the voltage gets so low that the torque is reduced to a point at which the machine pulls out of synchronization. Resynchronization then becomes a problem. On an induction motor, when the voltage sags, slip increases and the machine slows down. The result is a drop in generator output frequency. The adjustable-speed drive between an induction motor and the generator solves the problem for separate machines. If severe voltage sags are anticipated at a site, the system can be set so that nominal input voltage from the utility company produces a frequency of 60.5 Hz, 0.5 Hz on the high side of nominal frequency. Figure 12.6 charts frequency vs. motor voltage for three operating conditions:

- Slip compensation set high (curve A)
- Slip compensation set for 60 Hz (curve B)
- No slip compensation (curve C)

Through proper adjustment of slip compensation, considerable input-voltage margins can be achieved.

### 12.2.1.1 Single-Shaft Systems

There are two basic m-g set machine mechanical designs used for DP applications: (1) separate motor-generator systems, and (2) single-shaft, single-housing units. Both designs can use either a synchronous or induction motor. In each case, there are advantages and disadvantages. The separate machine design (discussed previously) uses a motor driving a physically separate generator by means of a coupling shaft or pulley. In an effort to improve efficiency and reduce costs, manufacturers also have produced various types of single-shaft systems.

The basic concept of a single-shaft system is to combine the motor and generator elements into a single unit. A common stator eliminates a number of individual components, making the machine less expensive to produce and mechanically more efficient. The common-stator set substantially reduces mechanical energy losses associated with traditional m-g designs, and it improves system reliability, as well. In one design, the stator is constructed so that alternate slots are wound with input and output

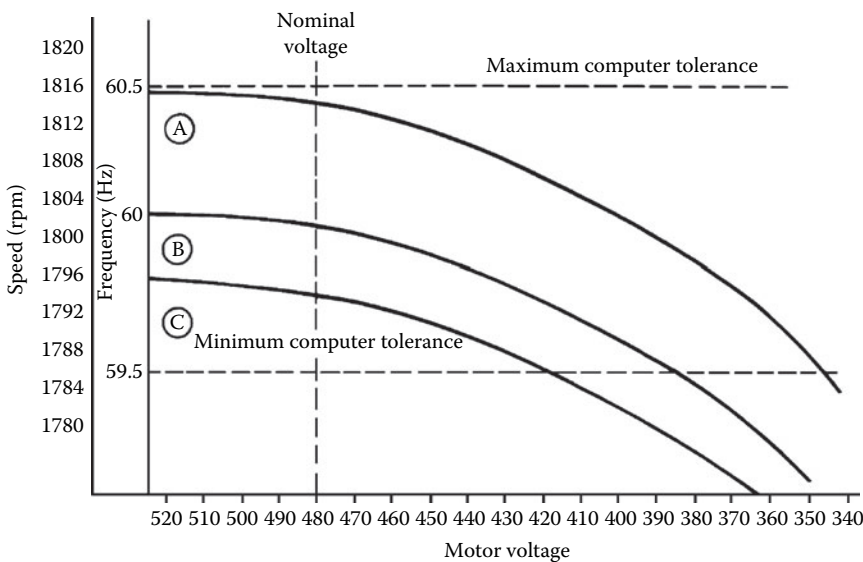


Figure 12.6 Generator output frequency vs. motor input voltage for an induction-motor-based m-g set.

windings. When it is fed with a three-phase supply, a rotating magnetic field is created, causing the dc-excited rotor to spin at a synchronous speed. By controlling the electrical characteristics of the rotor, control of the output at the secondary stator windings is accomplished.

Common-stator machines offer lower working impedance for the load than a comparable two-machine system. For example, a typical 400 kVA machine has approximately an 800 kVA frame size. The larger frame size yields a relatively low-impedance power source capable of clearing subcircuit fuses under fault conditions. The output of the unit typically can supply up to seven times the full-load current under fault conditions. Despite the increase in frame size, the set is smaller and lighter than comparable systems because of the reduced number of mechanical parts.

### 12.2.2 Flywheel Considerations

In an effort to achieve higher energy and power densities, m-g set designers have devoted considerable attention to the flywheel element itself. New composite materials and power electronics technologies have resulted in compact flywheel “batteries” capable of high linear velocity at the outside radius of the flywheel (*tip speed*) [2]. The rotational speed of the flywheel is important because the stored energy in a flywheel is proportional to the square of its rotational speed. Therefore, an obvious method for maximizing stored energy is to increase the speed of the flywheel. All practical designs, however, have a limiting speed, which is determined by the stresses developed within the wheel resulting from inertial loads. These loads are also proportional to the square of rotational speed. Flywheels built of composite materials weigh less and, hence, develop lower inertial loads at a given speed. In addition, composites are often stronger than conventional engineering metals, such as steel. This combination of high strength and low weight enables extremely high tip speeds, relative to conventional wheels.

For a given geometry, the limiting *energy density* (energy per unit mass) of a flywheel is proportional to the ratio of material strength to weight density, otherwise known as the *specific strength*. Table 12.1 illustrates the advantage that composite materials offer in this respect.

Recent advances in composite materials technology may allow nearly an order of magnitude advantage in the specific strength of composites when compared to even the best common engineering metals. The result of this continuous research in composites has been flywheels capable of operation at rotational speeds in excess of 100,000 rpm, with tip speeds in excess of 1000 m/s.

These high speeds bring with them new challenges. The ultrahigh rotational speeds that are required to store significant kinetic energy in these systems virtually rule out the use of conventional mechanical bearings. Instead, most systems run on magnetic bearings. This relatively recent innovation uses magnetic forces to levitate a rotor, eliminating the frictional losses inherent in rolling element and fluid film bearings. Unfortunately, aerodynamic drag losses force most high-speed flywheels to operate in a partial vacuum, which complicates the task of dissipating the heat generated by ohmic losses in the bearing electromagnets and rotor. In addition, active magnetic bearings are inherently unstable and require sophisticated control systems to maintain proper levitation.

The integrated generator of these systems is usually a rotating-field design, with the magnetic field supplied by rare-earth permanent magnets. Because the specific strength of these magnets is typically just fractions of that of the composite flywheel, they must spin at much lower tip speeds; in other words, they must be placed very near the hub of the flywheel. This compromises the power density of the generator.

**Table 12.1** Specific Strength of Selected Materials (After [3].)

Material	Specific Strength (in. <sup>3</sup> )
Graphite/epoxy	3,509,000
Boron/epoxy	2,740,000
Titanium and alloys	1,043,000
Wrought stainless steel	982,000
Wrought high-strength steel	931,000
7000 series aluminum alloys	892,000

An alternative is to mount them closer to the outer radius of the wheel, but contain their inertial loads with the composite wheel itself. Obviously, this forces the designer to either derate the machine speed or operate closer to the stress limits of the system.

### 12.2.3 Maintenance Considerations

Because m-g sets require some maintenance that necessitates shutdown, most systems provide bypass capability so the maintenance work can be performed without having to take the computer out of service. If the automatic bypass contactor, solid-state switch, and control hardware are in the same cabinet as other devices that also need to be de-energized for maintenance, a secondary bypass is recommended. After the automatic bypass path has been established, transfer switching to the secondary bypass can be enabled, taking the m-g set and its automatic bypass system out of the circuit completely. Some automatic bypass control arrangements are designed to transfer the load of the generator to the bypass route with minimum disturbance. This requires the generator output to be synchronized with the bypass power before closing the switch and opening the generator output breaker. However, with the load taken off the generator, bypass power no longer will be synchronized with it. Consequently, retransfer of the load back to the generator may occur with some disturbance. Adjustment for minimum disturbance in either direction requires a compromise in phase settings, or a means to shift the phase before and after the transfer.

The use of rotating field exciters has eliminated the need for slip rings in most m-g designs. Brush inspection and replacement, therefore, are no longer needed. However, as with any rotating machinery, bearings must be inspected and periodically replaced.

### 12.2.4 Motor-Generator UPS

Critical DP applications that cannot tolerate even brief ac power interruptions can use the m-g set as the basis for an uninterruptible source of power through the addition of a battery-backed dc motor to the line-driven ac motor shaft. This concept is illustrated in Figure 12.7. The ac motor normally supplies power to drive the system from the utility company line. The shafts of the three devices all are interconnected, as shown in the figure. When ac power is present, the dc motor serves as a generator to charge the

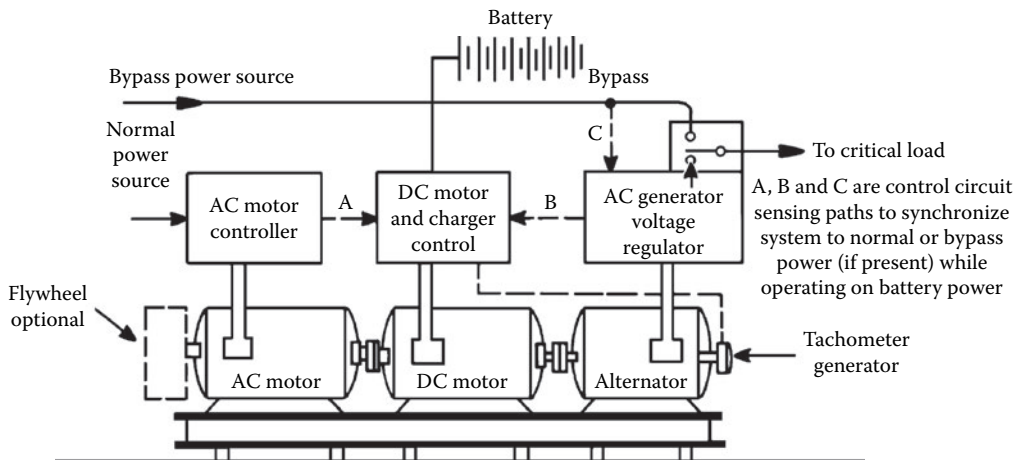


Figure 12.7 Uninterruptible m-g set with ac and dc motor drives. (After [1].)

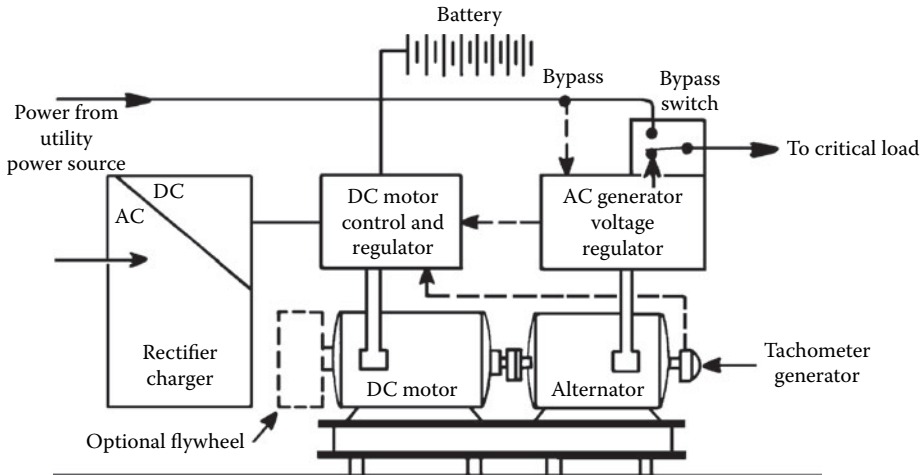


Figure 12.8 Uninterruptible m-g set using a single dc drive motor. (After [1].)

battery bank. When line voltage is interrupted, the dc motor is powered by the batteries. Figure 12.8 shows a modified version of this basic m-g UPS using only a dc motor as the mechanical power source. This configuration eliminates the inefficiency involved in having two motors in the system. Power from the utility source is rectified to provide energy for the dc motor, plus power for charging the batteries. A complex control system to switch the ac motor off and the dc motor on in the event of a utility power failure is not needed in this design.

The m-g UPS also can be built around a synchronous ac motor, as illustrated in Figure 12.9. Utility ac energy is rectified and used to drive an inverter, which provides a regulated frequency source to power the synchronous motor. The output from the dc-to-ac inverter need not be a well-formed sine wave, or a well-regulated source. The output from the generator will provide a well-regulated sine wave for the load. The m-g set also can be operated in a bypass mode that eliminates the rectifier, batteries, and inverter from the current path, operating the synchronous motor directly from the ac line.

An m-g UPS set using a common-stator machine is illustrated in Figure 12.10. A feedback control circuit adjusts the firing angle of the inverter to compensate for changes in input power. This concept is taken a step further in the system shown in Figure 12.11. A solid-state inverter bypass switch is added to improve efficiency. During normal operation, the bypass route is enabled, eliminating losses across the

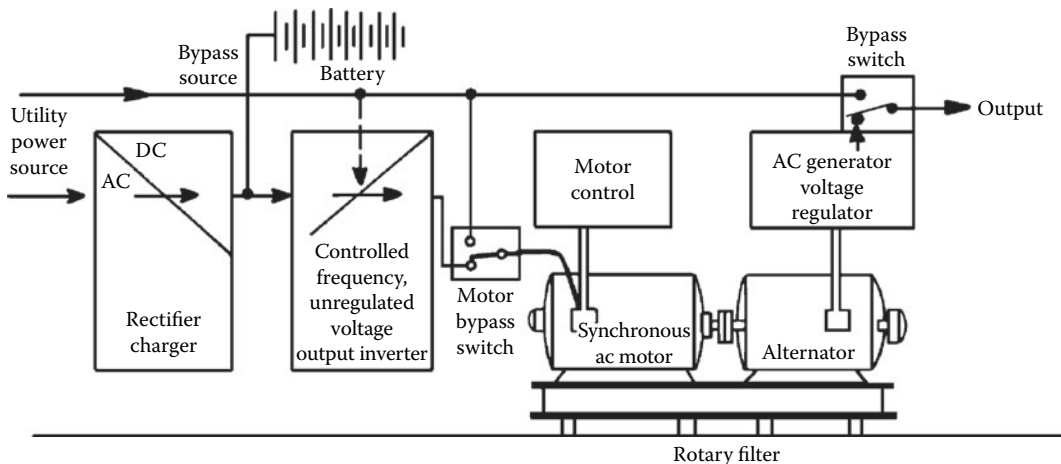
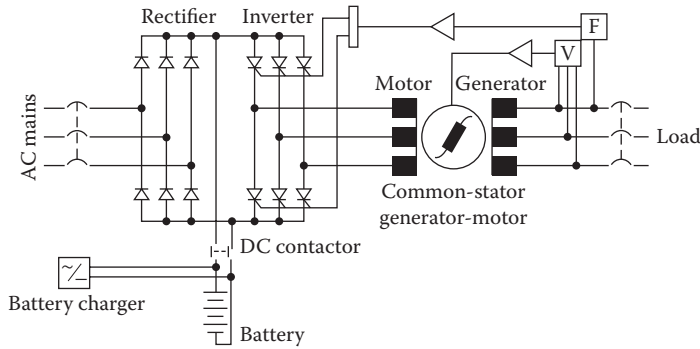
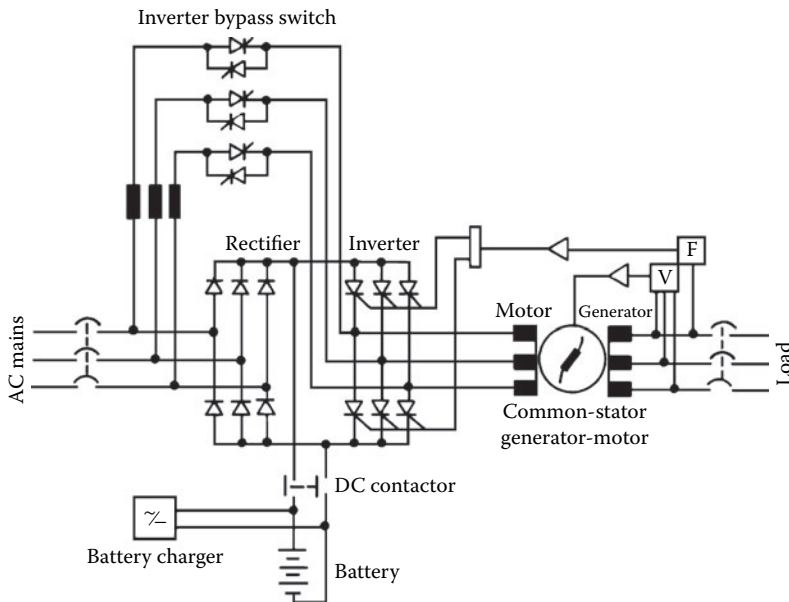


Figure 12.9 Uninterruptible m-g set using a synchronous ac motor. (After [1].)





**Figure 12.10** Common-stator UPS m-g set. The firing angle of the SCR inverters is determined by a feedback voltage from the generator output.



**Figure 12.11** Common-stator UPS m-g set with a solid-state inverter bypass switch.

rectifier diodes. When the control circuitry senses a drop in utility voltage, the inverter is switched on, and the bypass switch is deactivated. A simplified installation diagram of the inverter/bypass system is shown in Figure 12.12. Magnetic circuit breakers and chokes are included as shown. An isolation transformer is inserted between the utility input and the rectifier bank. The static inverter is an inherently simple design; commutation is achieved via the windings. Six thyristors are used. Under normal operating conditions, 95% of the ac power passes through the static switch; 5% passes through the inverter. This arrangement affords maximum efficiency, while keeping the battery bank charged and the rectifiers and inverter thyristors preheated. Preheating extends the life of the components by reducing the extent of thermal cycling that occurs when the load suddenly switches to the battery backup supply. The static switch allows for fast disconnect of the input ac when the utility power fails.

### 12.2.5 Kinetic Battery Storage System

As outlined previously, one of the parameters that limits the ride-through period of an m-g set is the speed decay of the flywheel/generator combination. As the flywheel slows down, the output frequency



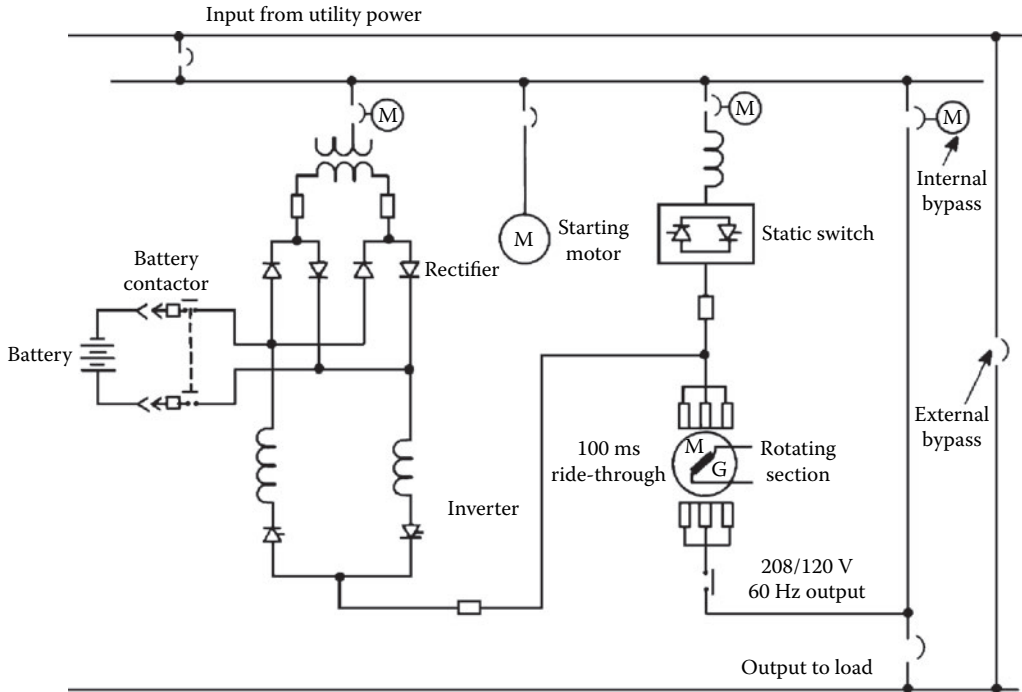


Figure 12.12 Power flow diagram of a full-featured UPS m-g set.

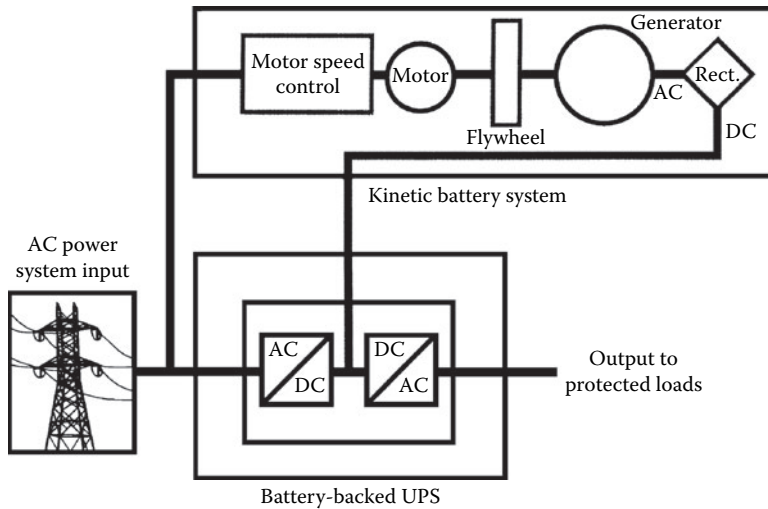


Figure 12.13 Functional block diagram of a kinetic battery m-g system for powering a UPS. (After [4].)

drops. This limits the useful ride-through period to 0.5 s or so. Figure 12.13 shows an ingenious modification of the classic power conditioning template that extends the potential ride-through considerably. As shown in the figure, an m-g set is used in a UPS-based system as an element of the dc supply grid. The major components of the system include:

- Steel flywheel for energy storage
- Small drive motor, sized at 15 to 20% of the rated system output, to start the flywheel and maintain its normal operating speed
- Variable speed drive (VSD) to slowly ramp the flywheel up to speed and maintain it at the desired rpm
- Generator to convert the kinetic energy stored in the flywheel into electrical energy
- Diode bridge rectifier to convert the ac generator output to dc for use by the UPS bus, which continues to draw usable energy essentially independent of flywheel rpm

Because the ac output of the generator is converted to dc, frequency is no longer a limiting factor, which allows the dc voltage output to be maintained over a much greater range of the flywheel's rpm envelope.

In operation, the small drive motor spins the flywheel while the variable speed drive maintains the proper motor speed [4]. Because the amount of stored kinetic energy increases by the square of the flywheel rpm, it is possible to greatly increase stored energy, and thus ride-through, by widening the flywheel's usable energy output range. These factors permit typical ride-through times from 10 s to several minutes, depending on loading and other operating conditions. The benefits of this approach include the reduced cycling of battery supplies and engine-generator systems.

## 12.3 References

---

1. Federal Information Processing Standards Publication No. 94, *Guideline on Electrical Power for ADP Installations*, U.S. Department of Commerce, National Bureau of Standards, Washington, DC, 1983.
2. Plater, B. B., and J. A. Andrews, "Advances in Flywheel Energy Storage Systems," *Power Quality '97*, Intertec International, Ventura, CA, pp. 460–469, 1997.
3. "Materials Selector, *Materials Engineering*, Penton Publishing, 1987.
4. Weaver, E. J., "Dynamic Energy Storage System," *Power Quality Solutions/Alternative Energy*, Intertec International, Ventura, CA, pp. 373–380, 1996.

## 12.4 Bibliography

---

- "How to Correct Power Line Disturbances," Dranetz Technologies, Edison, NJ, 1985.
- Lawrie, R., *Electrical Systems for Computer Installations*, McGraw-Hill, New York, 1988.
- Pettinger, W., "The Procedure of Power Conditioning," *Microservice Management*, Intertec Publishing, Overland Park, KS, March 1990.
- Smeltzer, D., "Getting Organized About Power," *Microservice Management*, Intertec Publishing, Overland Park, KS, March 1990.

# 13

## Uninterruptible Power Systems

---

### 13.1 Introduction

---

Uninterruptible power systems have become a virtual necessity for powering large or small computer systems where the application serves a critical need. Computers and data communications systems are no more reliable than the power from which they operate. The difference between UPS and *emergency standby power* is that the UPS is always in operation. It reverts to an alternative power source, such as the utility company, only if the UPS fails or needs to be deactivated for maintenance. Even then, the transfer of power occurs so quickly (within milliseconds) that it does not interrupt proper operation of the load.

Emergency standby power is normally off and does not start (manually or automatically) until the utility ac feed fails. A diesel generator can be started within 10 to 30 s if the system has been maintained properly. Such an interruption, however, is far too long for DP hardware. Most DP systems cannot ride through more than 8 to 22 ms of power interruption. Systems that can successfully ride through short-duration power breaks, as far as energy continuity is concerned, still may enter a fault condition because of electrical noise created by the disturbance.

UPS hardware is available in a number of different configurations. All systems, however, are variations of two basic designs:

- *Forward-transfer mode*: The load normally is powered by the utility power line, and the inverter is idle. If a commercial power failure occurs, the inverter is started and the load is switched. This configuration is illustrated in [Figure 13.1](#). The primary drawback of this approach is the lack of load protection from power-line disturbances during normal (utility-powered) operation.
- *Reverse-transfer mode*: The load normally is powered by the inverter. In the event of an inverter failure, the load is switched directly to the utility line. This configuration is illustrated in [Figure 13.2](#). The reverse-transfer mode is, by far, the most popular type of UPS system in use for large-scale systems.

The type of load-transfer switch used in the UPS system is another critical design parameter. The continuity of ac power service to the load is determined by the type of switching circuit used. An electromechanical transfer switch, shown in [Figure 13.3](#), is limited to switch times of 20 to 50 ms. This time delay can cause sensitive load equipment to malfunction and perhaps shut down. A control circuit actuates the relay when the sensed output voltage falls below a preset value, such as 94% of nominal. A static transfer switch, shown in [Figure 13.4](#), can sense a failure and switch the load in about 4 ms. Most loads will ride through this short delay without any malfunction. To accomplish a smooth transition, the inverter output must be synchronized with the power line.

### 13.2 UPS Configuration

---

The basic uninterruptible power system is built around a battery-driven inverter, with the batteries recharged by the utility ac line. As shown in [Figure 13.5](#), ac from the utility feed is rectified and applied to recharge or *float* a bank of batteries. This dc power drives a single- or multiphase closed-loop inverter, which regulates output voltage and frequency. The output of the inverter is generally a sine wave or pseudo sine wave (a stepped square wave). If the utility voltage drops or disappears, current is drawn from the batteries. When ac power is restored, the batteries are recharged. Many UPS installations incorporate a standby diesel

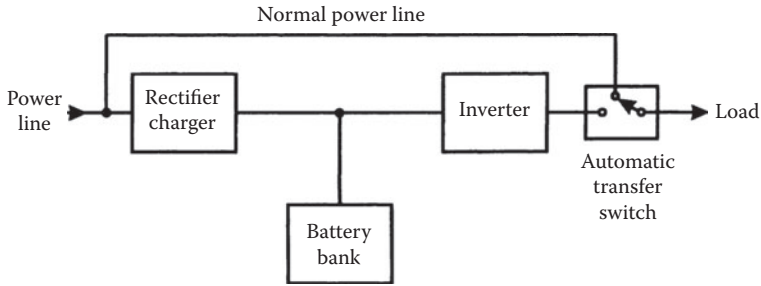


Figure 13.1 Forward-transfer UPS system.

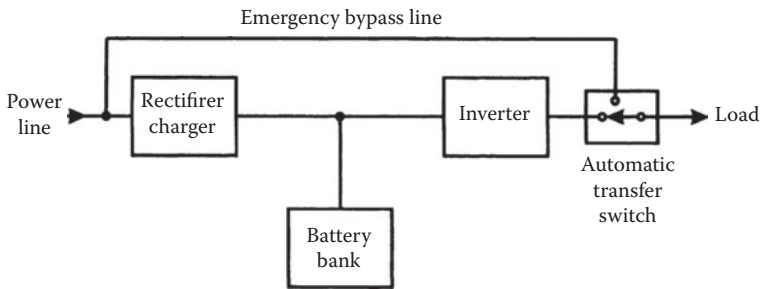


Figure 13.2 Reverse-transfer UPS system.

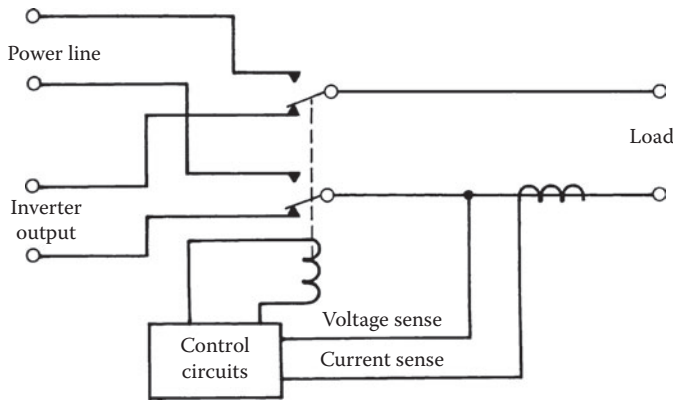


Figure 13.3 Electromechanical load-transfer switch.

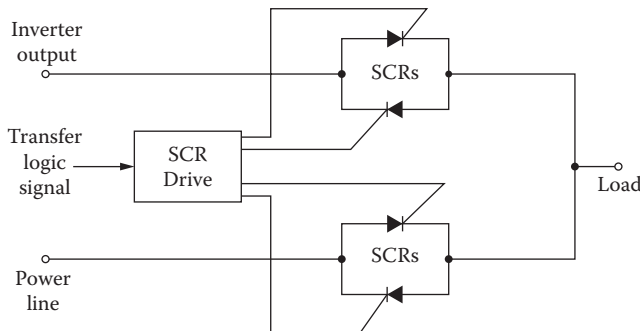
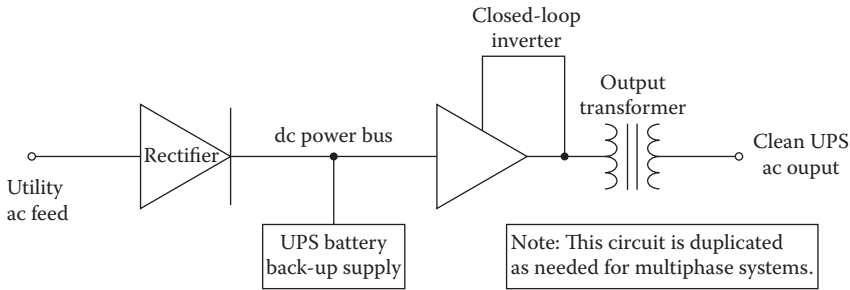


Figure 13.4 Static load-transfer switch.



**Figure 13.5** Block diagram of an uninterruptible power system using ac rectification to float the battery supply. A closed-loop inverter draws on this supply and delivers clean ac power to the protected load.

generator that starts as soon as the utility company feed is interrupted. With this arrangement, the batteries are called upon to supply operating current for only 30 s or so, until the generator gets up to speed. A UPS system intended to power a computer center is illustrated in Figure 13.6.

### 13.2.1 Power-Conversion Methods

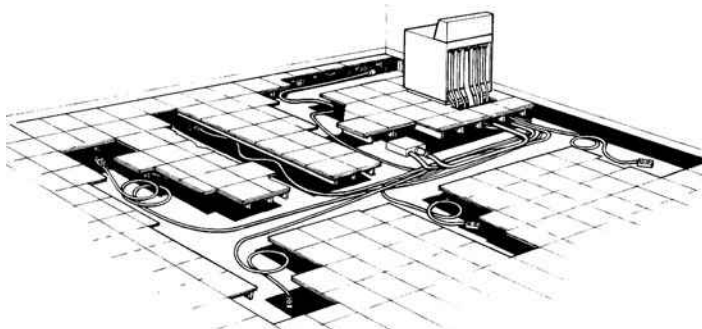
Solid-state UPS systems that do not employ rotating machinery utilize one of several basic concepts. The design of an inverter is determined primarily by the operating power level. The most common circuit configurations include:

- Ferroresonant inverter
- Delta magnetic inverter
- Inverter-fed  $L/C$  tank
- Quasi-square wave inverter
- Step wave inverter
- Pulse-width modulation (PWM) inverter
- Phase modulation inverter

In the following sections an overview of common inverter technologies is given.

#### 13.2.1.1 Ferroresonant Inverter

Illustrated in Figure 13.7, the ferroresonant inverter is popular for low- to medium-power applications. A ferroresonant transformer can be driven with a distorted, unregulated input voltage and deliver a regulated, sinusoidal output when filtered properly. The ferroresonant transformer core is designed so that the secondary section is magnetically saturated at the desired output voltage. As a result, the output level remains relatively constant over a wide range of input voltages and loads. Capacitors, connected across



**Figure 13.6** Installation details for a computer-room UPS power conditioner.

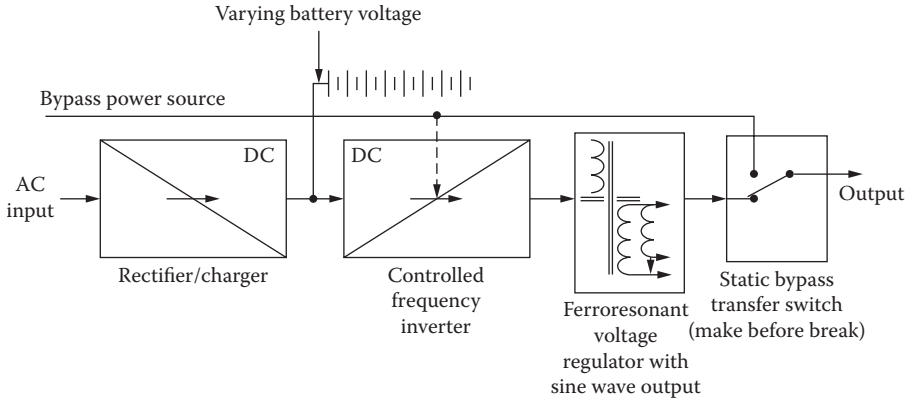


Figure 13.7 Simplified diagram of a static UPS system based on a ferroresonant transformer. (After [1]).

the secondary, help drive the core into saturation and, in conjunction with inductive coupling, provide harmonic filtering. Regulated, sinusoidal three-phase output voltages are derived from two inverters operating into ferroresonant transformers in a *Scott-T* configuration. The basic ferroresonant inverter circuit, shown in Figure 13.8, consists of an oscillator that controls SCR switches, which feed a ferroresonant transformer and harmonic filter. The saturated operating mode produces a regulated output voltage and inherent current limiting. Efficiency varies from 50 to 83%, depending on the load. Response time of the ferroresonant inverter is about 20 ms.

Although ferroresonant inverters are rugged, simple, and reliable, they do have disadvantages. First, such systems tend to be larger and heavier than electronically controlled inverters. Second, there is a phase shift between the inverter square wave and the output sine wave. This phase shift varies with load magnitude and power factor. When an unbalanced load is applied to a three-phase ferroresonant inverter, the output phases can shift from their normal 120° relationships. This results in a change in line-to-line voltages, even if individual line-to-neutral voltages are regulated perfectly. This voltage imbalance cannot be tolerated by some loads.

### 13.2.1.2 Delta Magnetic Inverter

Although most multiphase inverters are single-phase systems adapted to three-phase operation, the delta magnetic inverter is inherently a three-phase system. A simplified circuit diagram of a delta magnetic inverter is shown in Figure 13.9. Inverter modules A1, B1, and C1 produce square wave outputs that are

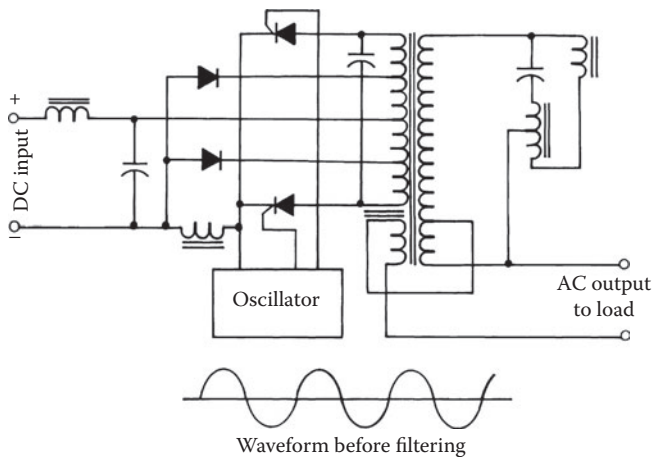
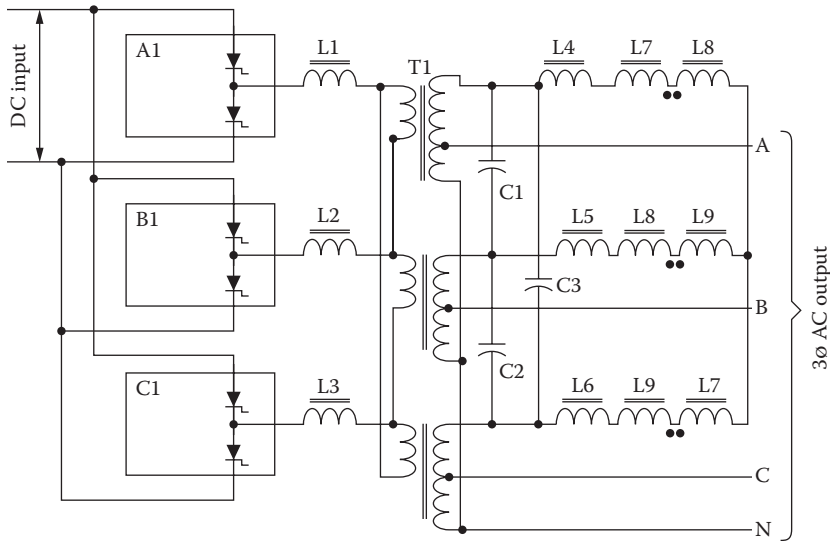


Figure 13.8 Simplified schematic diagram of a ferroresonant inverter. (After [1].)



**Figure 13.9** Simplified schematic diagram of the delta magnetic regulation system.

phase-shifted relative to each other by  $120^\circ$ . The waveforms are coupled to the primaries of transformer T1 through linear inductors. T1 is a conventional three-phase isolation transformer. The primaries of the device are connected in a delta configuration, reducing the third harmonic and all other harmonics that are odd-order multiples of the third. The secondaries of T1 are connected in a wye configuration to provide a four-wire three-phase output. Inductors L4 to L9 form a network connected in a delta configuration to high-voltage taps on the secondary windings of T1. Inductors L4 to L6 are single-winding saturating reactors, and L7 to L9 are double-winding saturating reactors. Current drawn by this saturating reactor network is nearly sinusoidal and varies in magnitude, in a nonlinear manner, with voltage variations. For example, if an increase in load tended to pull the inverter output voltages down, the reduced voltage applied to the reactor network would result in a relatively large decrease in current drawn by the network. This, in turn, would decrease the voltage drop across inductors L1 to L3 to keep the inverter output voltage at the proper level. The delta magnetic regulation technique is essentially a three-phase shunt regulator. Capacitors C1–C3 help drive the reactor network into saturation, as well as provide harmonic filtering in conjunction with the primary inductors.

### 13.2.1.3 Inverter-Fed L/C Tank

An inductor/capacitor tank is driven by a dc-to-ac inverter, as illustrated in [Figure 13.10](#). The tank circuit acts to reconstruct the sine wave at the output of the system. Regulation is accomplished by varying the capacitance or the inductance to control partial resonance or power factor. Some systems of this type use a saturable reactor in which electronic voltage-regulator circuits control the dc current in the reactor. Other systems, shown in [Figure 13.11](#), use a dc-to-variable-dc inverter/converter to control the UPS output through adjustment of the boost voltage. This feature permits compensation for changes in battery level.

### 13.2.1.4 Quasi-Square Wave Inverter

Shown in [Figure 13.12](#), the quasi-square wave inverter produces a variable-duty waveshape that must be filtered by tuned series and parallel inductive-capacitive networks to reduce harmonics and form a sinusoidal output. Because of the filter networks present in this design, the inverter responds slowly to load changes; response time in the range of 150 to 200 ms is common. Efficiency is about 80%. This type of inverter requires voltage-regulating and current-limiting networks, which increase circuit complexity and make it relatively expensive.

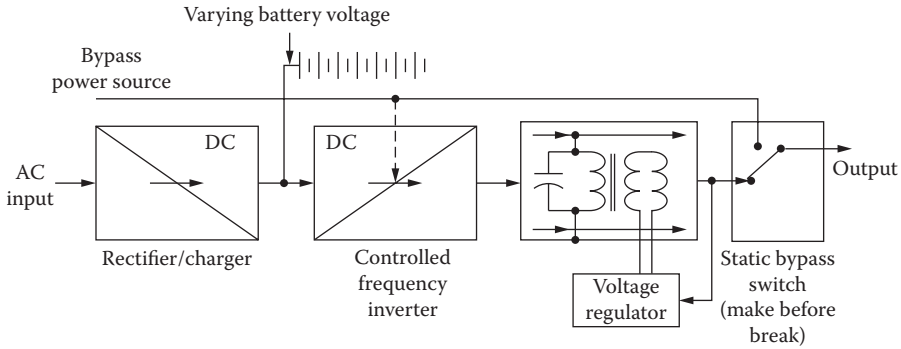


Figure 13.10 Static UPS system using saturable reactor voltage control. (After [1].)

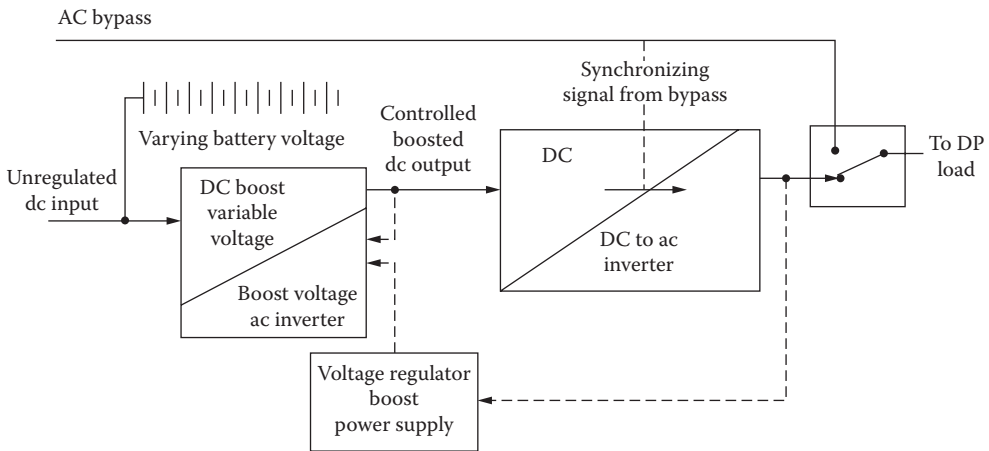


Figure 13.11 Static UPS system with dc boost voltage control. (After [1].)

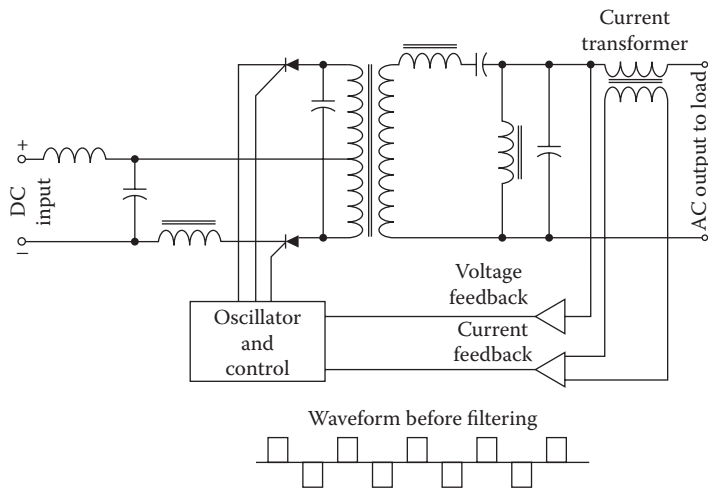


Figure 13.12 Simplified schematic diagram of a quasi-square wave inverter.



### 13.2.1.5 Step Wave Inverter

A multistep inverter drives a combining transformer, which feeds the load. The general concept is illustrated in Figure 13.13. The purity of the output sine wave is a function of the number of discrete steps produced by the inverter. Voltage regulation is achieved by a *boost* dc-to-dc power supply in series with the battery. Figure 13.14 and Figure 13.15 show two different implementations of single-phase units. Each system uses a number of individual inverter circuits, typically three or multiples of three. The inverters are controlled by a master oscillator; their outputs are added in a manner that reduces harmonics, producing a near-sinusoidal output. These types of systems require either a separate voltage regulator on the dc bus or a phase shifter. Response time is about 20 ms. Little waveform filtering is required, and efficiency can be as high as 85%. The step wave inverter, however, is complex and expensive. It usually is found only in large three-phase UPS systems.

### 13.2.1.6 Pulse-Width Modulation Inverter

Illustrated in Figure 13.16, the pulse-width modulation circuit incorporates two inverters that regulate the output voltage by varying the pulse width. The output closely resembles a sine wave. Reduced filtering requirements result in good voltage-regulation characteristics. Response times close to 100 ms are typical. The extra inverter and feedback networks make the PWM inverter complex and expensive. Such systems usually are found at power levels greater than 50 kVA.

### 13.2.1.7 Phase Modulation Inverter

Illustrated in Figure 13.17, this system uses dc-to-ac conversion through phase modulation of two square wave high-frequency signals to create an output waveform. The waveform then is filtered to remove the carrier signal and feed the load.

## 13.2.2 Redundant Operation

UPS systems can be configured as either a single, large power-conditioning/backup unit, or as several smaller systems arranged in a *parallel redundant* or *isolated redundant* mode. In the parallel redundant mode, the UPS outputs are connected together and share the total load. (See Figure 13.18.) The power-output ratings of the individual UPS systems are selected to provide for operation of the entire load with any one UPS unit out of commission. In the event of expansion of the DP facility, additional UPS units can be added to carry the load. The parallel system provides the ability to cope with the failure of any single unit.

An isolated redundant system, illustrated in Figure 13.19, divides the load among several UPS units. If one of the active systems fails, a static bypass switch will connect the affected load to a standby UPS system dedicated to that purpose. The isolated redundant system does not permit the unused capacity of one UPS unit to be utilized on a DP system that is loading another UPS to full capacity. The benefit of the isolated configuration is its immunity to systemwide failures.

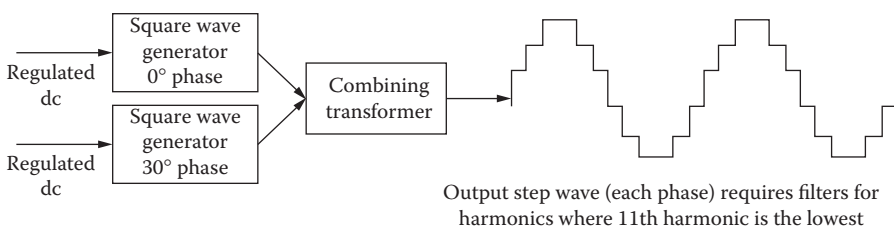


Figure 13.13 Static UPS system using a stepped wave output. (After [1].)

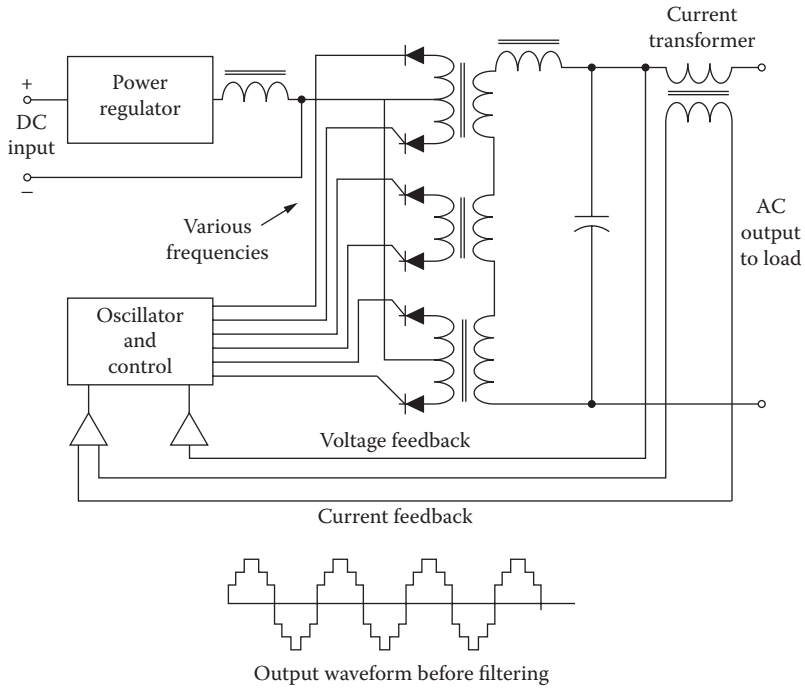


Figure 13.14 Step wave inverter schematic diagram.

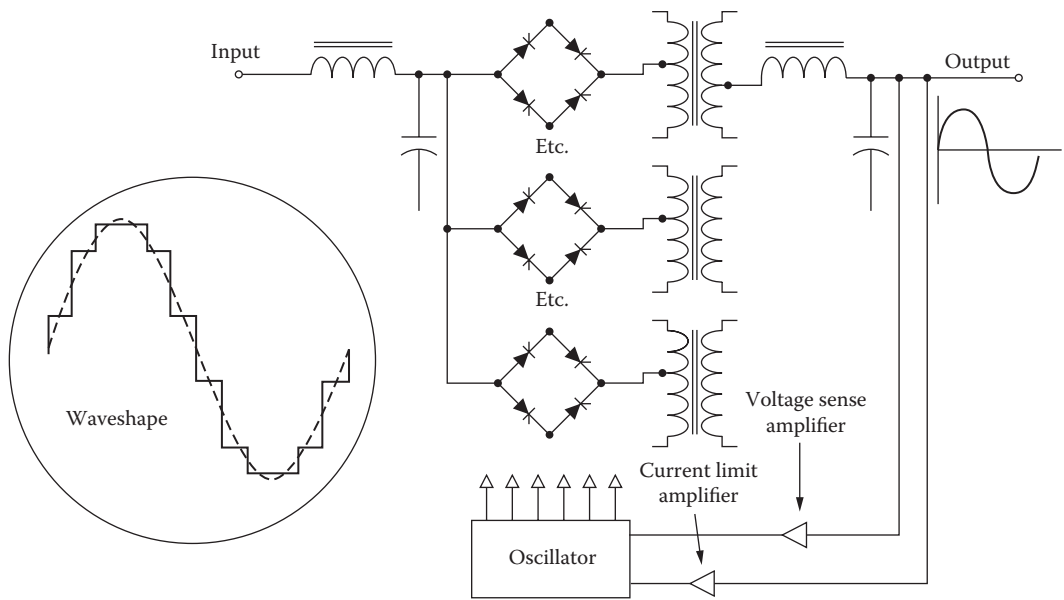


Figure 13.15 Step wave inverter and output waveform.

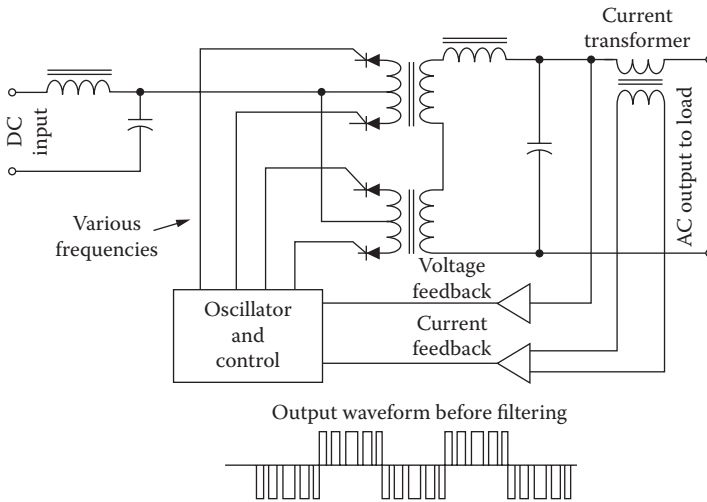


Figure 13.16 Simplified diagram of a pulse-width modulation inverter.

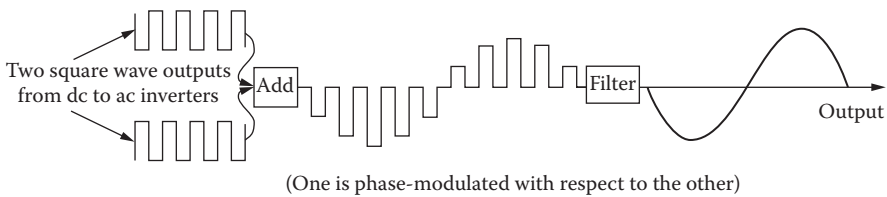


Figure 13.17 Static UPS using a phase modulated carrier. (After [1].)

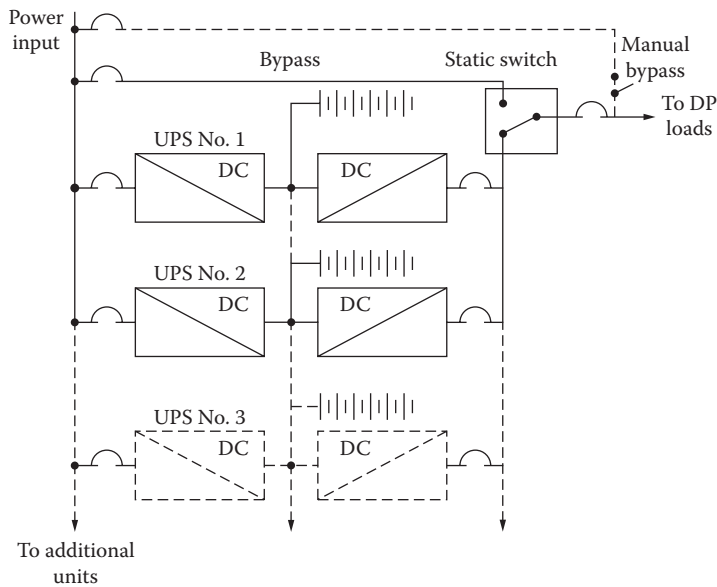


Figure 13.18 Configuration of a parallel redundant UPS system. (After [1].)

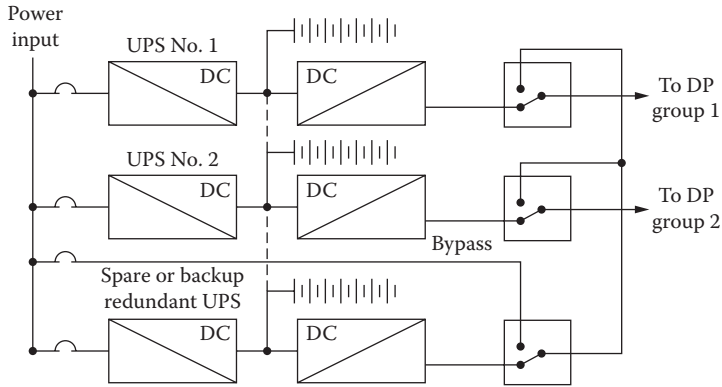


Figure 13.19 Configuration of an isolated redundant UPS system. (After [1].)

### 13.2.3 Output Transfer Switch

Fault conditions, maintenance operations, and system reconfiguration require the load to be switched from one power source to another. This work is accomplished with an output transfer switch. As discussed previously, most UPS systems use electronic (static) switching. Electromechanical or motor-driven relays operate too slowly for most DP loads. Static transfer switches can be configured as either of the following:

- *Break-before-make*: Power output is interrupted before transfer is made to the new source.
- *Make-before-break*: The two power sources are overlapped briefly so as to prevent any interruption in ac power to the load.

Figure 13.20 illustrates each approach to load switching.

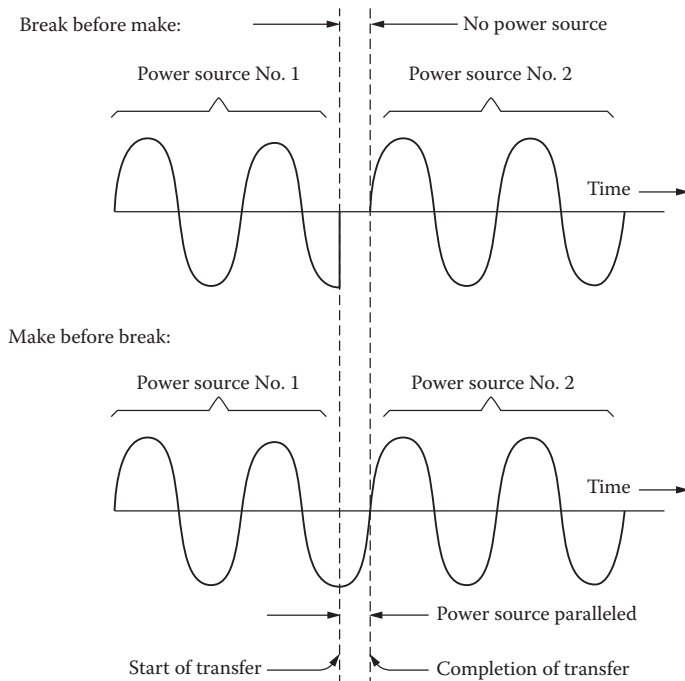


Figure 13.20 Static transfer switch modes.

For critical-load applications, a make-before-break transfer is necessary. For the switchover to be accomplished with minimum disturbance to the load, both power sources must be synchronized. The UPS system must, therefore, be capable of synchronizing to the utility ac power line (or other appropriate power source).

### 13.2.4 Battery Supply

UPS systems typically are supplied with sufficient battery capacity to carry a DP load for periods ranging from 5 min to 1 h. Long backup time periods usually are handled by a standby diesel generator. Batteries require special precautions. For large installations, they almost always are placed in a room dedicated to that purpose. Proper temperature control is important for long life and maximum discharge capacity.

Most rectifier/charger circuits operate in a *constant-current* mode during the initial charge period and automatically switch to a *constant-voltage* mode near the end of the charge cycle. This provides maximum battery life consistent with rapid recharge. It also prevents excessive battery outgassing and water consumption. The charger provides a *float voltage level* for maintaining the normal battery charge and sometimes a higher voltage to equalize certain devices.

Four battery types typically are found in UPS systems:

- *Semissealed lead calcium*. A gel-type electrolyte is used that does not require the addition of water. There is no outgassing or corrosion. This type of battery is used when the devices are integral to small UPS units, or when the batteries must be placed in occupied areas. The life span of a semissealed lead calcium battery, under ideal conditions, is about 5 years.
- *Conventional lead calcium*. The most common battery type for UPS installations, these units require watering and terminal cleaning about every 6 months. Expected lifetime ranges up to 20 years. Conventional lead-calcium batteries outgas hydrogen under charge conditions and must be located in a secure, ventilated area.
- *Lead-antimony*. The traditional lead-acid batteries, these devices are equivalent in performance to lead-calcium batteries. Maintenance is required every 3 months. Expected lifetime is about 10 years. To retain their capacity, lead-antimony batteries require a monthly equalizing charge.
- *Nickel-cadmium*. Advantages of the nickel-cadmium battery includes small size and low weight for a given capacity. These devices offer excellent high- and low-temperature properties. Life expectancy is nearly that of a conventional lead-calcium battery. Nickel-cadmium batteries require a monthly equalizing charge, as well as periodic discharge cycles to retain their capacity. Nickel-cadmium batteries are the most expensive of the devices typically used for UPS applications.

## 13.3 Reference

---

1. Federal Information Processing Standards Publication No. 94, *Guideline on Electrical Power for ADP Installations*, U.S. Department of Commerce, National Bureau of Standards, Washington, DC, 1983.

## 13.4 Bibliography

---

Lawrie, R., *Electrical Systems for Computer Installations*, McGraw-Hill, New York, 1988.

Newman, P., "UPS Monitoring: Key to an Orderly Shutdown," *Microservice Management*, Intertec Publishing, Overland Park, KS, March 1990.

Nowak, S., "Selecting a UPS," *Broadcast Engineering*, Intertec Publishing, Overland Park, KS, April 1990.

Pettinger, W., "The Procedure of Power Conditioning," *Microservice Management*, Intertec Publishing, Overland Park, KS, March 1990.

Smeltzer, D., "Getting Organized about Power," *Microservice Management*, Intertec Publishing, Overland Park, KS, March 1990.

# Power Conditioning Devices

---

## 14.1 Introduction

---

A wide variety of power-protection technologies are available to solve specific problems at a given facility. Various levels of protection can be provided using the following devices:

- Ferroresonant transformer
- Isolation transformer
- Tap-changing regulator
- Line conditioner

## 14.2 Ferroresonant Transformer

---

Ferroresonant transformers exhibit unique voltage-regulation characteristics that have proven valuable in a wide variety of applications. Voltage output is fixed by the size of the core, which saturates each half-cycle, and by the turns ratio of the windings. Voltage output is determined at the time of manufacture and cannot be adjusted. The secondary circuit resonance depends upon capacitors, which work with the saturating inductance of the device to keep the resonance active. A single-phase ferroresonant transformer is shown in [Figure 14.1](#).

Load currents tend to demagnetize the core, so output current is automatically limited. A ferroresonant transformer typically cannot deliver more than 125 to 150% of its full-load rated output without going into a current-limiting mode. Such transformers cannot support the normal starting loads of motors without a significant dip in output voltage.

Three-phase versions consisting of single-phase units connected in delta-delta, delta-wye, or wye-wye can be unstable when working into unbalanced loads. Increased stability for three-phase operation can be achieved with zigzag and other special winding configurations.

Shortcomings of the basic ferroresonant transformer have been overcome in advanced designs intended for low-power (2 kVA and below) voltage-regulator applications for DP equipment. [Figure 14.2](#) illustrates one of the more common regulator designs. Two additional windings are included:

- *Compensating winding* ( $W_c$ ), which corrects for minor flux changes that occur after saturation has been reached.
- *Neutralizing winding* ( $W_n$ ), which cancels out most of the harmonic content of the output voltage. Without some form of harmonic reduction, the basic ferroresonant transformer would be unsuitable for sensitive DP loads.

A unique characteristic of the ferroresonant regulator is its ability to reduce normal-mode impulses. Because the regulating capability of the device is based on driving the secondary winding into saturation, transients and noise bursts are clipped, as illustrated in [Figure 14.3](#).

The typical ferroresonant regulator has a response time of about 25 ms. Because of the tuned circuit at the output, the ferroresonant regulator is sensitive to frequency changes. A 1% frequency change will result (typically) in a 1.5% change in output voltage. Efficiency of the device is about 90% at full rated load, and efficiency declines as the load is reduced. The ferroresonant regulator is sensitive to leading and lagging power factors, and exhibits a relatively high output impedance.

### 14.2.1 Magnetic-Coupling-Controlled Voltage Regulator

An electronic magnetic regulator uses dc to adjust the output voltage through magnetic saturation of the core. The direct current-fed winding changes the saturation point of the transformer. This action, in turn, controls the ac flux paths through boost or buck coils to raise or lower the output voltage in response to an electronic circuit that monitors the output of the device. A block diagram of the magnetic-coupling-controlled voltage regulator is shown in Figure 14.4. Changes in output voltage are smooth, although the typical response time of 5 to 10 cycles is too slow to prevent surge and sag conditions from reaching the load.

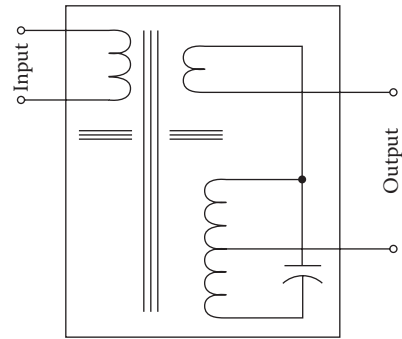


Figure 14.1 Basic design of a ferroresonant transformer. (After [1].)

Figure 14.5 illustrates an electromechanical version of a saturable regulating transformer. Output voltage is controlled by varying the impedance of the saturable reactor winding in series with a step-up autotransformer. Response to sag and surge conditions is 5 to 10 cycles. Such devices usually exhibit high output impedance and are sensitive to lagging load power factor.

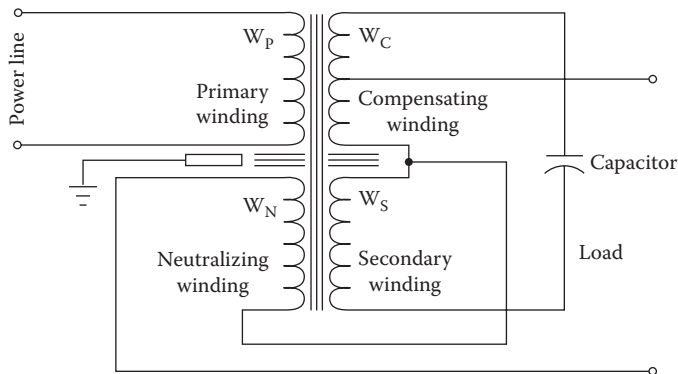


Figure 14.2 Improved ferroresonant transformer design incorporating a compensating winding and a neutralizing winding. (Adapted from documentation provided by Dranetz Technologies.)

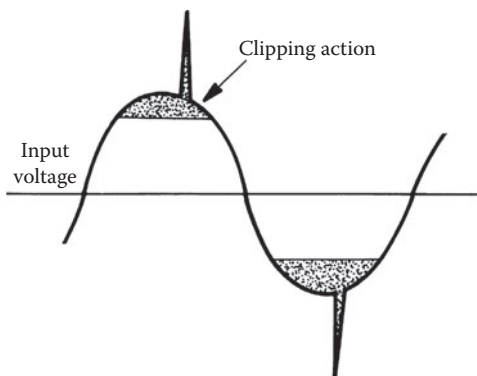


Figure 14.3 Clipping characteristics of a ferroresonant transformer.

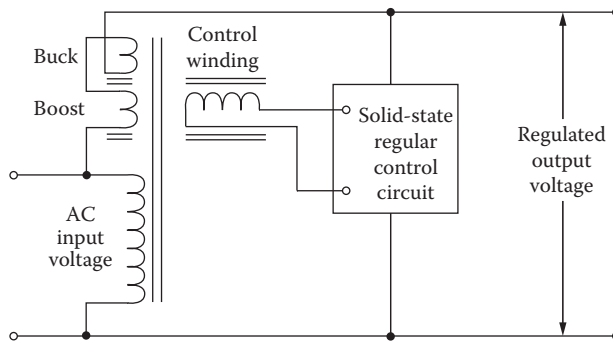


Figure 14.4 Block diagram of an electronic magnetic regulator. (After [1].)

### 14.3 Isolation Transformer

Transients as well as noise (RF and low-level spikes) can pass through transformers, not only by way of the magnetic lines of flux between the primary and the secondary, but through resistive and capacitive paths between the windings, as well. There are two basic types of noise signals with which transformer designers must cope:

- *Common-mode* noise. Unwanted signals in the form of voltages appearing between the local ground reference and each of the power conductors, including neutral and the equipment ground.
- *Normal-mode* noise. Unwanted signals in the form of voltages appearing in line-to-line and line-to-neutral signals.

Increasing the physical separation of the primary and secondary windings will reduce the resistive and capacitive coupling. However, it also will reduce the inductive coupling and decrease power transfer.

A better solution involves shielding the primary and secondary windings from each other to divert most of the primary noise current to ground. This leaves the inductive coupling basically unchanged. The concept can be carried a step further by placing the primary winding in a shielding box that shunts noise currents to ground and reduces the capacitive coupling between the windings.

One application of this technology is shown in Figure 14.6, in which transformer noise decoupling is taken a step further by placing the primary and secondary windings in their own wrapped foil box shields. The windings are separated physically as much as possible for the particular power rating and are placed between Faraday shields. This gives the transformer high noise attenuation from the primary to the secondary, and from secondary to the primary. Figure 14.7 illustrates the mechanisms involved. Capacitances between the windings, and between the windings and the frame, are broken into smaller capacitances and shunted to ground, thus minimizing the overall coupling. The interwinding capacitance of a typical transformer using this technique ranges from 0.001 to 0.0005 pF. Common-mode noise attenuation is generally in excess of 100 dB. This high level of attenuation prevents common-mode impulses on the power line from reaching the load. Figure 14.8 illustrates how an isolation transformer combines with the ac-to-dc power supply to prevent normal-mode noise impulses from affecting the load.

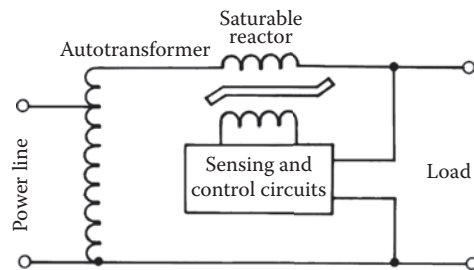
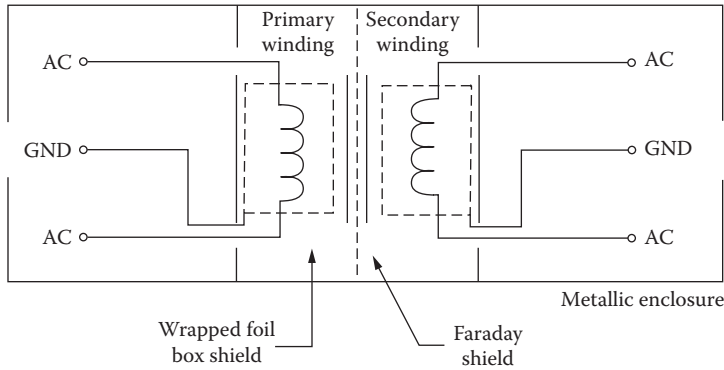
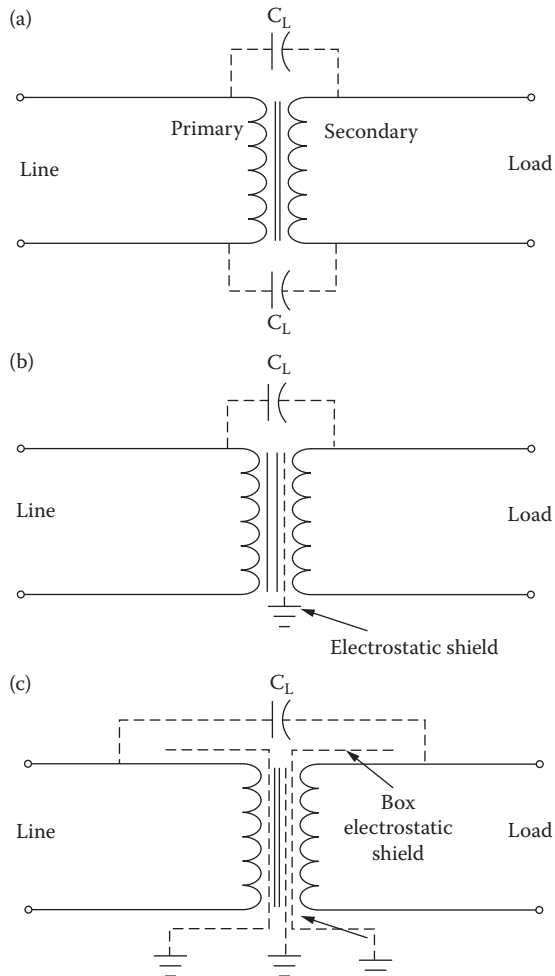


Figure 14.5 Autotransformer/saturable reactor voltage regulator.

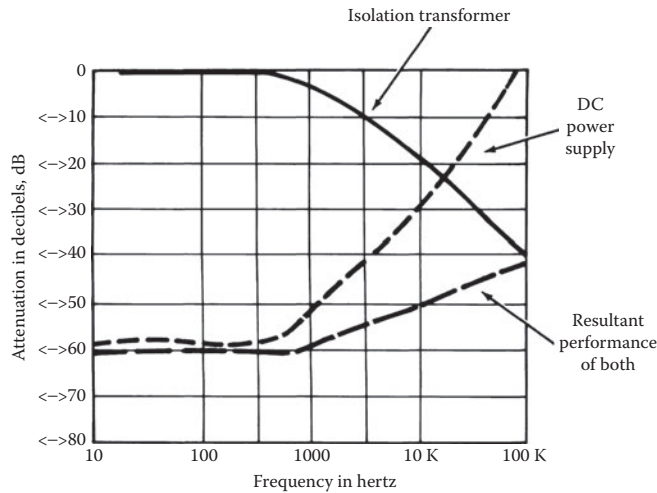




**Figure 14.6** The shielding arrangement used in a high-performance isolation transformer. The design goal of this mechanical design is high common-mode and normal-mode noise attenuation.



**Figure 14.7** The elements involved in a noise-suppression isolation transformer: (a) conventional transformer with capacitive coupling as shown; (b) the addition of an electrostatic shield between the primary and the secondary; (c) transformer with electrostatic box shields surrounding the primary and secondary windings.



**Figure 14.8** How the normal-mode noise attenuation of an isolation transformer combines with the filtering characteristics of the ac-to-dc power supply to prevent noise propagation to the load.

A 7.5 kVA noise-suppression isolation transformer is shown in Figure 14.9. High-quality isolation transformers are available in sizes ranging from 125 VA single-phase to 125 kVA (or more) three-phase. Usually, the input winding is tapped at 2.5% intervals to provide the rated output voltage, despite high or low average input voltages. The total tap adjustment range is typically from 5% above nominal to 10% below nominal. For three-phase devices, typical input-voltage nominal ratings are 600, 480, 240, and 208 V line-to-line for 15 kVA and larger.



**Figure 14.9** A 7.5 kVA noise-suppression isolation transformer. (Courtesy of Topaz.)

### 14.3.1 Tap-Changing Regulator

The concept behind a tap-changing regulator is simple: adjust the transformer input voltage to compensate for ac line-voltage variations. A tap-changing regulator is shown in Figure 14.10. Although simple in concept, the actual implementation of the system can become complex because of the timing waveforms and pulses necessary to control the SCR banks. Because of the rapid response time of SCRs, voltage adjustment can be made on a cycle-by-cycle basis in response to changes in both the utility input and the load. Tap steps are typically 2 to 3%. Such systems create no objectionable switching transients in unity power factor loads. For low-PF loads, however, small but observable transients can be generated in the output voltage at the moment the current is switched. This noise usually has no significant effect on DP loads. Other operating characteristics include:

- Low-internal impedance (similar to an equivalent transformer)
- High efficiency from full load to 25% or less
- Rapid response time (typically one to three cycles) to changes in the input ac voltage or load current
- Low acoustic noise level

An autotransformer version of the tap-changing regulator is shown in Figure 14.11.

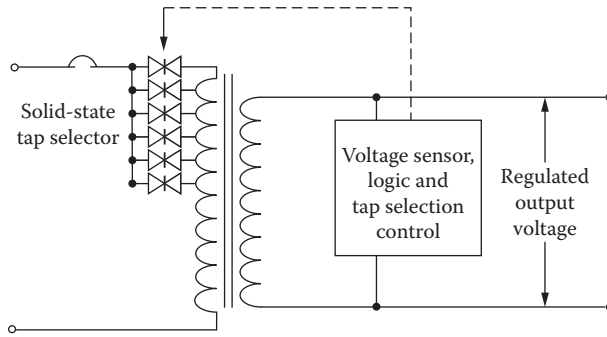


Figure 14.10 Simplified schematic diagram of a tap-changing voltage regulator. (After [1].)

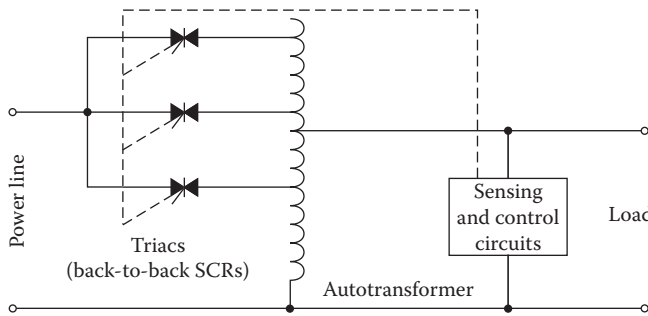


Figure 14.11 Tap-changing voltage regulator using an autotransformer as the power-control element.

**14.3.1.1 Variable Ratio Regulator**

Functionally, the variable ratio regulator is a modified version of the tap-changer. Rather than adjusting output voltage in steps, the motor-driven regulator provides a continuously variable range of voltages. The basic concept is shown in Figure 14.12. The system is slow, but generally reliable. It is excellent for keeping DP hardware input voltages within the optimum operating range. Motor-driven regulators usually are able to follow the steady rise and fall of line voltages that typically are experienced on utility company lines. Efficiency is normally good, approaching that of a good transformer. The internal impedance is low, making it possible to handle a sudden increase or decrease in load current without excessive undervoltages or overvoltages. Primary disadvantages of the variable ratio regulator are limited current ratings, determined by the moving brush assembly, and the need for periodic maintenance.

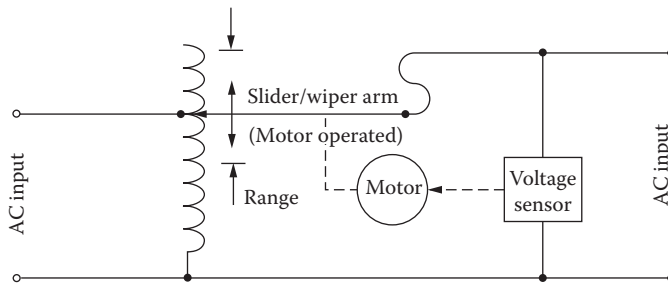
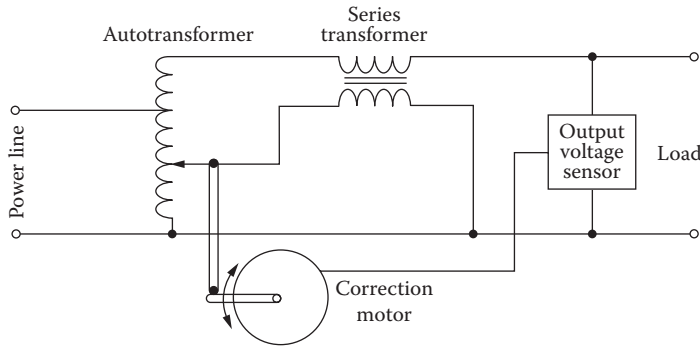


Figure 14.12 Variable ratio voltage regulator. (After [1].)



**Figure 14.13** Motor-driven line-voltage regulator using an autotransformer with a buck/boost series transformer.

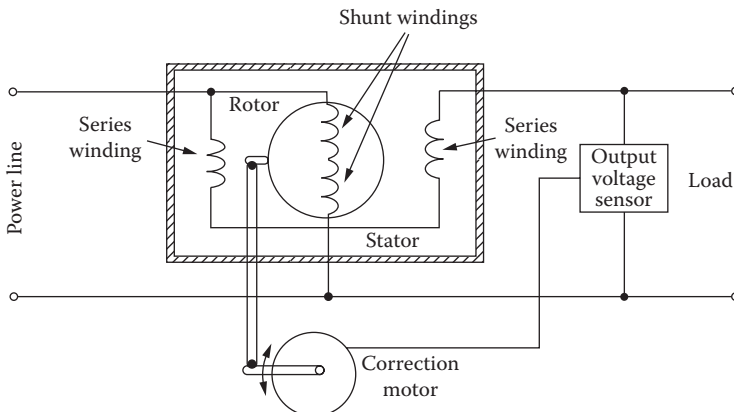
Variations on the basic design have been marketed, including the system illustrated in Figure 14.13. A motor-driven brush moves across the exposed windings of an autotransformer, causing the series transformer to buck or boost voltage to the load. The correction motor is controlled by a voltage-sensing circuit at the output of the device.

The induction regulator, shown in Figure 14.14, is still another variation on the variable ratio transformer. Rotation of the rotor in one direction or the other varies the magnetic coupling and raises or lowers the output voltage. Like the variable ratio transformer, the induction regulator is slow, but it has no brushes and requires little maintenance. The induction regulator has higher inductive reactance and is slightly less efficient than the variable ratio transformer.

### 14.3.2 Variable Voltage Transformer

Because of their application in voltage control systems, it is worthwhile to discuss the operation of variable voltage transformers in greater detail. A number of conventional transformers can have — to a limited degree — their primary/secondary ratio changed through the use of taps located (usually) on the primary windings [2]. To obtain a greater degree of flexibility in changing the ratio between the primary and secondary coils, and thus allow greater secondary voltage changes, a variable voltage transformer is used. The amount of voltage change depends upon the basic construction of the device, which typically divides into one of two categories:

- Brush type
- Induction type



**Figure 14.14** Rotary induction voltage regulator.

### 14.3.2.1 Brush Type

To achieve a variable output voltage, one tap on the transformer secondary is fixed and the other tap is connected to a brush that slides along an uninsulated section of the transformer coil [2]. One way of accomplishing this objective is to have the coil wrapped around a toroidal-shaped core. The voltage ratio relates to the location of the brush as it rides against the coil and depends upon where on the coil the brush is allowed to make contact. *Limited ratio* variable transformers are available, as well as full-range units that can adjust the output voltage from 0 to about 120% of the incoming line voltage. When the output voltage exceeds the input voltage, it means that there are extra turns on the coil that extend beyond the windings that lie between the incoming power terminals (in effect, the unit becomes a step-up transformer).

Ratings start at less than 1 kVA for a 120 V, single-phase variable transformer. Basic units are wired in parallel or in series to obtain higher power capacity. Two units in parallel have double the current and kVA rating. The individual units are stacked on top of each other, bolted together, and operated from a common shaft that rotates the brushes. Operating in a configuration that combines parallel and series connections, with several units stacked together, this type of variable voltage transformer, at 480 V, can have a rating exceeding 200 kVA. Sometimes, a control mechanism is attached to the rotor that turns the brushes, allowing automatic adjustment of the output voltage.

An important characteristic of this type of transformer relates to brush contact and the amount of current flowing through the carbon brush. A rating based solely on output kVA can cause serious operational problems because, for a given kVA load, the current drawn depends on the output voltage. Because the output voltage is variable, a load of a given kVA value can draw a safe current at 100% voltage, but at 25% voltage, the current required to serve a load of the same kVA value would require four times as much current, which could cause the brush to overheat.

### 14.3.2.2 Induction Type

The induction type variable transformer does not use brushes [2]. The usual voltage change for these units is  $\pm 10\%$ , but it can be greater. The device is essentially a variable-ratio autotransformer that uses two separate windings, a primary and a secondary. There is a laminated steel stator on which is wound a winding that serves as a secondary coil. This winding is connected in series with the load. The primary coil is connected across the supply line. The shunt winding is wound around a rotor. Construction is similar to that of a motor except that, in this case, the rotor can only turn 180 mechanical and electrical degrees.

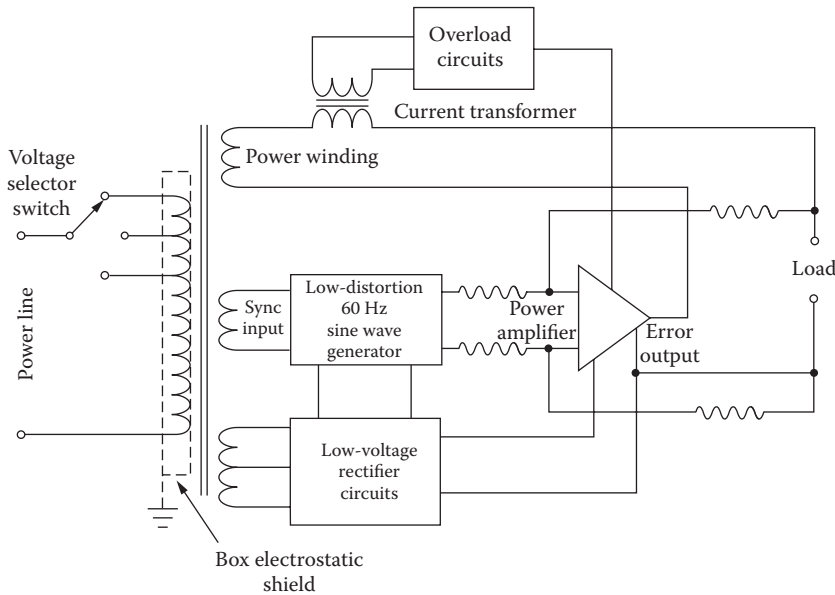
As the primary core is rotated, the amount of primary flux passing through the secondary winding is decreased until the core reaches a position at right angles to the secondary winding. In this position, no primary flux passes through the secondary windings and the induced voltage in the coil is zero. The continued rotation of the core in the same direction again increases the amount of flux passing through the secondary, but it is now in the opposite direction and so reverses the direction of the induced voltage. Thus, the output voltage can be varied by adding or subtracting from it the voltage induced in the secondary winding.

Both single- and three-phase transformers are available. Ratings of these types of transformers vary from 8 kVA, 120 V single-phase to 1500 kVA, 480 V three-phase.

## 14.4 Line Conditioner

A line conditioner combines the functions of an isolation transformer and a voltage regulator in one unit. The three basic types of line conditioners for DP applications are

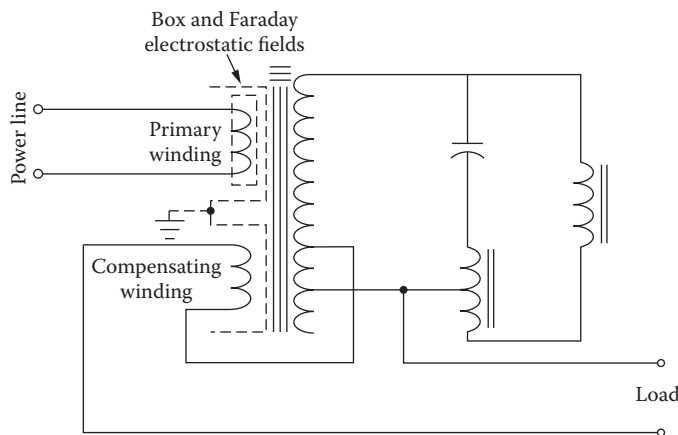
- *Linear amplifier correction system.* As illustrated in [Figure 14.15](#), correction circuitry compares the ac power output to a reference source, derived from a 60 Hz sine wave generator. A correction voltage is developed and applied to the secondary power winding to cancel noise and voltage fluctuations. A box shield around the primary winding provides common-mode impulse rejection



**Figure 14.15** Power-line conditioner using linear amplifier correction.

(80 to 100 dB typical). The linear amplifier correction system is effective and fast, but the overall regulating range is limited.

- *Hybrid ferroresonant transformer.* As shown in Figure 14.16, this system consists of a ferroresonant transformer constructed using the isolation techniques discussed in Section 15.4.2. The box and Faraday shields around the primary and compensating windings give the transformer essentially the characteristics of a noise-attenuating device, while preserving the voltage-regulating characteristics of a ferroresonant transformer.
- *Electronic tap-changing, high-isolation transformer.* This system is built around a high-attenuation isolation transformer with a number of primary winding taps. SCR pairs control voltage input to each tap, as in a normal tap-changing regulator. Tap changing also can be applied to the secondary, as shown in Figure 14.17. The electronic tap-changing, high-isolation transformer is an efficient design that effectively regulates voltage output and prevents noise propagation to the DP load.



**Figure 14.16** Line conditioner built around a shielded-winding ferroresonant transformer.

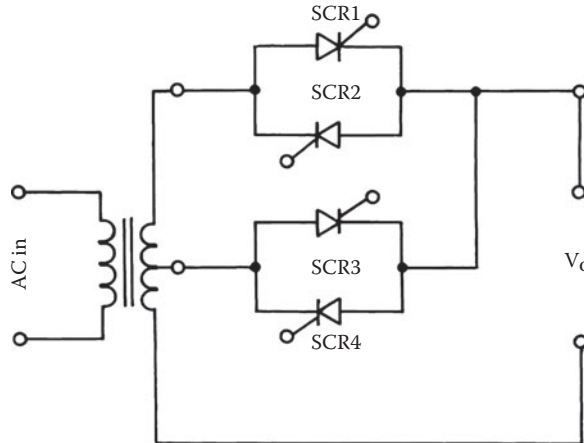


Figure 14.17 Secondary-side synchronous tap-changing transformer.

#### 14.4.1 Hybrid Transient Suppressor

A wide variety of ac power-conditioning systems are available, based on a combination of solid-state technologies. Most incorporate a combination of series and parallel elements to shunt transient energy. One such system is pictured in Figure 14.18.

#### 14.4.2 Active Power-Line Conditioner

The *active power-line conditioner* (APLC) provides an adaptive solution to many power-quality problems [3]. The major features of APLC include:

- Near-instantaneous voltage regulation
- Source voltage harmonic compensation
- Load current harmonic cancellation
- Distortion power factor correction



Figure 14.18 Interior view of a high-capacity hybrid power conditioner. (Courtesy of Control Concepts.)

The basic concept of the APLC can be expressed in mathematical terms. Figure 14.19 shows a block diagram of the APLC in a simplified power system. As shown, the system has two primary components:

- A component in series with the harmonic sensitive load, which controls the voltage sine wave being supplied by the power system
- A component in parallel with the harmonic sensitive load, which controls the harmonic current going to the load

The voltage that is supplied by the power-distribution system ( $V_{in}$ ) contains two components: the fundamental 60 Hz frequency component represented by  $V_f$  and the harmonic component of the source voltage represented by  $V_h$ . By definition,  $V_h$  is any portion of the source voltage that is not of the 60 Hz fundamental frequency. The APLC modifies this incoming voltage by adding two more voltage components:

- The  $V_h$  component, which is always equal to the  $V_h$  component of  $V_{in}$  but of the opposite polarity

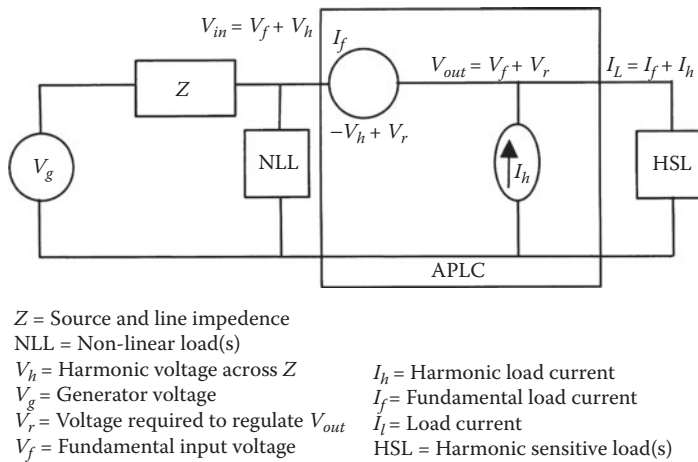


Figure 14.19 Basic conceptual diagram of the active power-line conditioner. (After [6].)

- The  $V_r$  component, which is the amount of buck or boost required to provide regulation of the output voltage

Because the two  $V_h$  components cancel, the load receives a regulated sinusoidal voltage at the fundamental frequency with no harmonic components.

The load uses current ( $I_L$ ) in a nonlinear fashion. The harmonic portion of the current  $I_h$  is — by definition — everything that is not the fundamental frequency component. The APLC becomes the source of  $I_h$  for the load circuit, leaving only the fundamental frequency portion ( $I_f$ ) to be supplied by the power system. Because the harmonic portion of the load current is supplied locally by the APLC, the distortion power factor of the load is near unity.

A digital signal processor (DSP) is used to monitor the input and output parameters of the APLC. The DSP then makes any needed adjustment in the amount of voltage compensation and current injection by modifying the switching characteristics of the insulated-gate bipolar transistors (IGBTs) in the APLC.

A simplified schematic of the APLC power circuitry is given in Figure 14.20. The dc bus ( $V_{dc}$ ) is the energy storage device that supplies the power required for voltage compensation and current injection. The parallel filter serves two purposes. First, the IGBTs in this portion of the APLC keep the dc link capacitor charged. Second, it is used as the source for the harmonic currents needed by the load. By using power from the dc link, the series filter compensates for input voltage fluctuations through the buck/boost transformer.

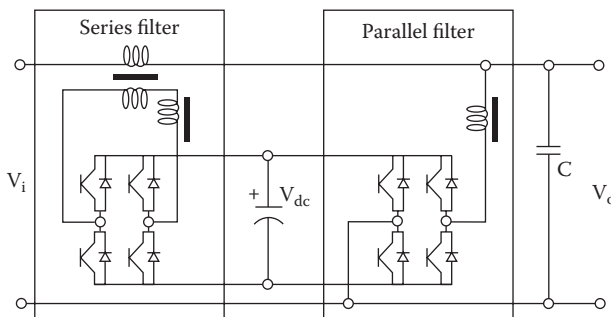


Figure 14.20 Series/parallel active power-line conditioner power control circuit. (After [6].)



#### 14.4.2.1 Application Considerations

In a conventional power control system, voltage regulation is performed by using either ferroresonant transformers or tap switching transformers. The fastest response times for either of these solutions is about one half-cycle (8 ms). This response time is the result of the tap-switching transformer's need for a zero crossing of the waveform to make a change. The use of IGBTs in the APLC allows full power to be switched at any point on the sine wave. Combining these high-speed power transistors with a fast digital signal processor, the voltage can be regulated in less than 1 ms [3]. Furthermore, the input voltage can exhibit up to 10% total harmonic distortion (THD), but output of the APLC to the load will typically see a voltage waveform with less than 1.0% THD [3].

As discussed previously, a switching power supply requires current in a nonlinear fashion. These load currents may have significant harmonic components. The APLC can cancel up to 100% load current THD at full load. The source current being supplied by the power-distribution system will see a purely linear load with no more than 3% current THD [3].

### 14.5 References

---

1. Federal Information Processing Standards Publication No. 94, *Guideline on Electrical Power for ADP Installations*, U.S. Department of Commerce, National Bureau of Standards, Washington, DC, 1983.
2. Berutti, A., *Practical Guide to Applying, Installing and Maintaining Transformers*, R. B. Morgan (ed.), Intertec Publishing, Overland Park, KS, p. 13, 1994.
3. Petrecca, R. M., "Mitigating the Effects of Harmonics and Other Disturbances with an Active Power Line Conditioner," *Power Quality Solutions*, Intertec International, Ventura, CA, 1997.

### 14.6 Bibliography

---

"How to Correct Power Line Disturbances," Dranetz Technologies, Edison, NJ, 1985.

Lawrie, R., *Electrical Systems for Computer Installations*, McGraw-Hill, New York, 1988.

*Noise Suppression Reference Manual*, Topaz Electronics, San Diego, CA.

Pettinger, W., "The Procedure of Power Conditioning," *Microservice Management*, Intertec Publishing, Overland Park, KS, March 1990.

Smeltzer, D., "Getting Organized about Power," *Microservice Management*, Intertec Publishing, Overland Park, KS, March 1990.

# 15

## Transient-Suppression Devices

---

### 15.1 Introduction

---

The performance of discrete transient-suppression components available to engineers has greatly improved within the past 10 years. The variety of reasonably priced devices now available makes it possible to exercise tight control over unwanted voltage excursions and allows the complicated electronic equipment being manufactured today to work as intended. Much of the credit for transient-suppression work goes to the computer industry, which has been dealing with this problem for more than 2 decades.

Discrete transient-suppression hardware can be divided into three basic categories:

- Filters
- Crowbar devices
- Voltage-clamping components

### 15.2 Filter Devices

---

Filters are designed to pass power-line frequency energy and reject unwanted harmonics and noise. The simplest type of ac power-line filter is a capacitor placed across the voltage source. The impedance of the capacitor forms a voltage divider with the impedance of the source, resulting in attenuation of high-frequency transients. This simple approach has definite limitations in transient-suppression capability and can introduce unwanted resonances with inductive components in the power-distribution system. The addition of a series resistance will reduce the undesirable resonant effects, but also will reduce the effectiveness of the capacitor in attenuating transient disturbances.

The conducting enclosure of an electronic device is required to be grounded for reasons of safety. However, this conductor often creates a path for noise currents. Any noise current flowing in a ground loop can create noise by electromagnetic coupling or direct connection through stray capacitances. Such noise voltages and currents are associated with the potential differences that appear throughout a large interconnected system of grounding conductors. It usually is impossible to eliminate all common-mode noise voltages in a practical ac power-distribution system. It is possible, however, to exert control over where ground loops will occur and the noise current paths that might result.

Filters intended for ac power applications are usually low-pass devices that remove high-frequency common-mode electrical noise. [Figure 15.1](#) illustrates a common filter, known as a *balun*. The balun passes the flow of normal-mode current without significant voltage drop because the power conductors, wound on a common core, are wound in opposition. Load current does not saturate the core. High-frequency noise or impulse signals appearing between the equipment ground conductor and the DP load are attenuated by the device because of the high impedance presented to the noise signals. The ground voltage offset appears across the device, where it will do no harm. Almost identical voltages also appear across the neutral and line conductor coils, thereby offsetting their voltage-to-equipment ground by the same amount as the frame-to-ground offset.

Data processing hardware usually contains line filters at the ac input point. Figure 15.2 shows several levels of complexity in *radio frequency interference* (RFI) filter design. RFI filters can be regarded as mismatching networks at high frequencies. To operate properly without interaction, filters typically are designed to operate most effectively when the input and output impedances are matched to the respective impedances of the power source and the load. These parameters are not always constant, however. Practical filters often must be designed for compromise conditions. The result may be unwanted ringing or line-voltage distortions at some frequency other than the disturbance frequency, which the filter is intended to correct.

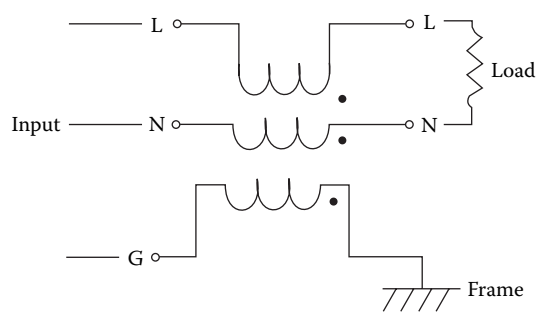


Figure 15.1 Balun common-mode filter. (After [1].)

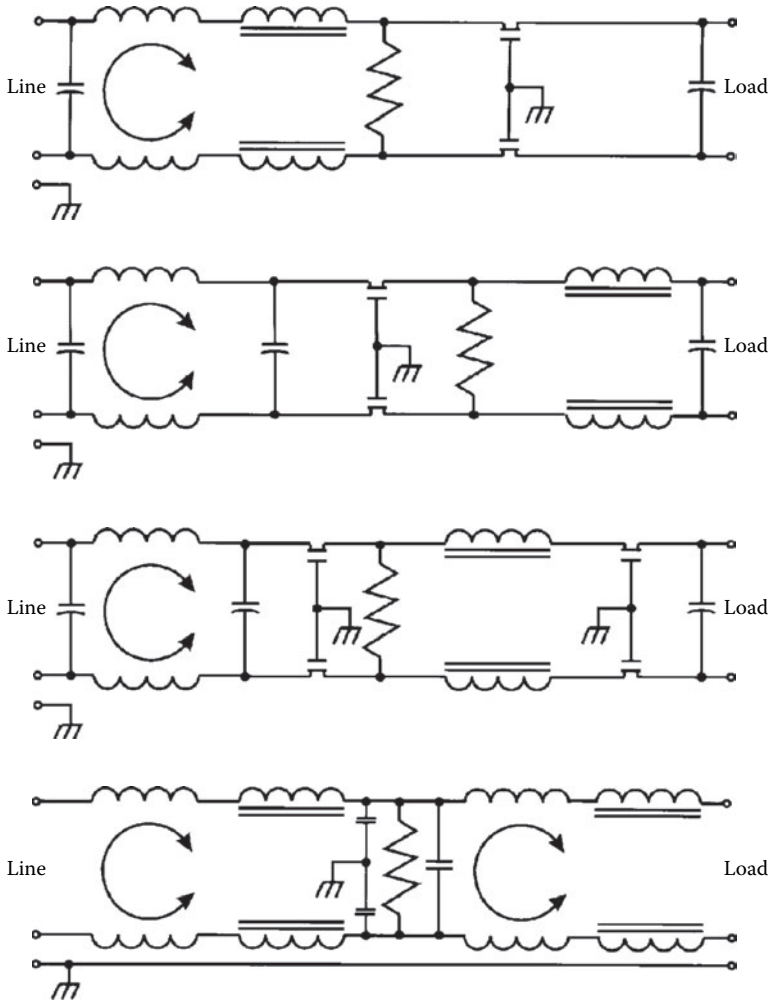


Figure 15.2 Power-line filter circuits of increasing complexity.

Filters can be composed of lumped, distributed, or dissipative elements; the type used is primarily a function of frequency. Filters, in general, are classified according to the band of frequencies to be transmitted or attenuated. The basic types illustrated in Figure 15.3 are low-pass, high-pass, bandpass, and bandstop (reject).

## 15.3 Crowbar Devices

Crowbar devices include gas tubes (also known as spark-gaps or *gas-gaps*) and semiconductor-based *active crowbar* protection circuits. Although these devices and circuits can shunt a substantial amount of transient energy, they are subject to *power-follow* problems. Once a gas tube or active crowbar protection circuit has fired, the normal line voltage *and* the transient voltage are shunted to ground. This power-follow current may open protective fuses or circuit breakers if a method of extinguishing the crowbar clamp is not provided. For example, if a short-duration impulse of a fraction of a millisecond triggers a crowbar device, the shunting action essentially would short-circuit the ac line to which it is connected for at least a half-cycle, and possibly longer. The transient created by short-circuiting the power conductor may be greater than the event that triggered it. The power-follow effect of a crowbar device is illustrated in Figure 15.4. The arc in most gas tube crowbar devices will extinguish at 20 to 30 V. It is fair to point out, however, that crowbar devices are well-suited to low source current applications, such as telco and data lines.

The most common crowbar components include pellet-type and gas-discharge-type surge arrestors. These devices usually are capable of handling high currents because the voltage drop through them becomes very low when the units are conducting.

The selection of a crowbar device, the location(s) where it can be most effective, and applicable safety precautions require a solid understanding of surge voltages and the nature of traveling pulse waves. In general, crowbar devices are most appropriate where current in an inductive circuit element can be interrupted. They also may be warranted where long cables interconnect widely separated ac systems.

### 15.3.1 Characteristics of Arcs

Defined very broadly, an arc can be described as a discharge of positive ions and electrons between electrodes in air, vapor, or both, which has a potential drop at the cathode on the order of magnitude of the minimum ionizing potential of the air, vapor, or both. A unique characteristic of an arc is the *negative resistance* effect; increasing current reduces the arc resistance. Consequently, in a given circuit, the arc voltage drop remains fairly constant, regardless of the current magnitude. Larger currents reduce the impedance, but the voltage drop remains the same. Arcs extinguish themselves at the ac zero crossing, requiring a voltage much greater than the arc voltage drop to reignite.

## 15.4 Voltage-Clamping Devices

Voltage-clamping components are not subject to the power-follow problems common in crowbar systems. Clamping devices include selenium cells, zener diodes, and varistors of various types. Zener diodes, using improved silicon rectifier technology, provide an effective voltage clamp for the protection of sensitive electronic circuitry from transient disturbances. On the other hand, power dissipation for zener units is usually somewhat limited, compared with other suppression methods.

Selenium cells and varistors, although entirely different in construction, act similarly on a circuit exposed to a transient overvoltage. Figure 15.5 illustrates the variable nonlinear impedance exhibited by a voltage-clamping device. The figure also shows how these components can reduce transient overvoltages in a given circuit. The voltage-divider network established by the source impedance  $Z_s$  and the clamping-device impedance  $Z_c$  attenuates voltage excursions at the load. It should be understood that the transient suppressor depends upon the source impedance to aid the clamping effect. A protection device cannot be fully effective in a circuit that exhibits a low source impedance because the voltage-divider ratio is reduced proportionately. It also must be recognized that voltage-clamp components divert surge

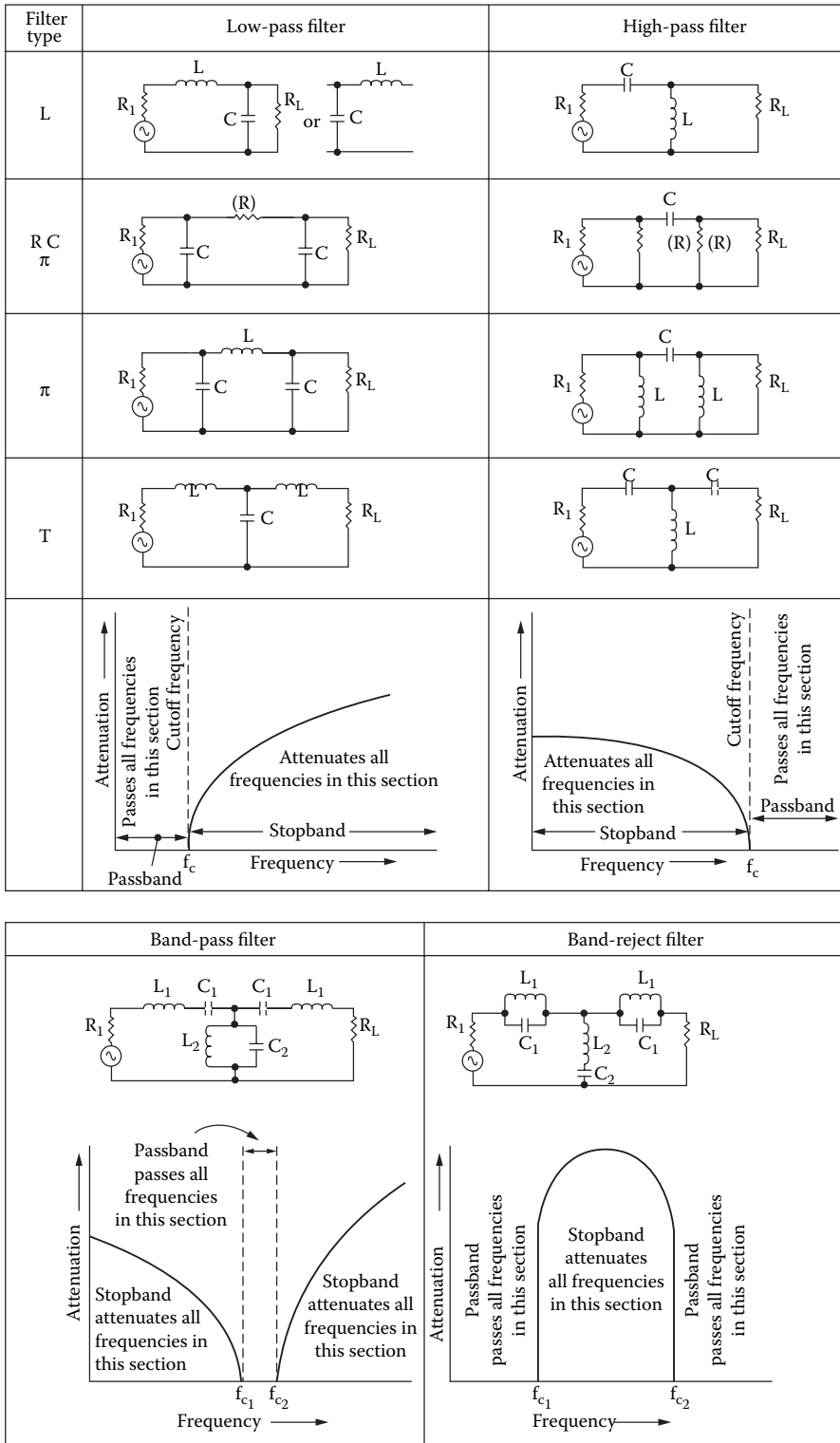


Figure 15.3 Common filter circuits, classified by function. (From [2]. Used with permission.)

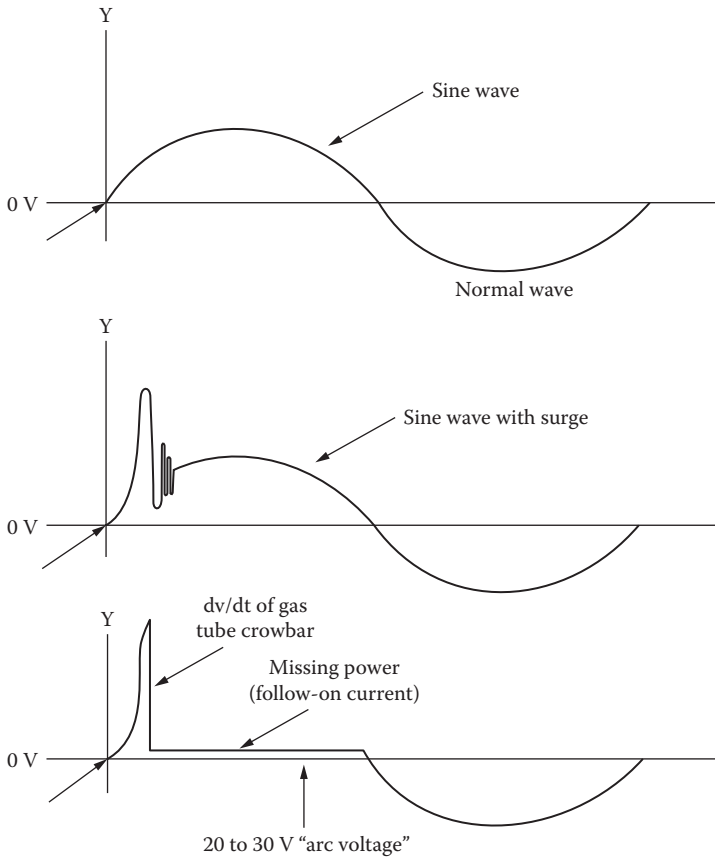


Figure 15.4 The power-follow effect of a crowbar device.

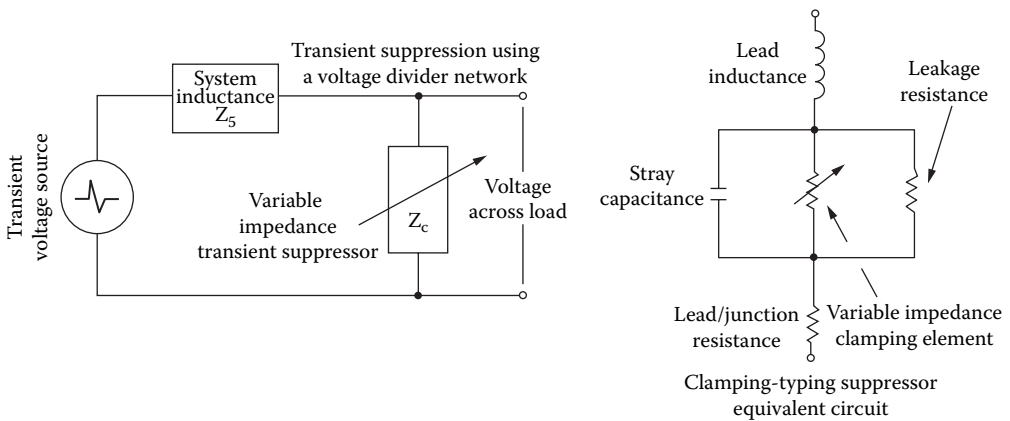


Figure 15.5 The mechanics of transient suppression using a voltage-clamping device.

currents; they do not absorb them. Care must be taken to ensure that the diversion path does not create new problems for the ac power system.

A typical voltage-vs.-current curve for a voltage-clamping device is shown in Figure 15.6. When the device is exposed to a high-voltage transient, the impedance of the component changes from a high standby value to a low conductive value, clamping the voltage at a specified level. The clamping effect common with this class of devices is illustrated in Figure 15.7.

A selenium thyrector device, intended for low- to medium-power applications, is shown in Figure 15.8. Voltage-clamping components are available in a variety of configurations, from high-power chassis-mount units to surface-mount devices designed for use on printed wiring boards. Selenium-cell transient suppressors can handle high-energy transients and repeated hits very well, but have poor voltage-clamping ability. Combination units are available, however, that use selenium devices, custom-fabricated to minimize the undesirable characteristics and to take advantage of the desirable ones. Table 15.1 compares the attributes of a variety of transient-suppression technologies.

At the clamping voltage, the clamping-device impedance goes low, but it does not fall to nearly zero, as occurs with crowbar devices [3]. There is, therefore, essentially no short-circuit magnitude follow current. Clamping voltage is maintained on the system load. The lower the source impedance, however, the more difficult it is for the clamping device to maintain system voltage without drawing excessive current.

Clamping devices operate in the nanosecond range, thousands of times faster than crowbar devices, but are generally capable of dissipating considerably less transient energy. They effectively clamp voltage spikes to a maximum level but have no effect on notches or brief dropouts.

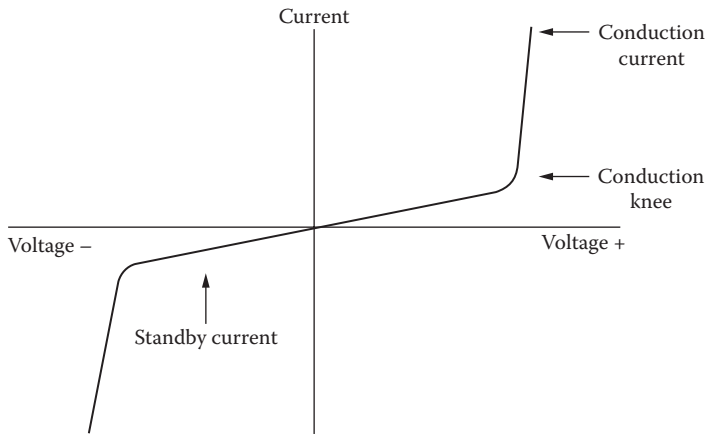


Figure 15.6 The current-vs.-voltage transfer curve for a clamping device. Note the *conduction knee*.

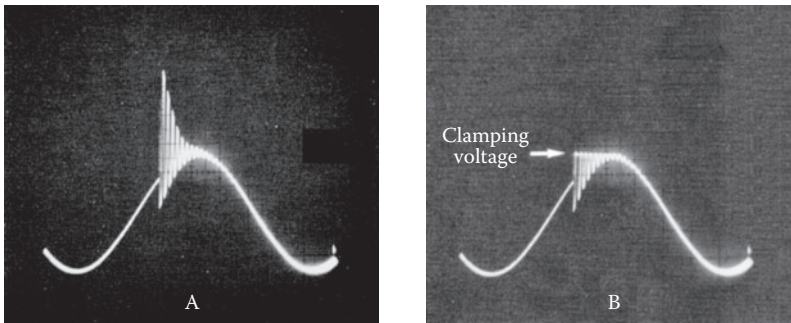


Figure 15.7 The clamping action of an MOV: (a) an oscillatory transient on the ac waveform, (b) the same waveform clamped by an MOV on the ac circuit. (From [3]. Used with permission.)

Table 15.1 Comparison of Various Transient Suppression Technologies

	Device Type	Leakage	Follow Current	Clamping Voltage	Energy Capability	Capacitance	Response Time
<p>Clamping voltage Working voltage Transient current</p>	Ideal device	Zero to low	No	Low	High	Low or high	Fast
<p>Working voltage Transient current</p>	Metal-oxide varistor	Low	No	Moderate to low	High	Moderate to high	Fast
<p>Maximum current limit Working voltage Transient current</p>	Zener diode	Low	No	Low	Low	Low	Fast
<p>Peak voltage (ignition) Working voltage Transient current</p>	Gas discharge tube	Zero	Yes	High ignition voltage Low clamp	High	Low	Slow

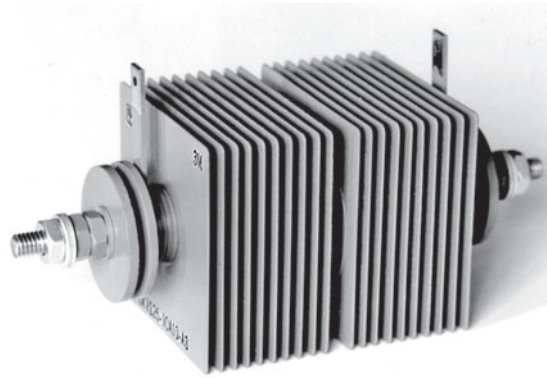


*Metal-oxide varistors* (MOVs), the most common of the clamping devices, are available for use at a wide range of voltages and currents. The range of parameters includes:

- Voltages as low as 4 V for data lines up to several thousand volts for power systems
- Peak pulse currents from a few amperes up to tens of thousands of amperes
- Energy dissipation from less than 1 to over 10,000 joules

MOVs are low in cost, compact in size, and easy to apply, and are among the most frequently used devices for transient protection. One disadvantage of the MOV is that its operating characteristics deteriorate with repeated transients. Although this problem has been reduced with improved technologies, MOV life under frequent transient conditions must be considered.

Silicon-carbide varistors have high power-handling capability and are used in high-voltage surge (lightning) arresters. The devices tend to draw considerable current in the normal state, and so they are commonly used in series with a gap that provides an open circuit until a surge occurs. This property makes silicon-carbide varistors unsatisfactory for low-voltage clamping operation. Newer zinc-oxide lightning arresters have better nonlinear characteristics and can be used without a gap. They are essentially crowbar devices, but perform almost like clamping devices.



**Figure 15.8** Selenium thyrector voltage-clamping device.

### 15.4.1 Zener Components

Zener diodes exhibit high impedance below the zener or avalanche voltage ( $V_Z$ ), and very low impedance above  $V_Z$ . Because of these clipping characteristics, the zener diode is often used to suppress transients [4]. Zeners are intolerant of excessive stress, and so it is important to know the power-handling capability for short pulse durations.

Most zeners handle less than their rated power during normal applications and are designed to operate most effectively at this low level. Zener transient suppressors (such as the Motorola 1N6267 MoSorb series), sometimes known as *silicon avalanche diodes* (SADs), typically are designed to withstand relatively large, short-duration power pulses. This is accomplished by enlarging the chip and the effective junction area to withstand high-energy surges. [Figure 15.9](#) charts the short-pulse surge capability of these devices. This data applies for nonrepetitive conditions with a lead temperature of 25°C.

It is necessary to determine the pulse width and peak power of the transient being suppressed when using [Figure 15.9](#). This can be done by taking whatever waveform the transient is and approximating it with a rectangular pulse with the same peak power. For example, an exponential discharge with a 1 ms time constant can be approximated by a rectangular pulse 1 ms wide that has the same peak power as the transient. This would be a better approximation than a rectangular pulse 10 ms wide with a correspondingly lower amplitude because the heating effects of different pulse widths affect the power handling capability of the device, as can be observed in [Figure 15.9](#). Such an approximation also represents a conservative approach because the exponential discharge will contain approximately one-half the energy of a rectangular pulse with the same pulse width and amplitude.

When used in repetitive applications, the peak power must be reduced as indicated by the curves given in [Figure 15.10](#). Average power also must be derated as the lead or ambient temperature exceeds 25°C. The power derating curve normally given on data sheets can be normalized and used for this purpose.

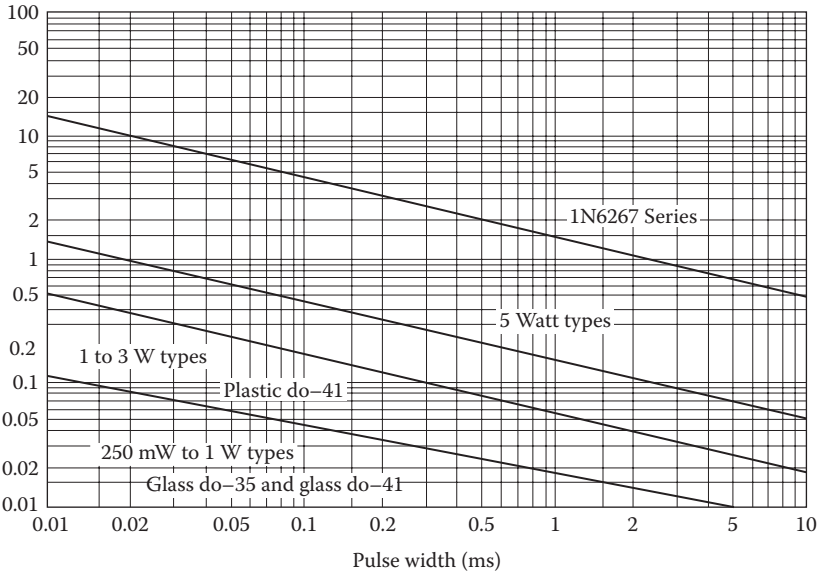


Figure 15.9 Peak power ratings of common zener diodes. (Courtesy of Motorola.)

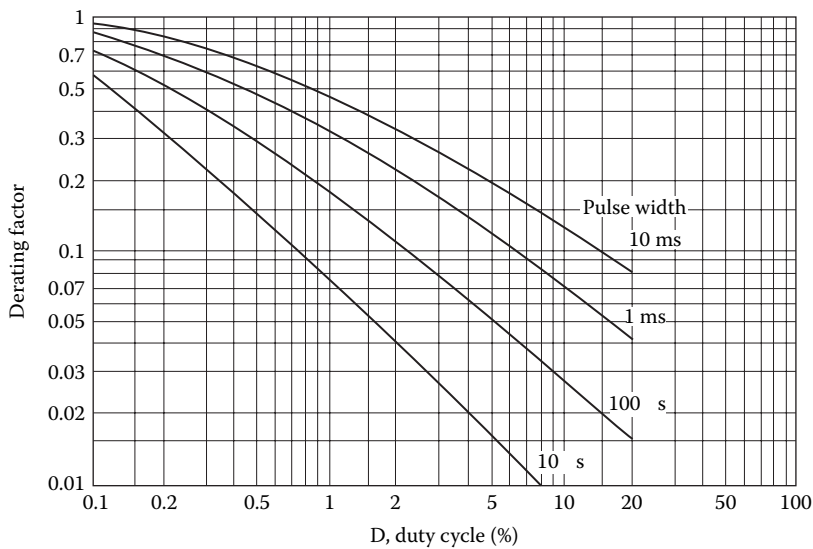
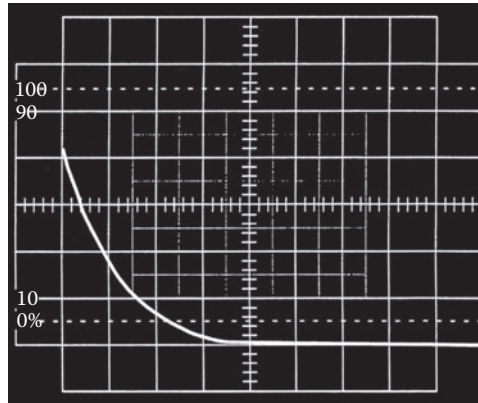


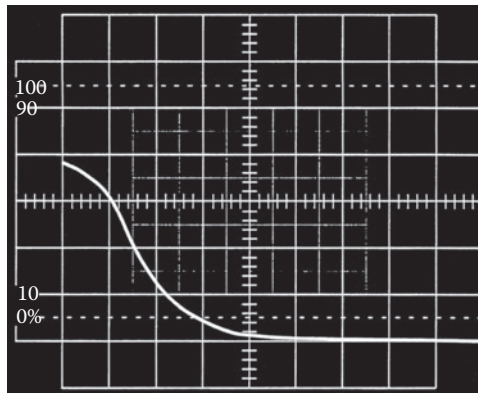
Figure 15.10 Typical derating factor for zener duty cycle. (Courtesy of Motorola.)

The clamping characteristics of zeners and MOVs are best compared by measuring their voltages under transient conditions. The waveform traces of Figure 15.11 are the result of a bench test performed to compare the clamping characteristics of a zener with those of a common MOV; both were 27 V devices. Waveform 6.11a shows the pulse generator output voltage, which synthesizes a common type of transient pulse. Waveforms 6.11b and c show the clamping voltages of the MOV and zener, respectively, with a surge source impedance of 500 Ω. As shown in the waveform traces, the zener suppressor has significantly better voltage-clamping characteristics than the MOV. The major tradeoff with using a zener-type suppressor is its cost-vs.-power handling capability.

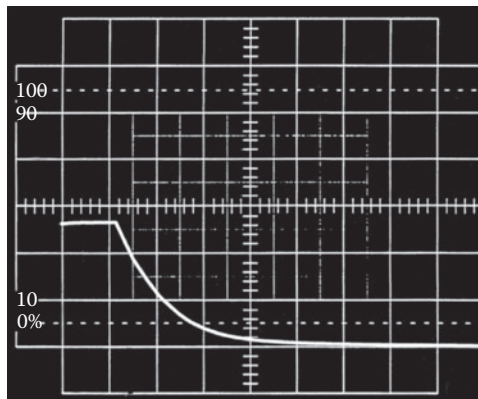
If a transient is impressed on the circuit that exceeds the capabilities of the particular zener or MOV used, the load will still be protected because both devices fail in a short circuit. The theoretical reaction



(a)



(b)

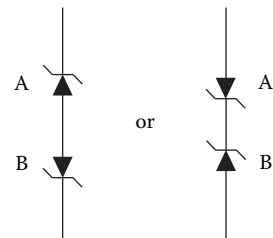


(c)

**Figure 15.11** Voltage clamping performance comparison: (a) open-circuit transient pulse, vert. = 20 V/div, horiz. = 0.5 ms/div,  $V_{\text{peak}} = 90$  V; (b) transient pulse with 27 V MOV applied, vert. = 10 V/div, horiz. = 0.5 ms/div, transient source impedance = 500  $\Omega$ ,  $V_{\text{peak}} = 39.9$  V; (c) transient pulse with 27 V zener applied, vert. = 10 V/div, horiz. = 0.5 ms/div, transient source impedance = 500  $\Omega$ ,  $V_{\text{peak}} = 27$  V. (Courtesy Motorola.)

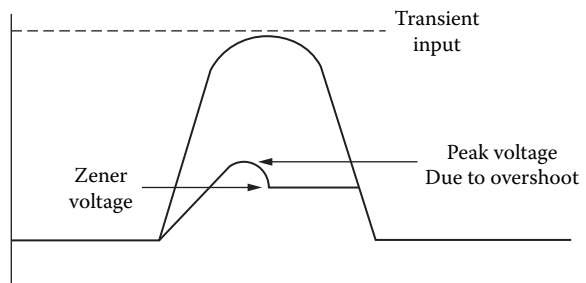
time for a zener device is in the picosecond range, but this is slowed somewhat because of lead and package inductance. For very fast rising transients, it is important, therefore, to minimize external inductances (resulting from wiring and other factors), which will minimize overshoot.

Connecting zeners in a back-to-back arrangement will enable bidirectional voltage-clamping characteristics, as illustrated in Figure 15.12. If devices *A* and *B* are of the same voltage rating, a transient of either polarity will be clamped at approximately that voltage (one zener will be reverse-bias mode while the other will be in the forward-bias mode). When clamping low voltages, it may be necessary to consider the forward voltage drop of the forward-biased zener. Bipolar zener devices also are available as packaged components.



**Figure 15.12** Zener arrangement for bidirectional clamping. (Courtesy of Motorola.)

In almost every application, the transient suppression device is placed in parallel with the load, or in parallel with the component to be protected. Because the main purpose of the circuit is to clamp the voltage appearing across the load, the suppressor should be placed as close to the load as possible to minimize overshoot resulting from wiring (or other inductive) effects. Figure 15.13 illustrates the results of inductive overshoot.



**Figure 15.13** Transient clamp overshoot resulting from inductive effects of the wiring system. (Courtesy of Motorola.)

When the zener is in the breakdown mode of operation (e.g., when suppressing a transient), its effective capacitance increases drastically from what it was in the off-state. This makes the zener ideal for parallel protection schemes because, during transient suppression, its large effective capacitance will tend to hold the voltage across the protected element constant, while in the off-state (normal conditions, no transient present), its low off-state capacitance will not attenuate high-frequency signals.

### 15.4.2 Hybrid Suppression Circuits

Any of the elements discussed so far in this chapter can be combined into a single hybrid unit to gain the best elements of each technology. A hybrid protector can be designed that will respond to several types of line disturbances. As shown in Figure 15.14, a gas tube commonly is combined with a silicon clamping device to provide two-stage suppression. When a transient hits, the clamping device will initially limit the voltage because of its faster response time, relative to the gas tube. The tube will then fire and crowbar the bulk of the energy. Proper matching of the gas tube and the clamping device is an important design parameter. If, for example, the tube is not presented with sufficient voltage to ensure that it fires, the silicon device will have to take the full surge energy, and may be destroyed in the process. The series impedance shown in the diagram can be a resistor or an inductor, or simply the interconnection impedance of the wiring system. It is sized to pass the full load current while still providing sufficient impedance to ensure that the tube will fire.

A multistage suppressor is shown in Figure 15.15. The circuit is composed primarily of metal-oxide varistors.  $V_{R1}$  and  $V_{R2}$  are the primary devices, and they absorb most of the overvoltage transients. Inductors  $L_1$  and  $L_2$  work with  $V_{R3}$  to exercise tight control over voltage excursions.

The response time of voltage-clamping devices is significantly affected by lead inductance. For this reason, lead lengths for all devices in a protection unit should be kept to a minimum.

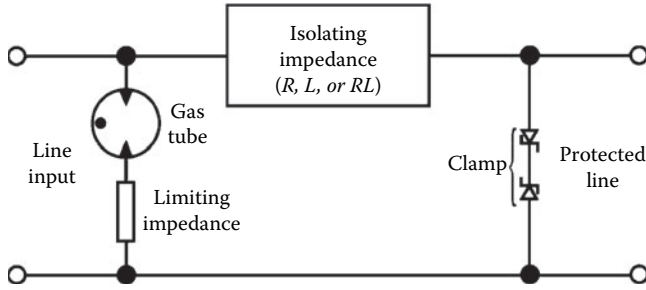


Figure 15.14 A two-stage hybrid protection circuit.

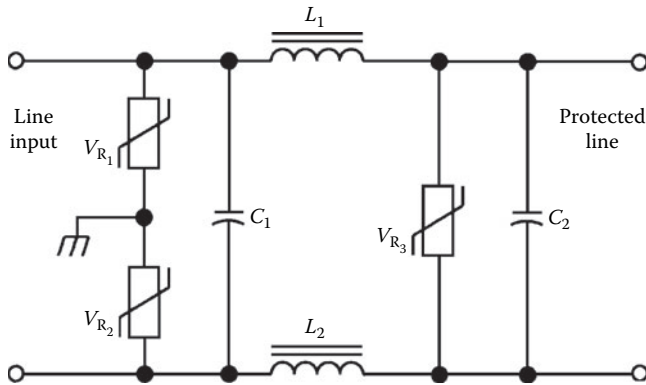


Figure 15.15 A multistage hybrid protection circuit utilizing MOVs, inductors, and capacitors.

## 15.5 Selecting Protection Components

Selecting a transient-suppression device for a given application is a complicated procedure that must take into account the following factors:

- The steady-state working voltage, including normal tolerances of the circuit
- The transient energy to which the device is likely to be exposed
- The voltage-clamping characteristics required in the application
- Circuit-protection devices (such as fuses or circuit breakers) present in the system
- The consequences of protection-device failure in a short-circuit mode
- The sensitivity of load equipment to transient disturbances

Most transient-suppression equipment manufacturers offer detailed application handbooks. Consult such reference data whenever planning to use a protection device. The specifications and ratings of suppression components are not necessarily interchangeable from one manufacturer to another. Carefully examine all variables in any planned addition of transient-suppression devices to a piece of equipment or ac power-distribution system. Make allowances for operation of the circuit under all reasonable conditions.

## 15.6 References

1. Federal Information Processing Standards Publication No. 94, *Guideline on Electrical Power for ADP Installations*, U.S. Department of Commerce, National Bureau of Standards, Washington, DC, 1983.

2. Hemming, L. H., et al., "Compatibility," in *The Electrical Engineering Handbook*, Richard Dorf (Ed.), CRC Press, Boca Raton, FL, p 914, 1993.
3. DeDad, J. A., "Surge and Transient Protection," in *Practical Guide to Quality Power for Sensitive Electronic Equipment*, A. Berutti and R. M. Waggoner (Eds.), PRIMEDIA Intertec, Overland Park, KS, pp. 39–44, 1996.
4. Motorola Application Note AN843, Motorola Semiconductor, Phoenix, AZ.

## 15.7 Bibliography

---

- Belling, M., "Judging Surge Suppressor Performance," *Microservice Management*, Intertec Publishing, Overland Park, KS, March 1990.
- Block, R., "The Grounds for Lightning and EMP Protection," PolyPhaser Corporation, Gardnerville, NV, 1987.
- Fardo, S., and D. Patrick, *Electrical Power Systems Technology*, Prentice-Hall, Englewood Cliffs, NJ, 1985.
- Fink, D., and D. Christiansen (eds.), *Electronics Engineers' Handbook*, 3rd ed., McGraw-Hill, New York, NY, 1989.
- MOV Varistor Data and Applications Manual*, General Electric Company, Auburn, NY, 1976.

# 16

## Facility Wiring and Transient Protection

---

### 16.1 Introduction

---

Most transient disturbances that a facility will experience enter the plant through the utility company ac power line. Effective transient suppression, therefore, begins with proper installation of the ac power-system wiring. If possible, arrange with the local utility to have a separate transformer feed the facility. The initial cost may be higher, but it will reduce the chances that transient disturbances from nearby operations will affect sensitive equipment. Do not allow the placement of noisy loads on the facility power line. Devices such as arc-welders, heavy electric motors, elevators, and other large loads can create an electrical environment that is prone to equipment malfunctions. It should be noted, however, that because transient disturbances, by definition, are high-frequency events, they will capacitively couple from the primary to the secondary of a typical utility company transformer. Simply installing a dedicated transformer that is not equipped with a Faraday shield (utility transformers generally do not have such shields) will not, in itself, protect equipment from potential damage. Installation of a dedicated utility transformer, however, will reduce the likelihood of problems and permit the establishment of a facility ground system independent of other users.

### 16.2 Facility Wiring

---

All ac wiring within a facility should be performed by an experienced electrical contractor and always fully within the local electrical code. Confirm that all wiring is sized properly for the load current. [Table 16.1](#) lists the physical characteristics for various wire sizes. The current-carrying capability (ampacity) of single conductors in free air is listed in [Table 16.2](#). The ampacity of conductors in a raceway or cable (three or fewer conductors) is listed in [Table 16.3](#).

Synthetic insulation for wire and cable is classified into two broad categories: (1) *thermosetting*, and (2) *thermoplastic*. A wide variety of chemical mixtures can be found within each category. Most insulation is composed of compounds made from synthetic rubber polymers (thermosetting) and from synthetic materials (thermoplastics). Various materials are combined to provide specific physical and electrical properties. Thermosetting compounds are characterized by their ability to be stretched, compressed, or deformed within reasonable limits under mechanical stress and then to return to their original shape when the stress is removed. Thermoplastic insulation materials are best known for their electrical characteristics and relatively low cost. Thermoplastics permit insulation thickness to be reduced while maintaining good electrical properties.

Many different types of insulation are used for electric conductors. The operating conditions determine the type of insulation used. Insulation types are identified by abbreviations established in the National Electrical Code (NEC). The most popular types are

- **R**: Rubber, rated for 140°F
- **RH**: Heat-resistant rubber, rated for 167°F
- **RHH**: Heat-resistant rubber, rated for 194°F
- **RHW**: Moisture- and heat-resistant rubber, rated for 167°F
- **T**: Thermoplastic, rated for 140°F
- **THW**: Moisture- and heat-resistant thermoplastic, rated for 167°F
- **THWN**: Moisture- and heat-resistant thermoplastic with nylon, rated for 194°F

**Table 16.1** Physical Characteristics of Standard Sizes of Copper Cable (at 25°C)

Wire Size (AWG/MCM)	Area (cmil)	Number of Conductors	Diameter Each Conductor	DC Resistance $\Omega$ /1000 ft	
				Copper	Aluminum
12	6,530	1	0.0808	1.6200	2.6600
10	10,380	1	0.1019	1.0180	1.6700
8	16,510	1	0.1285	0.6404	1.0500
6	26,240	7	0.0612	0.4100	0.6740
4	41,740	7	0.0772	0.2590	0.4240
3	52,620	7	0.0867	0.2050	0.3360
2	66,360	7	0.0974	0.1620	0.2660
1	83,690	19	0.0664	0.1290	0.2110
0	105,600	19	0.0745	0.1020	0.1680
00	133,100	19	0.0837	0.0811	0.1330
000	167,800	19	0.0940	0.0642	0.1050
0000	211,600	19	0.1055	0.0509	0.0836
250	250,000	37	0.0822	0.0431	0.0708
300	300,000	37	0.0900	0.0360	0.0590
350	350,000	37	0.0973	0.0308	0.0505
400	400,000	37	0.1040	0.0270	0.0442
500	500,000	37	0.1162	0.0216	0.0354
600	600,000	61	0.0992	0.0180	0.0295
700	700,000	61	0.1071	0.0154	0.0253
750	750,000	61	0.1109	0.0144	0.0236
800	800,000	61	0.1145	0.0135	0.0221
900	900,000	61	0.1215	0.0120	0.0197
1000	1,000,000	61	0.1280	0.0108	0.0177

**Table 16.2** Permissible Ampacities of Single Conductors in Free Air

Wire Size	Copper Wire with		Aluminum Wire with	
	R, T, TW Insulation	RH, RHW, TH, THW Insulation	R, T, TW Insulation	RH, RHW, TH, THW Insulation
12	25	25	20	20
10	40	40	30	30
8	55	65	45	55
6	80	95	60	75
4	105	125	80	100
3	120	145	95	115
2	140	170	110	135
1	165	195	130	155
0	195	230	150	180
00	225	265	175	210
000	260	310	200	240
0000	300	360	230	280
250	340	405	265	315
300	375	445	290	350
350	420	505	330	395
400	455	545	355	425
500	515	620	405	485
600	575	690	455	545
700	630	755	500	595
750	655	785	515	620
800	680	815	535	645
900	730	870	580	700
1000	780	935	625	750



**Table 16.3** Permissible Ampacities of Conductors in a Raceway or Cable (three or fewer conductors total)

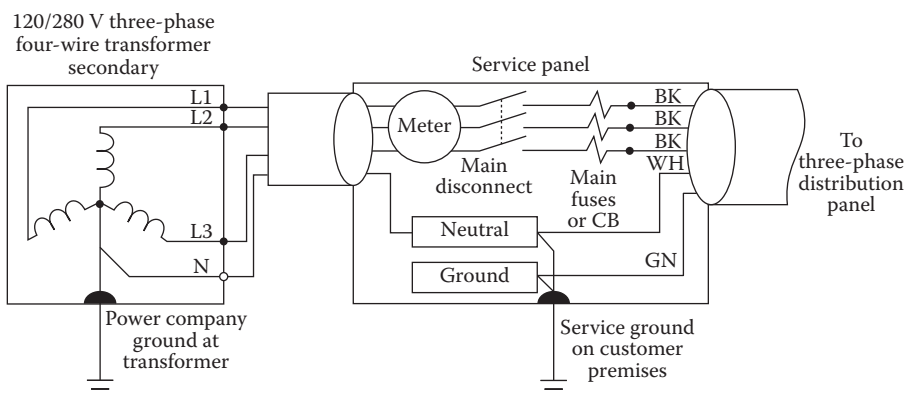
Wire Size	Copper Wire with		Aluminum Wire with	
	R, T, TW Insulation	RH, RHW, TH, THW Insulation	R, T, TW Insulation	RH, RHW, TH, THW Insulation
12	20	20	15	15
10	30	30	25	25
8	40	45	30	40
6	55	65	40	50
4	70	85	55	65
3	80	100	65	75
2	95	115	75	90
1	110	130	85	100
0	125	150	100	120
00	145	175	115	135
000	165	200	130	155
0000	195	230	155	180
250	215	255	170	205
300	240	285	190	230
350	260	310	210	250
400	280	335	225	270
500	320	380	260	310
600	355	420	285	340
700	385	460	310	375
750	400	475	320	385
800	410	490	330	395
900	435	520	355	425
1000	455	545	375	445

### 16.2.1 Utility Service Entrance

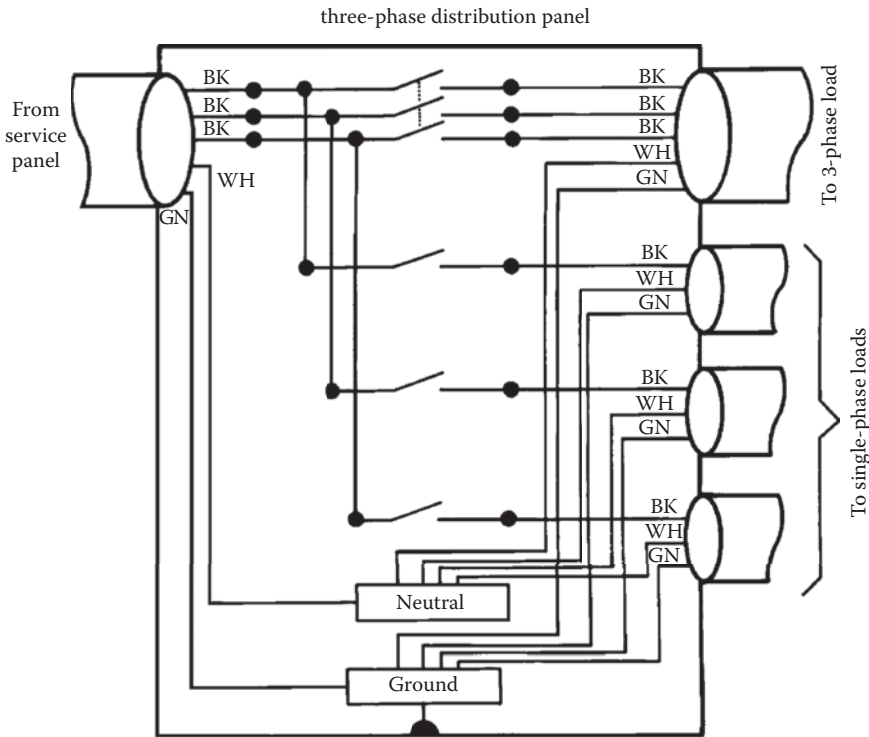
Figure 16.1 shows a typical service entrance, with the neutral line from the utility company tied to ground and to a ground rod at the meter panel. Where permitted by the local code, this should be the only point at which neutral is tied to ground in the ac distribution system.

Figure 16.2 shows a three-phase power-distribution panel. Note that the neutral and ground connections are kept separate. Most ac distribution panels give the electrical contractor the ability to lift the neutral from ground by removing a short-circuiting screw in the breaker-panel chassis. Where permitted by local code, insulate the neutral lines from the cabinet. Bond the ground wires to the cabinet for safety. Always run a separate, insulated green wire for ground. Never rely on conduit or other mechanical structures to provide an ac system ground to electric panels or equipment.

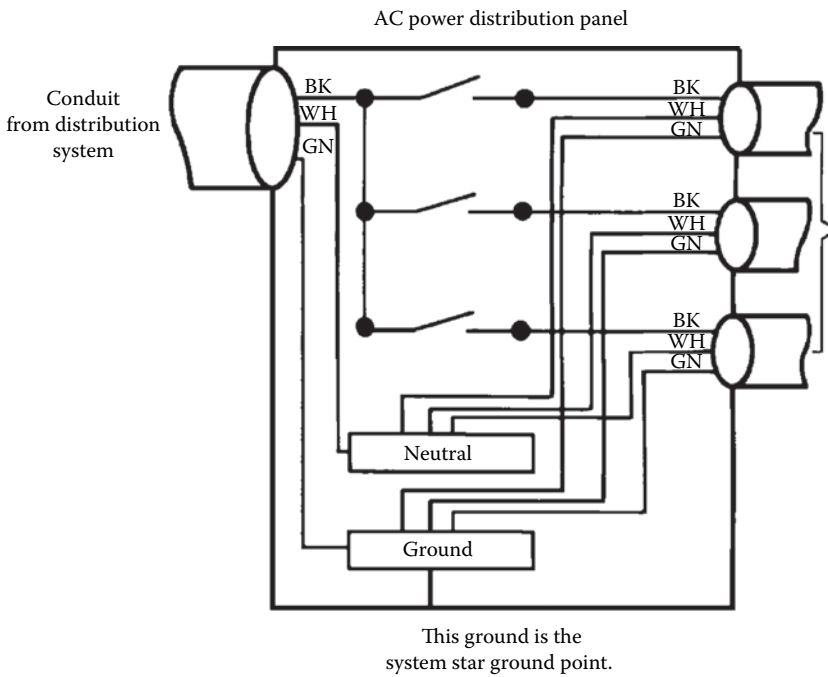
A single-phase power-distribution panel is shown in Figure 16.3. Note that neutral is insulated from ground and that the insulated green ground wires are bonded to the panel chassis.



**Figure 16.1** Connection arrangement for a three-phase utility company service panel.



**Figure 16.2** Connection arrangement of the neutral and green-wire ground system for a three-phase ac distribution panel.



**Figure 16.3** Connection arrangement of the neutral and green-wire ground system for a single-phase ac distribution panel.

Conduit runs often are a source of noise. Corrosion of the steel-to-steel junctions can act as an RF detector. Conduit feeding sensitive equipment may contact other conduit runs powering noisy devices, such as elevators or air conditioners. Where possible (and permitted by the local code), eliminate this problem by using PVC pipe, Romex, or jacketed cable. If metal pipe must be used, send the noise to the power ground rods by isolating the green ground wire from the conduit with a ground-isolating (orange) receptacle. When using an orange receptacle, a second ground wire is required to bond the enclosure to the ground system, as shown in Figure 16.4. In a new installation, isolate the conduit from building metal structures or other conduit runs. Consult the local electrical code and an experienced electrical contractor before installing or modifying any ac power-system wiring. Make sure to also secure any necessary building permits for such work.

## 16.3 Power-System Protection

Transient-protection methods for a commercial/industrial facility vary considerably, depending on the size and complexity of the plant, the sensitivity of equipment at the facility, and the extent of transient activity present on the primary power lines. Figure 16.5 shows one approach to transient suppression for a transmission facility. Lightning arresters are built into the 12 kV-to-208 V, three-phase, pole-mounted transformer. The service drop comes into the meter panel and is connected to a *primary lightning arrester* and a *primary varistor*. The circuit shown is duplicated three times for a three-wire wye (208 V phase-to-phase, 120 V phase-to-neutral) power system.

The primary arrester and varistor are placed at the service drop input point to protect the main circuit breaker and power-system wiring from high-voltage transients that are not clipped by the lightning arrester at the pole or by the varistors later in the circuit path. The primary varistor has a higher maximum clamp voltage than the varistors located after the main breaker, causing the devices downstream to carry most of the clamp-mode current when a transient occurs (assuming low system inductance). If the main circuit breaker opens during a transient disturbance, the varistor at the service drop entrance will keep the voltage below a point that could damage the breaker or system wiring.

Placing overvoltage protection before the main service breaker can be considered only when the service drop transformer feeds a single load and when the transformer has transient protection of its own, including lightning arresters and primary-side fuses. Consult the local power company before placing any transient-suppression devices ahead of the main breaker.

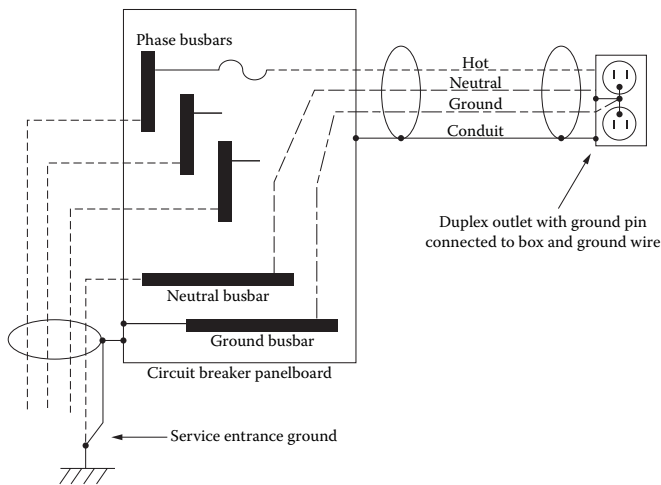
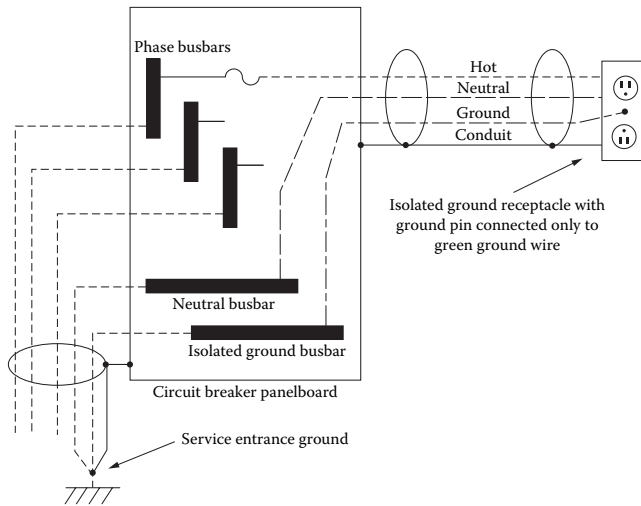
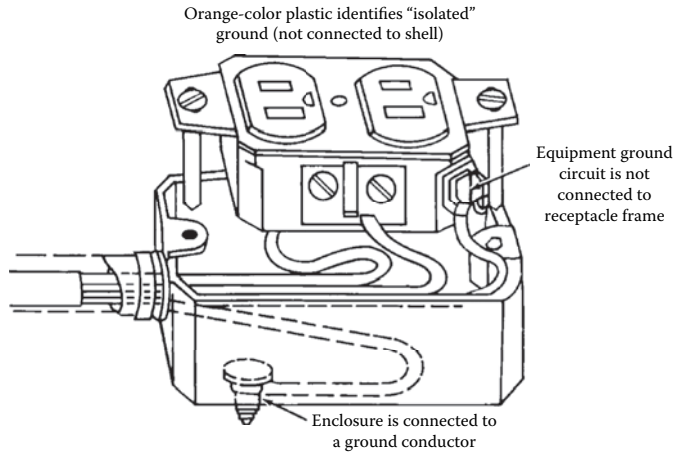
Transient protection immediately after the main breaker consists of a *secondary varistor* and a capacitor between each leg and neutral. A 47  $\Omega$ , 10 W series resistor protects the circuit if the capacitor fails. It also reduces the resonant effects of the capacitor and ac distribution-system inductance. The varistor clips overvoltages as previously described, and the resistor-capacitor network helps eliminate high-frequency transients on the line. The capacitor also places higher capacitive loading on the secondary of the utility company step-down transformer, reducing the effects of turn-on spikes caused by capacitive coupling between the primary and the secondary of the pole- or surface-mounted transformer.

As an extra measure of protection, a *supplemental varistor* and RC snubber are placed at the primary power input to the load. Transient suppressors are placed as needed at the ac power-distribution panel and circuit-breaker box.

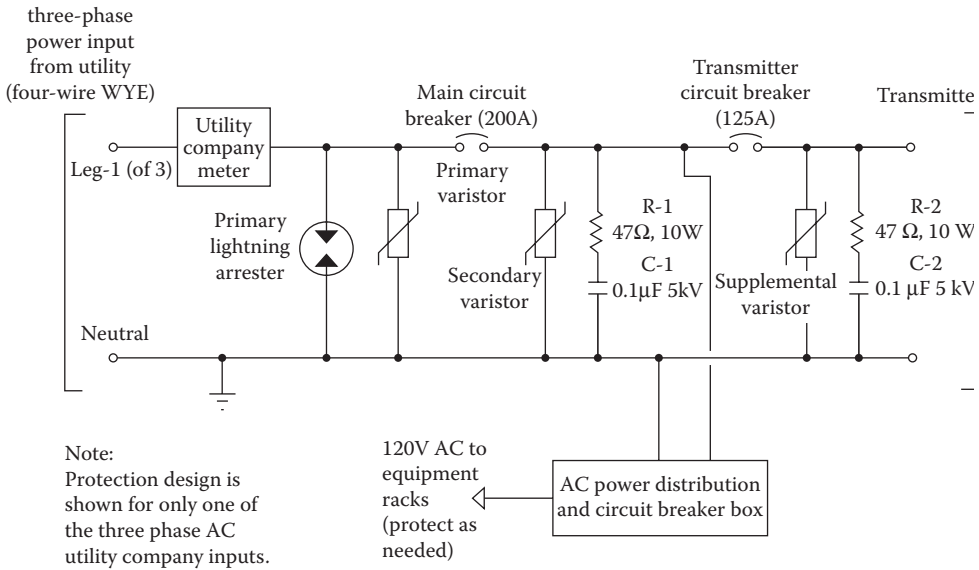
### 16.3.1 Staging

The transient-suppression system shown in Figure 16.5 uses a technique known as *staging* of protection components. An equivalent circuit of the basic system is shown in Figure 16.6. The staging approach takes advantage of the series resistance and impedance of the ac wiring system of a facility to aid in transient suppression.

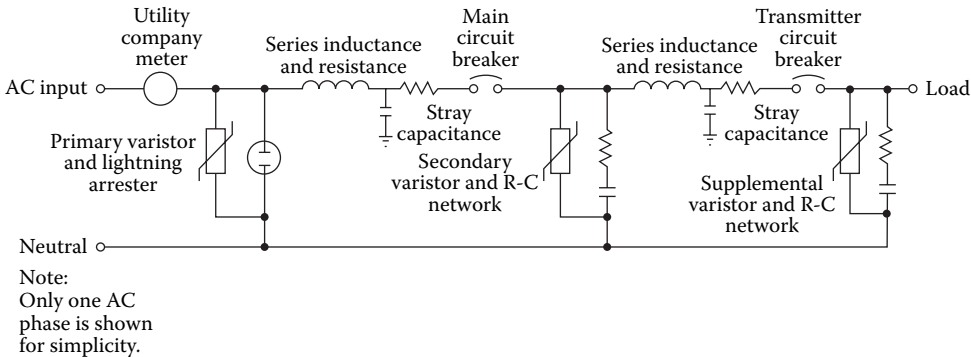
When appreciable inductance or resistance exists in an ac distribution system, the protection components located at the utility company service drop entrance (the primary suppressors) will carry most of the suppressed-surge current in the event of a lightning strike or major transient disturbance. The



**Figure 16.4** Installation requirements for an orange receptacle ac outlet: (a) mechanical configuration (note that at least two ground conductor paths are required — one for the receptacle ground pin and one for the receptacle enclosure); (b) circuit arrangement for the isolated ground outlet; (c) circuit arrangement for a conventional ac outlet. (After [1].)



**Figure 16.5** The application of transient-suppression components in a systemwide protection plan. Install such hardware with extreme care and only after consultation with the local utility company and an electrical contractor.



**Figure 16.6** The use of ac system series inductance and resistance to aid transient suppressors in controlling line disturbances. This technique is known as *staging*.

varistors and RC networks downstream (the secondary and supplemental suppressors) are rated for clamp voltages lower than the primary protection devices. With the assistance of the ac circuit series resistance and impedance, the secondary and supplemental devices exercise tight control over voltage excursions.

The staged arrangement also protects the system from exposure caused by a transient-suppression device that — for whatever reason — becomes ineffective. The performance of an individual suppression component is more critical in a system that is protected at any one point than it is in a system protected at several points. The use of staged suppression also helps prevent transients generated by load equipment from being distributed to other sections of a facility, because suppressors can be located near offending machines.

Do not place transient suppressors of the same type in parallel to gain additional power-handling capability. Even suppressors that are identical in part number have specified tolerances; devices placed in parallel will not share the suppressed-surge current equally.

### 16.3.2 Design Cautions

Install transient suppressors at the utility service entrance with extreme care and only after consulting an experienced electrical contractor and the local utility company engineering department. Protection-device failure is rare, but it can occur, causing damage to the system unless the consequences of the failure are taken into account. Before installing a surge-limiting device, examine what would happen if the device failed in a short circuit (which is generally the case). Check for proper fusing on the protected lines, and locate transient-limiting devices in sealed enclosures to prevent damage to other equipment or injury to people if device failure occurs.

In the failure mode, current through the protection device typically is limited only by the applied voltage and source impedance. High currents can cause the internal elements of the component to melt and to eventually result in an open circuit. However, high currents often cause the component package to rupture, expelling package material in both solid and gaseous forms. A transient suppressor must be fused if the line on which it is operating has a circuit-breaker (or fuse) rating beyond the point that would provide protection against package rupture of the suppressor. Selecting the fuse is a complicated procedure involving an analysis of the transient energy that must be suppressed, the rupture current rating of the suppressor, and the time-delay characteristics of the fuse. Transient-suppressor manufacturers can provide guidance on fuse selection. The monitoring circuit shown in Figure 16.7 can be used to alert maintenance personnel to an open fuse. Such provisions are important for continued safe operation of sensitive load equipment.

Lead length is another important factor to consider when installing transient-suppression components. Use heavy, solid wire (such as no. 12 AWG or larger of minimum length) to connect protection devices to the ac lines. Avoid sharp bends. If possible, maintain a minimum bending radius of 8 in. for interconnecting wires. Long leads act as inductors in the presence of high-frequency transients and as resistors when high-current surges are being clamped.

Give careful attention to proper heat-sink design when installing transient-suppression devices. Some suppressors require an external heat sink to meet their published specifications. If an adequate heat sink is not provided, the result may be premature device failure.

#### 16.3.2.1 Specifications

Transient-suppression components fail when subjected to events beyond their peak current/energy ratings. They also can fail when operated at steady-state voltages beyond their recommended values. Examine the manufacturer's product literature for each discrete protection device under consideration. Many companies have applications engineering departments that can assist in matching their product lines to specific requirements.

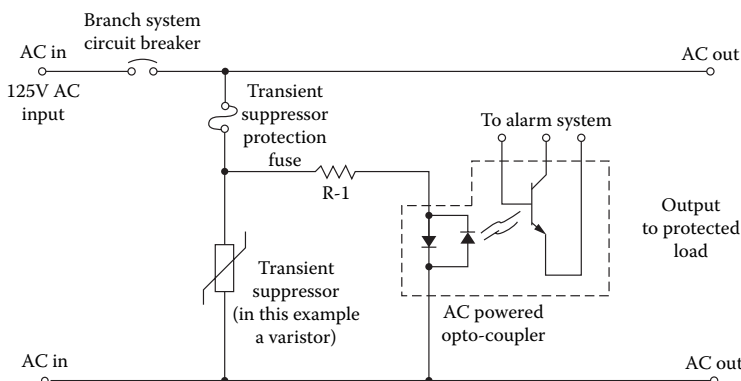
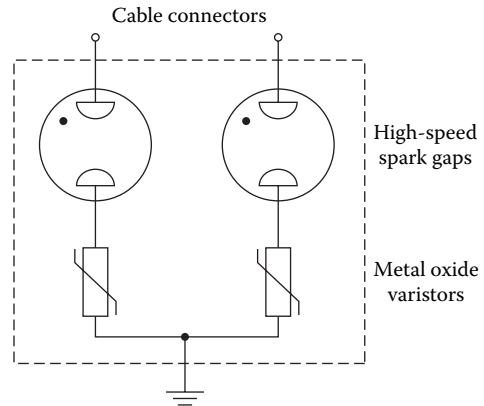


Figure 16.7 An open-fuse alarm circuit for a fused transient suppressor.

Consider using hybrid protection devices that provide increased product lifetime. For example, a varistor normally exhibits some leakage current. This leakage can lead to device heating and eventual failure. Hybrid devices are available that combine a varistor with a gas-filled spark-gap device to hold the leakage current to zero during standby operation, extending the expected product lifetime. During a transient, the spark-gap fires and the varistor clamps the pulse in the normal way. Such a device is shown in Figure 16.8. Hybrid devices of this type are immune to power-follow problems discussed in Section 6.1.2.



**Figure 16.8** A hybrid voltage-protection device incorporating a gas-tube spark-gap and varistor in each suppression element. The design goal is to extend the life of the varistors.

### 16.3.3 Single-Phasing

Any load using a three-phase ac power source is subject to the problem of *single-phasing*, the loss of one of the three legs from the primary power-distribution system. Single-phasing is usually a utility company problem, caused by a downed line or a blown pole-mounted fuse. The loss of one leg of a three-phase line results in a particularly dangerous situation for three-phase motors, which will overheat and sometimes fail. Figure 16.9 shows a simple protection scheme that has been used to protect industrial equipment from damage caused by single-phasing. At first glance, the system appears capable of easily handling the job, but operational problems can result.

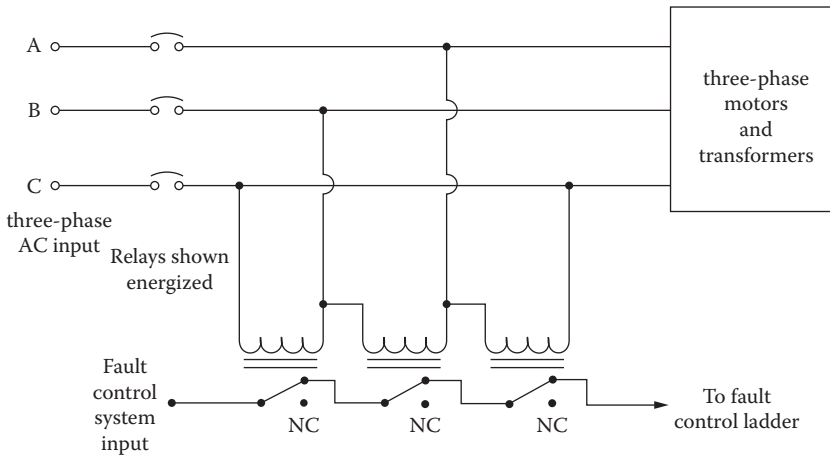
The loss of one leg of a three-phase line rarely results in zero (or near-zero) voltages in the legs associated with the problem line. Instead, a combination of leakage currents caused by *regeneration* of the missing legs in inductive loads and the system load distribution usually results in voltages of some sort on the fault legs of the three-phase supply. It is possible, for example, to have phase-to-phase voltages of 220 V, 185 V, and 95 V on the legs of a three-phase, 208 Vac line experiencing a single-phasing problem. These voltages may change, depending upon what equipment is switched on at the facility.

Integrated circuit technology has provided a cost-effective solution to this common design problem. Phase-loss protection modules are available from several manufacturers that provide a contact closure when voltages of proper magnitude and phase are present on the monitored line. The relay contacts can be wired into the logic control ladder of the protected load to prevent the application of primary ac power during a single-phasing condition. Figure 16.10 shows the recommended connection method for a high-power transmitter. Note that the input to the phase monitor module is taken from the final set of three-phase blower motor fuses. In this way, any failure inside the system that might result in a single-phasing condition is taken into account. The phase-loss protector shown in the figure includes a sensitivity adjustment for various nominal line voltages. The unit is physically small and relatively inexpensive.

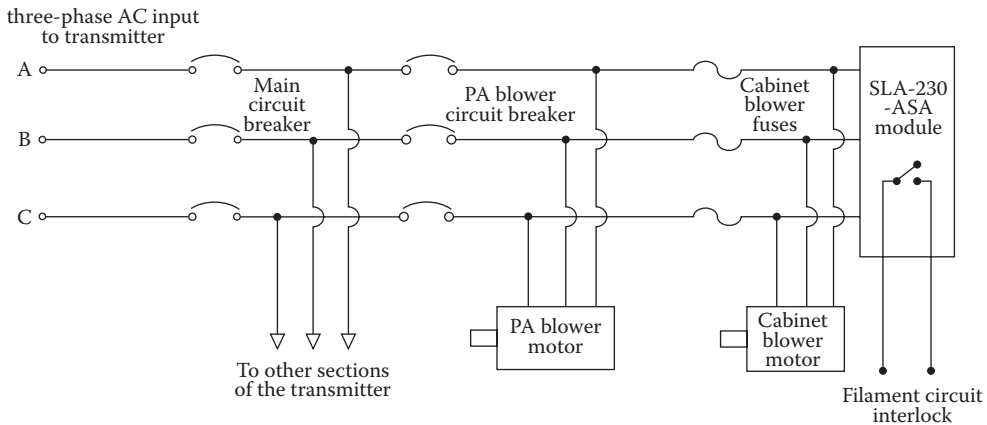
Protection against single-phasing is particularly important when transient-suppression devices are placed at the utility company service entrance. The action of suppressors can cause one or more of the fuses at the service drop transformer to open, creating a fault condition. Positive protection against continued operation of the load under such circumstances is necessary to prevent equipment failure.

### 16.3.4 Surge Suppressor Selection

Surge suppressors and lightning arresters come in all shapes, sizes, and types; a complete discussion of application methods and evaluation is beyond the scope of this chapter. Contacting surge suppressor manufacturers, however, can be confusing because of the myriad of choices available. Instead, consider contacting members of referenced IEEE, Underwriters Laboratories (UL), and IEC standard committees



**Figure 16.9** Phase-loss protection using relay logic.



**Figure 16.10** Phase-loss protection using a solid-state sensor. This circuit, used for a high-power transmitter, illustrates the importance of proper placement of the sensing device.

for help in understanding the application issues. In any event, the following general guidelines should be helpful [2]:

- Select suppressors and arresters based on IEEE C62.41 categories (A, B, or C).
- Check that the suppressors are UL 1449 tested, approved, and labeled.
- Ask for published proof of testing to back up claims, especially clamping levels, energy-handling capabilities (joules, watts, or current), and speed of response.
- Look for 3- to 5-year unconditional warranties on the products.
- Review and compare the six major performance characteristics: response time, voltage protection level, power dissipation, disturbance-free operation, reliability, and operating life. Make sure that the maximum power dissipation and voltage protection levels use specified waveforms and are stated at the same point to avoid misinterpretation.
- Talk to similar users for advice and recommendations.
- Consult industry standards for performance requirements.



## 16.4 References

---

1. Federal Information Processing Standards Publication No. 94, *Guideline on Electrical Power for ADP Installations*, U.S. Department of Commerce, National Bureau of Standards, Washington, DC, 1983.
2. Lobnitz, E. A., "Lightning Protection for Tower Structures," in *NAB Engineering Handbook*, J. C. Whitaker (Ed.), National Association of Broadcasters, Washington, DC, 1998.

## 16.5 Bibliography

---

- Belling, M., "Judging Surge Suppressor Performance," *Microservice Management*, Intertec Publishing, Overland Park, KS, March 1990.
- Block, R., "The Grounds for Lightning and EMP Protection," PolyPhaser Corporation, Gardnerville, Nev., 1987.
- Fardo, S., and D. Patrick, *Electrical Power Systems Technology*, Prentice-Hall, Englewood Cliffs, NJ, 1985.
- Fink, D., and D. Christiansen (Eds.), *Electronics Engineers' Handbook*, 3rd ed., McGraw-Hill, New York, 1989.
- McPartland, J., and B. McPartland, *National Electrical Code Handbook*, 20th ed., McGraw-Hill, New York, 1990.
- MOV Varistor Data and Applications Manual*, General Electric Company, Auburn, NY, 1976.
- Schneider, J., "Surge Protection and Grounding Methods for AM Broadcast Transmitter Sites," *Proceedings of the SBE National Convention and Broadcast Engineering Conference*, Society of Broadcast Engineers, Indianapolis, IN, 1987.

# Circuit-Level Transient Suppression

---

## 17.1 Introduction

---

The transient-suppression provisions built into professional and industrial equipment have improved dramatically over the past few years. This trend is driven by both the increased availability of high-quality transient-suppression devices and the increased need for clean power. Computer-based equipment is known for its intolerance of transient disturbances.

The transient-suppression applications presented in this section are intended only as examples of ways that protection can be built into equipment to increase reliability. End users should not attempt to modify existing equipment to provide increased transient-suppression capabilities. Such work is the domain of the equipment manufacturer. Transient suppression must be engineered into products during design and construction, not added on later in the field.

## 17.2 Protecting Low-Voltage Supplies

---

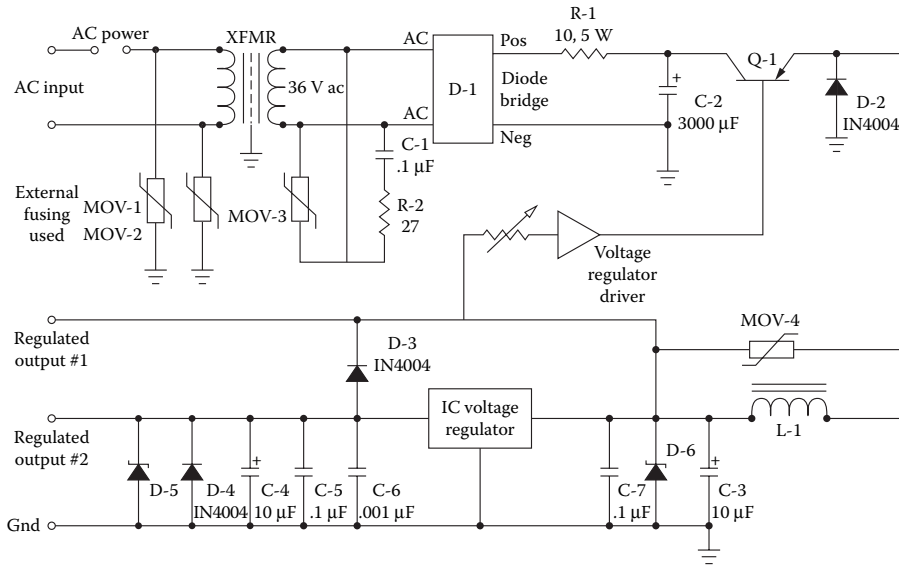
Figure 17.1 shows the recommended transient protection for a typical low-voltage series-regulated power supply. MOV1 to MOV3 clip transients on the incoming ac line. C1 aids in shunting turn-on/turn-off and fault-related disturbances on the secondary of T1. Resistor R1 protects diode bridge D1 by limiting the amount of current through D1 during turn-on, when capacitor C2 (the main filter) is fully discharged. MOV4 protects series regulator Q1 and the load from damage resulting from transients generated by fault conditions and load switching. The varistor is chosen so that it will conduct current when the voltage across L1 is greater than would be encountered during normal operation. Diode D2 protects Q1 from back-emf kicks from L1.

Three-terminal integrated circuit voltage regulator U1 is protected from excessive back-current because of a short circuit on its input side by diode D3. Capacitors C3 to C7 provide filtering and protect against RF pickup on the supply lines. Diode D4 protects U1 from back-emf kicks from an inductive load, and zener diode D5 protects the load from excessive voltage in case U1 fails (possibly impressing the full input voltage onto the load). D5 also protects U1 from overvoltages caused by transients generated through inductive load switching or fault conditions. D6 performs a similar function for the input side of U1.

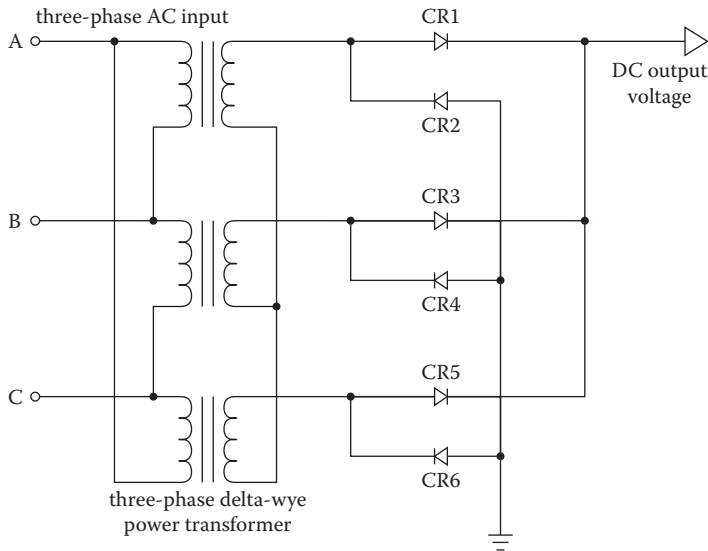
## 17.3 Protecting High-Voltage Supplies

---

A number of circuit configurations can be used for a high-voltage power supply. The most common incorporates a three-phase delta-to-wye transformer feeding a full-wave rectifier bridge, as shown in Figure 17.2. This arrangement provides high efficiency and low ripple content. With a well-balanced ac input line, the ripple component of the dc output is 4.2%, at a frequency six times the ac input frequency (360 Hz for a 60 Hz input). The dc output voltage is approximately 25% higher than the phase voltage, and each arm of the six-element rectifier must block only the phase voltage. The rms current through each rectifier element is 57% of the total average dc current of the load. The rectifier peak current is approximately equal to the value of the average dc output current. The typical power factor presented to the ac line is 95%.



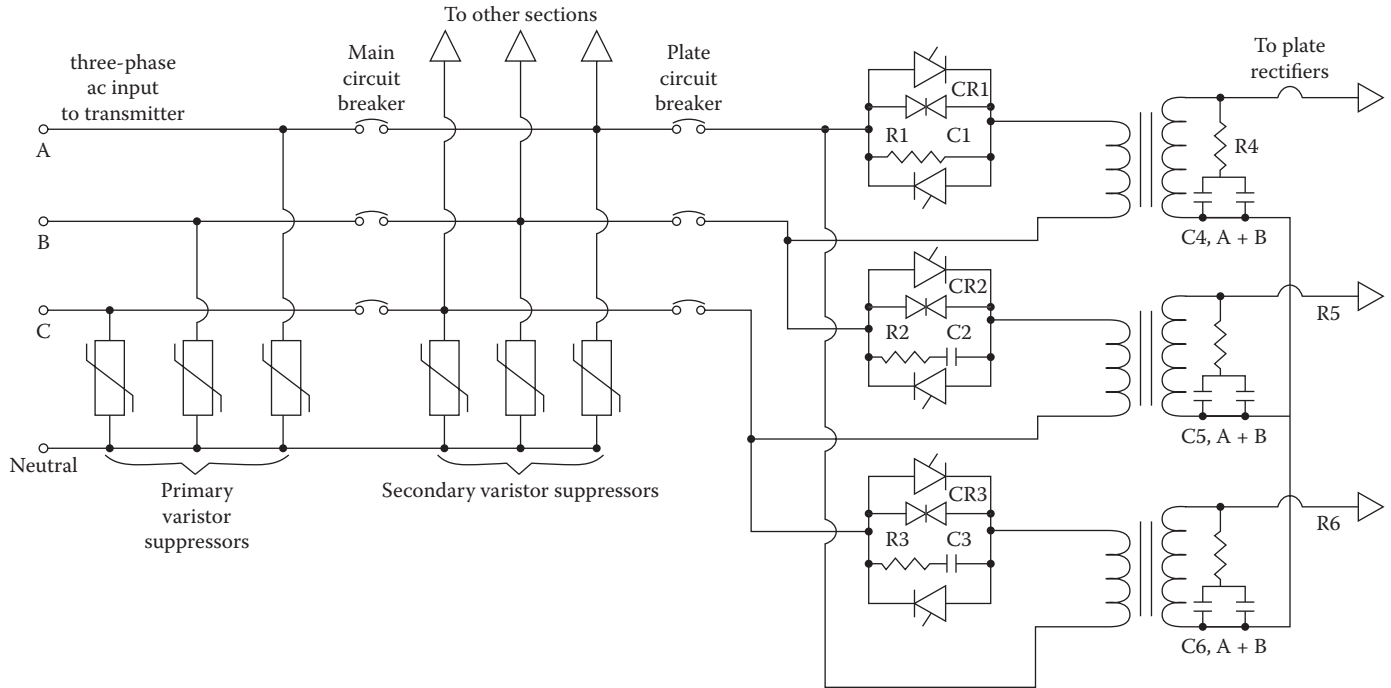
**Figure 17.1** Transient-overvoltage protection for a low-voltage power supply. A circuit such as this will survive well in the field despite frequent transient disturbances.



**Figure 17.2** Three-phase full-wave bridge rectifier circuit.

Figure 17.3 illustrates the application of device staging to protect a high-voltage power supply from transient disturbances. As detailed previously for ac distribution systems, staging takes advantage of the series resistance and inductance of interconnecting wiring to assist in suppressing transient disturbances. The circuit includes two sets of varistors: primary and secondary units. The secondary set is rated for a lower clamp voltage and, together with the primary varistor groups, exercises tight control over disturbances entering the supply from the ac utility input.

Additional transient-suppression devices (CR1 to CR3) and three sets of RC snubbers (R1/C1 to R3/C3) clip transients generated by the power transformer during retarded-phase operation. On the transformer secondary, three groups of RC snubbers (R4/C4a-b to R6/C6a-b) provide additional protection to the load from turn-on/turn-off spikes and transient disturbances on the utility line.



**Figure 17.3** The use of ac system series inductance and resistance to aid transient suppressors in controlling line disturbances in a high-power transmitter.

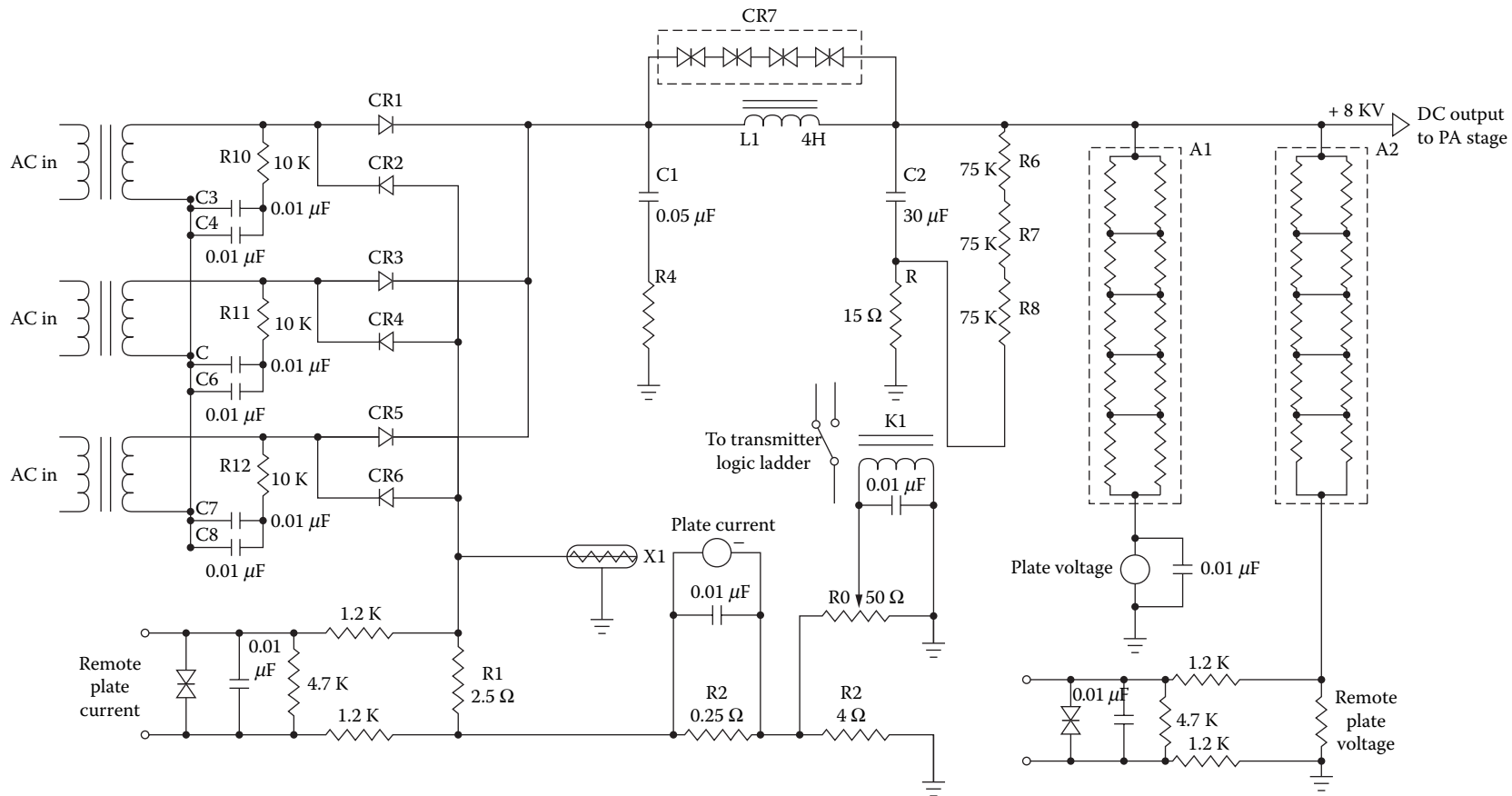


Figure 17.4 High-voltage power supply incorporating transient-suppression devices.

Figure 17.4 shows the secondary side of a high-voltage power supply incorporating transient-over-voltage protection. RC networks are placed across the secondary windings of the high-voltage transformer, and a selenium thyrector (CR7) is placed across the choke. CR7 is essentially inactive until the voltage across the device exceeds a predetermined level. At the *trip point*, the device will break over into a conducting state, shunting the transient overvoltage. CR7 is placed in parallel with L1 to prevent damage to other components in the system in the event of a sudden decrease in current drawn by the load. A sudden drop in load current will cause the stored energy of L1 to be discharged into the power supply and load circuits in the form of a high potential pulse. Such a transient can damage or destroy filter, feedthrough, or bypass capacitors. It also can damage wiring or cause arcing. CR7 prevents these problems by dissipating the stored energy in L1 as heat. Figure 17.5 shows an internal view of the high-power transmitter supply illustrated in Figure 17.4.

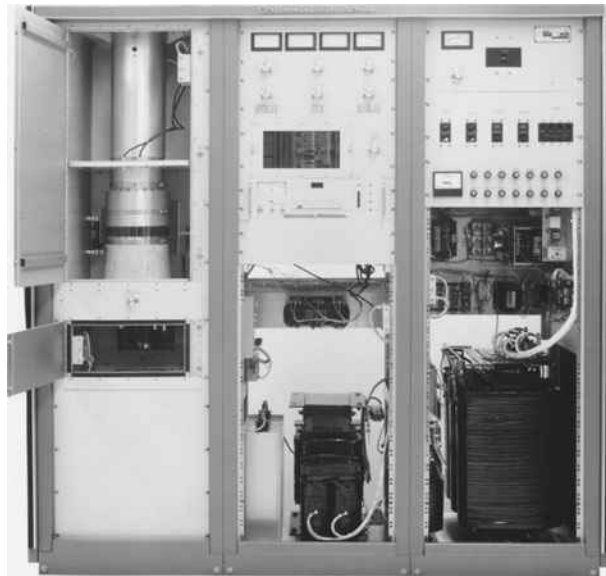


Figure 17.5 Interior view of a high-power transmitter showing the principal power supply components. (Courtesy of Continental Electronics.)

## 17.4 RF System Protection

A common method of protecting an ungrounded transmitting tower (used for AM broadcasting) is shown in Figure 17.6. Two forms of protection are used. The first combines the effects of a one-turn loop and lightning ball gaps to shunt lightning discharges to ground. The loop adds inductance to retard the advance of the lightning current into the *antenna tuning unit* until the ball gaps have fired (arced-over). The second protective element is the *gas-gap* device installed within the antenna tuning unit, which conducts whenever the voltage at its terminals exceeds a specific potential. The current-limiting fuse protects the transmission system from the effects of power follow-on and the possibility of gas-gap failure in a short-circuit. A static drain choke, also shown in the figure, serves to maintain the tower at dc ground to bleed off the buildup of static electricity on the tower structure.

## 17.5 Protecting Logic Circuits

For maximum protection of microcomputer equipment, transient suppression must be designed into individual circuit boards. Figure 17.7 illustrates a typical application of on-the-board transient suppression. Multiple voltage-clamping devices are included in a single DIP package, making it possible to

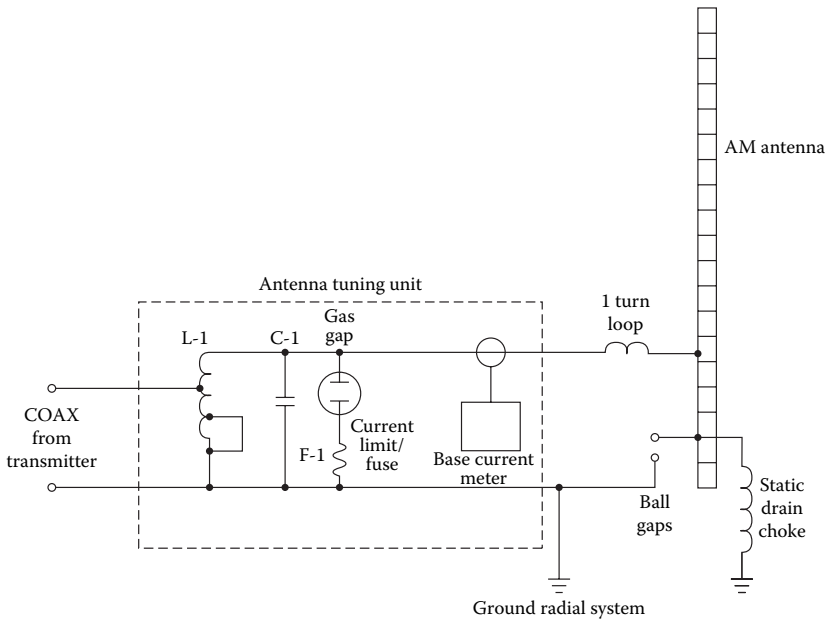


Figure 17.6 Common lightning protection methods for an ungrounded transmitting tower.

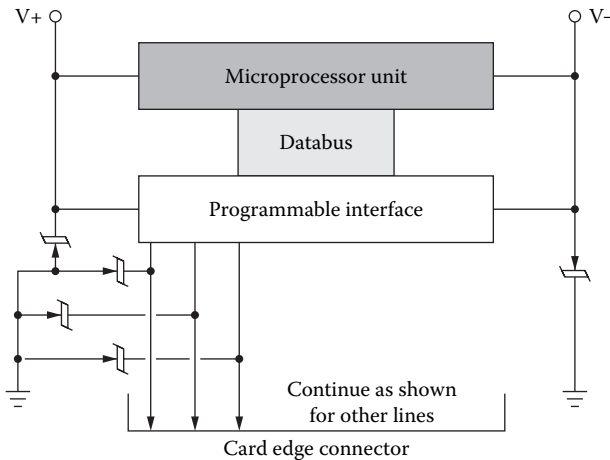
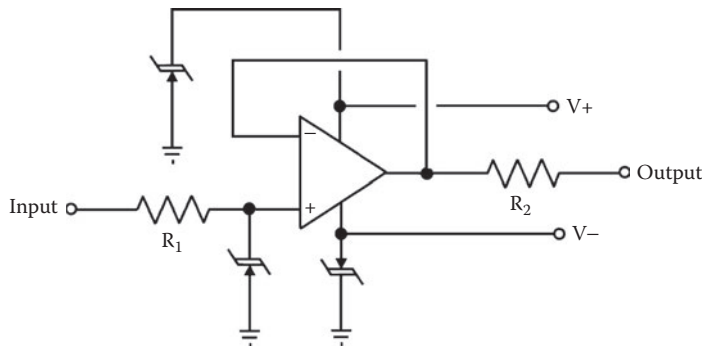


Figure 17.7 Application of transient-suppression devices to microcomputer circuits.

conveniently include protection on individual printed wiring boards. Figure 17.8 shows the application of transient suppressors in a voltage-follower circuit, common in many data-acquisition systems. Note the use of suppression devices at the power-supply pins of the circuits shown in the figures.

## 17.6 Protecting Telco Lines

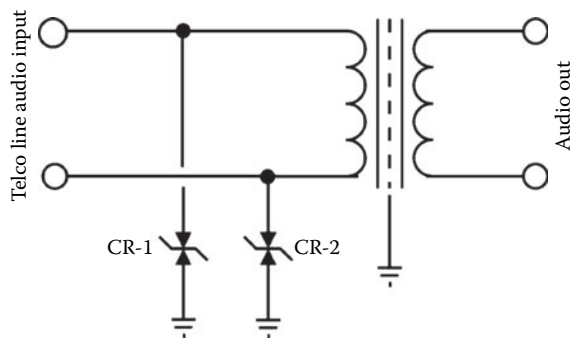
Communication lines that travel from the telephone company (telco) central office (CO) to customer sites require transient protection. Furthermore, lines that travel from one building to another, or from one floor to another, also may be exposed to a transient threat. Problems can result whether the lines are twisted pairs or coaxial cable.



**Figure 17.8** Application of transient-suppression devices to an analog voltage sampling circuit.

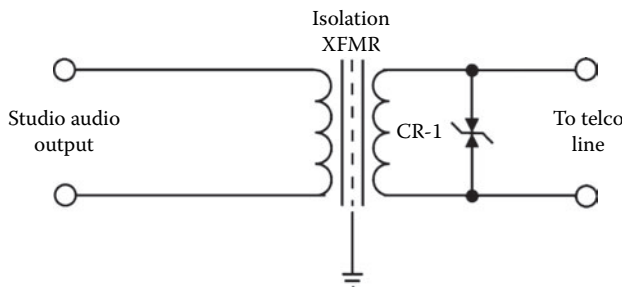
The *gas tube* is the traditional protection element installed at the telco central office. The primary purpose of the gas tube (and its carbon predecessor) is to protect CO personnel from injury and CO equipment from damage in the event of a lightning flash to exposed lines or accidental contact with high-voltage utility company cables. Protection devices usually are included at the telco service entrance point on the customer's premises. Telco providers do their best to ensure that disturbances do not reach customers, but the final responsibility for transient protection lies with the equipment user.

Solid-state voltage-clamping devices generally are used to protect audio and data lines. The transient-clipping devices shown in Figure 17.9 are selected based on the typical voltage levels (including headroom) used on the loop. Figure 17.10 illustrates another protection arrangement, which prevents the introduction of noise into audio or data lines because of a common-mode imbalance that may result from transient suppressors being tied to ground. The use of a low-capacitance suppressor ensures minimum capacitive loading on the circuit.



**Figure 17.9** Application of transient-suppression devices to an audio distribution circuit.

For balanced telco lines, critical transient considerations include both the above-ground voltage of the two conductors (the common-mode voltage) and the voltage between the two conductors (the normal-mode voltage). When individual clamping devices are used on each conductor, as shown in Figure 17.9, one device will inevitably clamp before the other. This action can create a significant voltage differential that can damage sensitive equipment on the line. A common solution is the three-element gas tube. The device has a single gas chamber

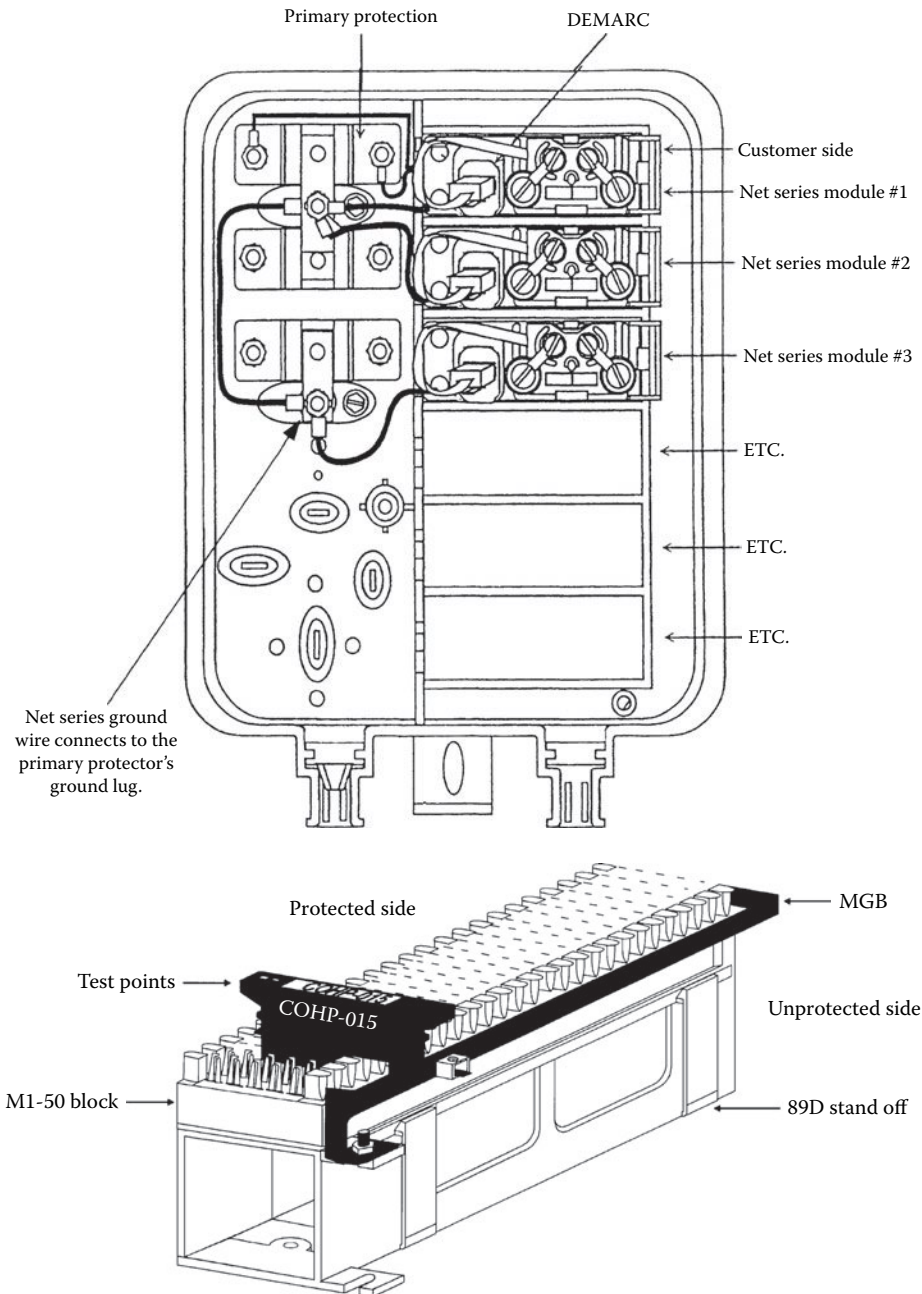


**Figure 17.10** Application of a transient-suppression device to a telephone company audio or data line.



with two gaps, one for each side of the line. When one side reaches the ionization potential, both sides fire simultaneously to ground.

Transient-suppression devices for low-voltage telco and data circuits are available from a number of manufacturers in a variety of configurations. Figure 17.11 illustrates some of the more common implementations.



**Figure 17.11** Telco and low-voltage surge protection: (a) telco service entrance device, (b) connection block protection device. (Courtesy of Control Concepts.)

## 17.7 Inductive Load Switching

Any transistor that switches an inductive load must be provided with transient protection. Figure 17.12 shows the most common approach. Protection also is required for switches that control an appreciable amount of power, as illustrated in Figure 17.13. The use of a transient suppressor across switch or relay contacts will also extend the life of the switching elements.

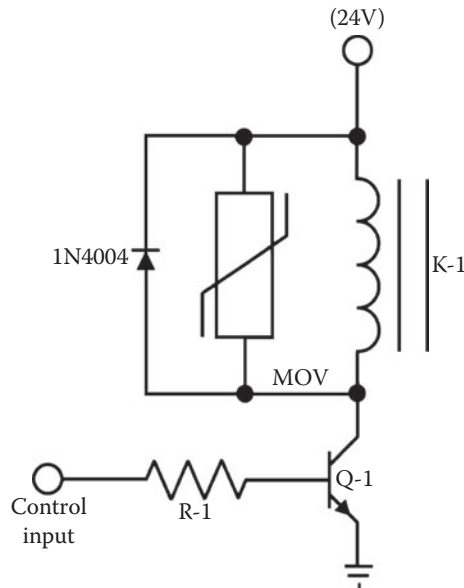


Figure 17.12 Transient suppression of a switched inductive load.

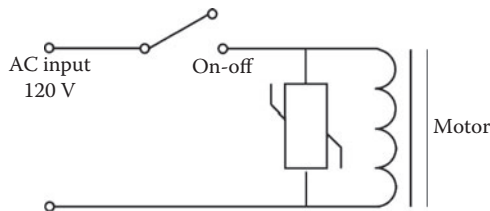


Figure 17.13 Transient suppression of switch arcing.

## 17.8 Bibliography

- Fardo, S., and D. Patrick, *Electrical Power Systems Technology*, Prentice-Hall, Englewood Cliffs, NJ, 1985.
- Fink, D., and D. Christiansen (Eds.), *Electronics Engineers' Handbook*, 3rd ed., McGraw-Hill, New York, 1989.
- McPartland, J., and B. McPartland, *National Electrical Code Handbook*, 20th ed., McGraw-Hill, New York, 1990.
- MOV Varistor Data and Applications Manual, General Electric Company, Auburn, NY, 1976.
- Schneider, J., "Surge Protection and Grounding Methods for AM Broadcast Transmitter Sites," *Proceedings of the SBE National Convention and Broadcast Engineering Conference*, Society of Broadcast Engineers, Indianapolis, IN, 1987.

## 18.1 Introduction

---

The attention given to the design and installation of a facility ground system is a key element in the day-to-day reliability of the plant. A well-designed and -installed ground network is invisible to the engineering staff. A marginal ground system, however, will cause problems on a regular basis. Grounding schemes can range from simple to complex, but any system serves three primary purposes:

- Provides for operator safety
- Protects electronic equipment from damage caused by transient disturbances
- Diverts stray radio frequency energy from sensitive audio, video, control, and computer equipment

Most engineers view grounding mainly as a method to protect equipment from damage or malfunction. However, the most important element is operator safety. The 120 or 208 Vac line current that powers most equipment can be dangerous — even deadly — if handled improperly. Grounding of equipment and structures provides protection against wiring errors or faults that could endanger human life.

Proper grounding is basic to protection against ac line disturbances. This applies whether the source of the disturbance is lightning, power-system switching activities, or faults in the distribution network. Proper grounding is also a key element in preventing radio frequency interference in transmission or computer equipment. A facility with a poor ground system can experience RFI problems on a regular basis. Implementing an effective ground network is not an easy task. It requires planning, quality components, and skilled installers. It is not inexpensive. However, proper grounding is an investment that will pay dividends for the life of the facility.

Any ground system consists of two key elements: (1) the earth-to-grounding electrode interface outside the facility, and (2) the ac power and signal-wiring systems inside the facility.

### 18.1.1 Terms and Codes

A *facility* can be defined as something that is built, installed, or established to serve a particular purpose [1]. A facility is usually thought of as a single building or group of buildings. The National Electrical Code (NEC) uses the term *premises* to refer to a facility when it defines premises wiring as the interior and exterior (facility) wiring, such as power, lighting, control, and signal systems. Premises wiring includes the service and all permanent and temporary wiring between the service and the load equipment. Premises wiring does not include wiring internal to any load equipment.

## 18.2 The Need for Grounding

---

The Institute of Electrical and Electronics Engineers (IEEE) defines *grounding* as a conducting connection, whether intentional or accidental, by which an electric circuit or equipment is connected to the earth or to some conducting body of relatively large extent that serves in place of the earth. It is used for establishing and maintaining the potential of the earth (or of the conducting body) or approximately that potential, on conductors connected to it, and for conducting ground current to and from the earth (or the conducting body) [2]. Based on this definition, the reasons for grounding can be identified as:

- Personnel safety by limiting potentials between all noncurrent-carrying metal parts of an electrical distribution system

- Personnel safety and control of electrostatic discharge (ESD) by limiting potentials between all noncurrent-carrying metal parts of an electrical distribution system and the Earth
- Fault isolation and equipment safety by providing a low-impedance fault return path to the power source to facilitate the operation of overcurrent devices during a ground fault

The IEEE definition makes an important distinction between *ground* and *earth*. *Earth* refers to mother earth, and *ground* refers to the equipment grounding system, which includes equipment grounding conductors, metallic raceways, cable armor, enclosures, cabinets, frames, building steel, and all other noncurrent-carrying metal parts of the electrical distribution system.

There are other reasons for grounding not implicit in the IEEE definition. Overvoltage control has long been a benefit of proper power-system grounding and is described in IEEE Standard 142, also known as the *Green Book* [3]. With the increasing use of electronic computer systems, noise control has become associated with the subject of grounding and is described in IEEE Standard 1100, the *Emerald Book*. [4].

### 18.2.1 Equipment Grounding

Personnel safety is achieved by interconnecting all noncurrent-carrying metal parts of an electrical distribution system and then connecting the interconnected metal parts to the earth [5]. This process of interconnecting metal parts is called *equipment grounding* and is illustrated in [Figure 18.1](#), where the equipment grounding conductor is used to interconnect the metal enclosures. Equipment grounding insures that there is no difference of potential, and thus no shock hazard, between noncurrent-carrying metal parts anywhere in the electrical distribution system. Connecting the equipment grounding system to earth insures that there is no difference of potential between the earth and the equipment grounding system. It also prevents static charge buildup.

### 18.2.2 System Grounding

System grounding, which is also illustrated in [Figure 18.1](#), is the process of intentionally connecting one of the current-carrying conductors of the electrical distribution system to ground [5]. The figure shows the neutral conductor intentionally connected to ground and the earth. This conductor is called the *grounded* conductor because it is intentionally grounded. The purpose of system grounding is overvoltage control and equipment safety through fault isolation. An ungrounded system is subject to serious overvoltages under conditions such as intermittent ground faults, resonant conditions, and contact with higher voltage systems. Fault isolation is achieved by providing a low-impedance return path from the load back to the source, which will ensure operation of overcurrent devices in the event of a ground fault. The system ground connection makes this possible by connecting the equipment grounding system to the low side of the voltage source. Methods of system grounding include solidly grounded, ungrounded, and impedance-grounded.

*Solidly grounded* means that an intentional zero-impedance connection is made between a current-carrying conductor and ground. The single-phase ( $1\phi$ ) system shown in [Figure 18.1](#) is solidly grounded. A solidly grounded, three-phase, four-wire, wye system is illustrated in [Figure 18.2](#). The neutral is connected directly to ground with no impedance installed in the neutral circuit. The NEC permits this connection to be made at the service entrance only [6]. The advantages of a solidly grounded wye system include reduced magnitude of transient overvoltages, improved fault protection, and faster location of ground faults. There is one disadvantage of the solidly grounded wye system. For low-level arcing ground faults, the application of sensitive, properly coordinated, ground-fault protection (GFP) devices is necessary to prevent equipment damage from arcing ground faults. The NEC requires arcing ground-fault protection at 480 Y/277 V services, and a maximum sensitivity limit of 1200 A is permitted. Severe damage is less frequent at the lower voltage 208 V systems, where the arc may be self-extinguishing.

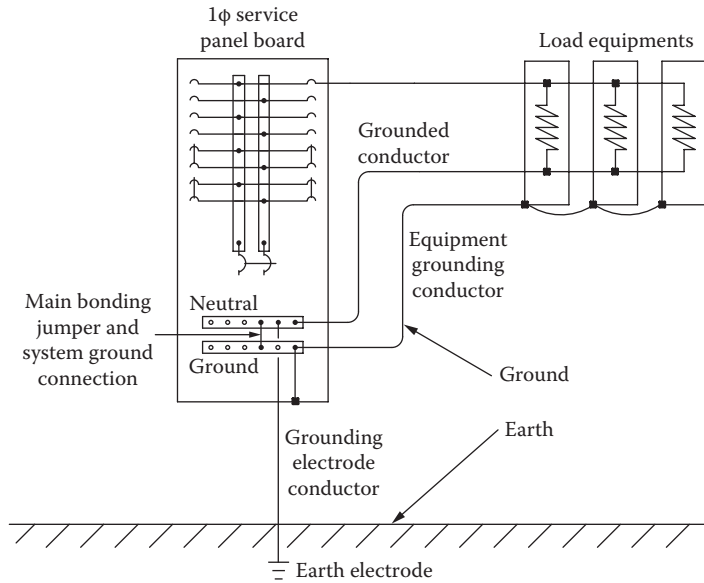


Figure 18.1 Equipment grounding and system grounding. (From [5]. Used with permission.)

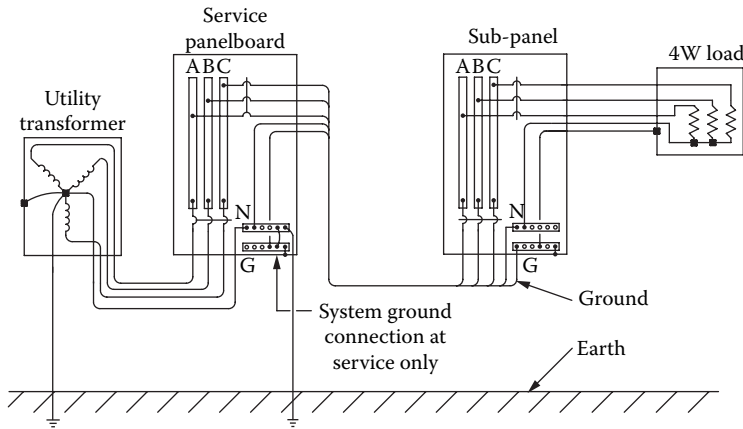


Figure 18.2 Solidly grounded wye power system. (From [5]. Used with permission.)

*Ungrounded* means that there is no intentional connection between a current-carrying conductor and ground. However, charging capacitance will create unintentional capacitive coupling from each phase to ground, making the system essentially a capacitance-grounded system. A three-phase, three-wire system from an ungrounded delta source is illustrated in Figure 18.3. The most important advantage of an ungrounded system is that an accidental ground fault in one phase does not require immediate removal of power. This allows for continuity of service, which made the ungrounded delta system popular in the past. However, ungrounded systems have serious disadvantages. Because there is no fixed system ground point, it is difficult to locate the first ground fault and to sense the magnitude of fault current. As a result, the fault is often permitted to remain on the system for an extended period of time. If a second fault should occur before the first one is removed, and the second fault is on a different phase, the result will be a double line-to-ground fault, causing serious arcing damage. Another problem with the ungrounded delta system is the occurrence of high transient overvoltages from phase-to-ground. Transient overvoltages can be caused by intermittent ground faults, with overvoltages capable of reaching a

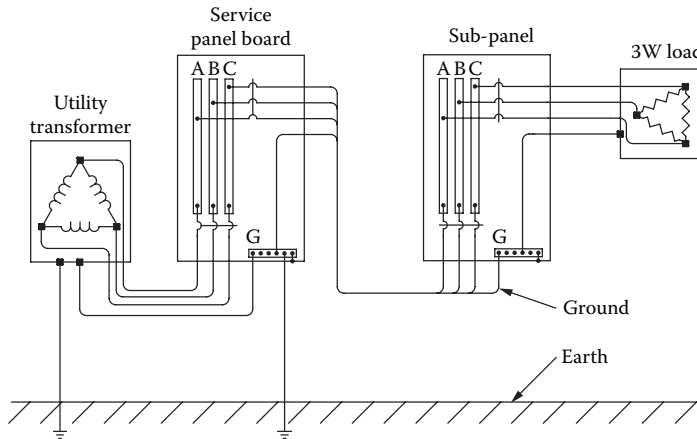


Figure 18.3 Ungrounded delta power system. (From [5]. Used with permission.)

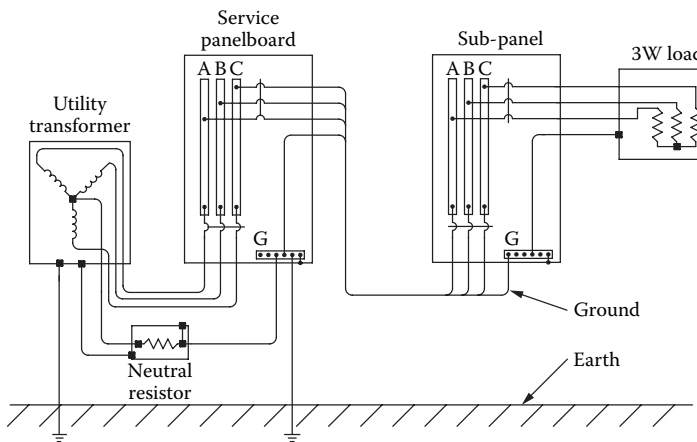


Figure 18.4 High-resistance grounded wye power system. (From [5]. Used with permission.)

phase-to-ground voltage of from six to eight times the phase-to-neutral voltage. Sustained overvoltages can ultimately result in insulation failure and thus moreground faults

*Impedance-grounded* means that an intentional impedance connection is made between a current-carrying conductor and ground. The high-resistance grounded wye system, illustrated in Figure 18.4, is an alternative to solidly grounded and ungrounded systems. High-resistance grounding will limit ground-fault current to a few amperes, thus removing the potential for arcing damage inherent in solidly grounded systems. The ground reference point is fixed, and relaying methods can locate first faults before damages from second faults occur. Internally generated transient overvoltages are reduced because the neutral-to-ground resistor dissipates any charge that may build up on the system-charging capacitances.

Table 18.1 compares the three most common methods of system grounding. There is no one best system grounding method for all applications. In choosing among the various options, the designer must consider the requirements for safety, continuity of service, and cost. Generally, low-voltage systems should be operated solidly grounded. For applications involving continuous processes in industrial plants or where shutdown might create a hazard, a high-resistance grounded wye system, or a solidly grounded wye system with an alternate power supply, may be used. The high-resistance grounded wye system combines many of the advantages of the ungrounded-delta system and the solidly grounded wye system. IEEE Standard 142 recommends that medium-voltage systems less than 15 kV be low-resistance

**Table 18.1** Comparison of System Grounding Methods (After [3].)

Characteristic Assuming No Fault Escalation	System Grounding Method		
	Solidly Grounded	Ungrounded	High Resistance
Operation of overcurrent device on first ground fault	Yes	No	No
Control of internally generated transient overvoltages	Yes	No	Yes
Control of steady-state overvoltages	Yes	No	Yes
Flash hazard	Yes	No	No
Equipment damage from arcing ground faults	Yes	No	No
Overvoltage (on unfaulted phases) from ground-fault <sup>1</sup>	L-N Voltage	>> L-L Voltage	L-L Voltage
Can serve line-to-neutral loads	Yes	No	No

<sup>1</sup> L = line, N = neutral.

grounded to limit ground fault damage yet permit sufficient current for detection and isolation of ground-faults. Standard 142 also recommends that medium-voltage systems over 15 kV be solidly grounded. Solid grounding should include sensitive ground-fault relaying in accordance with the NEC.

### 18.2.3 The Grounding Electrode

The process of connecting the grounding system to earth is called *earthing* and consists of immersing a metal electrode or system of electrodes into the earth [5]. The conductor that connects the grounding system to earth is called the *grounding electrode conductor*. The function of the grounding electrode conductor is to keep the entire grounding system at earth potential (i.e., voltage equalization during lightning and other transients) rather than for conducting ground-fault current. Therefore, the NEC allows reduced sizing requirements for the grounding electrode conductor when connected to *made* electrodes.

The basic measure of effectiveness of an earth electrode system is called *earth electrode resistance*. Earth electrode resistance is the resistance, in ohms, between the point of connection and a distant point on the earth called *remote earth*. Remote earth, about 25 ft from the driven electrode, is the point where earth electrode resistance does not increase appreciably when this distance is increased. Earth electrode resistance consists of the sum of the resistance of the metal electrode (negligible) plus the contact resistance between the electrode and the soil (negligible) plus the soil resistance itself. Thus, for all practical purposes, earth electrode resistance equals the soil resistance. The soil resistance is nonlinear, with most of the earth resistance contained within several feet of the electrode. Furthermore, current flows only through the electrolyte portion of the soil, not the soil itself. Thus, soil resistance varies as the electrolyte content (moisture and salts) of the soil varies. Without electrolyte, soil resistance would be infinite.

Soil resistance is a function of soil resistivity. A 1-cubic-meter sample of soil with a resistivity  $\rho$  of 1 ohm-meter will present a resistance  $R$  of 1 ohm between opposite faces. A broad variation of soil resistivity occurs as a function of soil types, and soil resistivity can be estimated or measured directly. Soil resistivity is usually measured by injecting a known current into a given volume of soil and measuring the resulting voltage drop. When soil resistivity is known, the earth electrode resistance of any given configuration (single rod, multiple rods, or ground ring) can be determined by using standard equations developed by Sunde [7], Schwarz [8], and others.

Earth resistance values should be as low as practicable, but are a function of the application. The NEC approves the use of a single made electrode if the earth resistance does not exceed 25  $\Omega$ . IEEE Standard 1100 reports that the very low earth resistance values specified for computer systems in the past are not necessary. Methods of reducing earth resistance values include the use of multiple electrodes in parallel, the use of ground rings, increased ground rod lengths, installation of ground rods to the permanent water level, increased area of coverage of ground rings, and the use of concrete-encased electrodes, ground wells, and electrolytic electrodes.



## 18.2.4 Earth Electrode

Earth electrodes may be made electrodes, *natural* electrodes, or *special-purpose* electrodes [5]. Made electrodes include driven rods, buried conductors, ground mats, buried plates, and ground rings. The electrode selected is a function of the type of soil and the available depth. Driven electrodes are used where bedrock is 10 ft or more below the surface. Mats or buried conductors are used for lesser depths. Buried plates are not widely used because of the higher cost when compared to rods. Ground rings employ equally spaced driven electrodes interconnected with buried conductors. Ground rings are used around large buildings, around small unit substations, and in areas having high soil resistivity.

Natural electrodes include buried water pipe electrodes and concrete-encased electrodes. The NEC lists underground metal water piping, available on the premises and not less than 10 ft in length, as part of a preferred grounding electrode system. Because the use of plastic pipe in new water systems will impair the effectiveness of water pipe electrodes, the NEC requires that metal underground water piping be supplemented by an additional approved electrode. Concrete below ground level is a good electrical conductor. Thus, metal electrodes encased in such concrete will function as excellent grounding electrodes. The application of concrete-encased electrodes is covered in IEEE Standard 142.

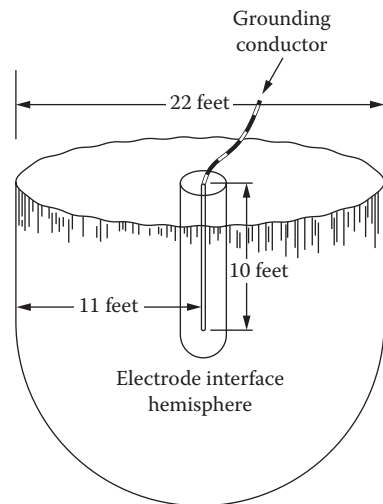
## 18.3 Establishing an Earth Ground

The grounding electrode is the primary element of any ground system. The electrode can take many forms. In all cases, its purpose is to interface the electrode (a conductor) with the earth (a semiconductor). Grounding principles have been refined to a science. Still, however, many misconceptions exist regarding grounding. An understanding of proper grounding procedures begins with the basic earth-interface mechanism.

### 18.3.1 Grounding Interface

The grounding electrode (or ground rod) interacts with the earth to create a hemisphere-shaped volume, as illustrated in Figure 18.5. The size of this volume is related to the size of the grounding electrode. The length of the electrode has a much greater effect than the diameter. Studies have demonstrated that the earth-to-electrode resistance from a driven ground rod increases exponentially with the distance from that rod. At a given point, the change becomes insignificant. It has been found that for maximum effectiveness of the earth-to-electrode interface, each ground rod requires a hemisphere-shaped volume with a diameter that is approximately 2.2 times the rod length [9].

The constraints of economics and available real estate place practical limitations on the installation of a ground system. It is important, however, to keep the 2.2 rule in mind because it allows the facility design engineer to use the available resources to the best advantage. Figure 18.6 illustrates the effects of locating ground rods too close (less than 2.2 times the rod length). An overlap area is created that effectively wastes some of the earth-to-electrode capabilities of the two ground rods. Research has shown, for example, that two 10-ft ground rods driven only 1 ft apart provide about the same resistivity as a single 10-ft rod.



**Figure 18.5** The effective earth-interface hemisphere resulting from a single driven ground rod. The 90% effective area of the rod extends to a radius of approximately 1.1 times the length of the rod. (After [10].)



There are three schools of thought with regard to ground-rod length. The first approach states that extending ground-rod length beyond about 10 ft is of little value for most types of soil. The reasoning behind this conclusion is presented in Figure 18.7a, where ground resistance is plotted as a function of ground-rod length. Beyond 10 ft in length, a point of diminishing returns is reached.

The second school of thought concludes that optimum earth-to-electrode interface is achieved with long (40 ft or greater) rods, driven to penetrate the local water table. When planning this type of installation, consider the difficulty that may be encountered when attempting to drive long ground rods. The foregoing discussion assumes that the soil around the grounding electrode is reasonably uniform in composition. Depending upon the location, however, this assumption may not hold true.

The third school of thought concludes that the optimum ground-rod installation is achieved by using the longest possible rod depth (length). Data to support this conclusion is given in Figure 18.7b, which plots ground-rod performance as a function of depth in soil of uniform resistivity. This curve does not take into account seasonal moisture content, changing chemical composition at different soil layers, and frozen soil conditions.

Given these three conflicting approaches, the benefits of hiring an experienced, licensed professional engineer to design the ground system can be readily appreciated.

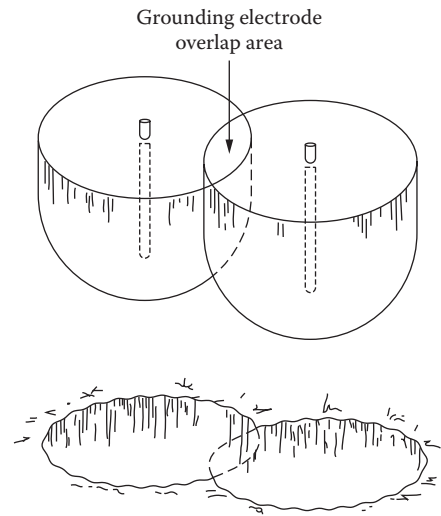
Horizontal grounding electrodes provide essentially the same resistivity as an equivalent-length vertical electrode, given uniform soil conditions. As Figure 18.8 demonstrates, the difference between a 10-ft vertical and a 10-ft horizontal ground rod is negligible (275 vs. 250  $\Omega$ ). This comparison includes the effects of the vertical connection element from the surface of the ground to the horizontal rod. Taken by itself, the horizontal ground rod provides an earth-interface resistivity of approximately 308  $\Omega$  when buried at a depth of 36 in.

Ground rods come in many sizes and lengths. The more popular sizes are 1/2, 5/8, 3/4, and 1 in. The 1/2-in. size is available in steel with stainless-clad, galvanized, or copper-clad rods. All-stainless-steel rods also are available. Ground rods can be purchased in unthreaded or threaded (sectional) lengths. The sectional sizes are typically 9/16- or 1/2-in. rolled threads. Couplers are made from the same materials as the rods. Couplers can be used to join 8- or 10-ft-length rods together. A 40-ft ground rod, for example, is driven one 10-ft section at a time.

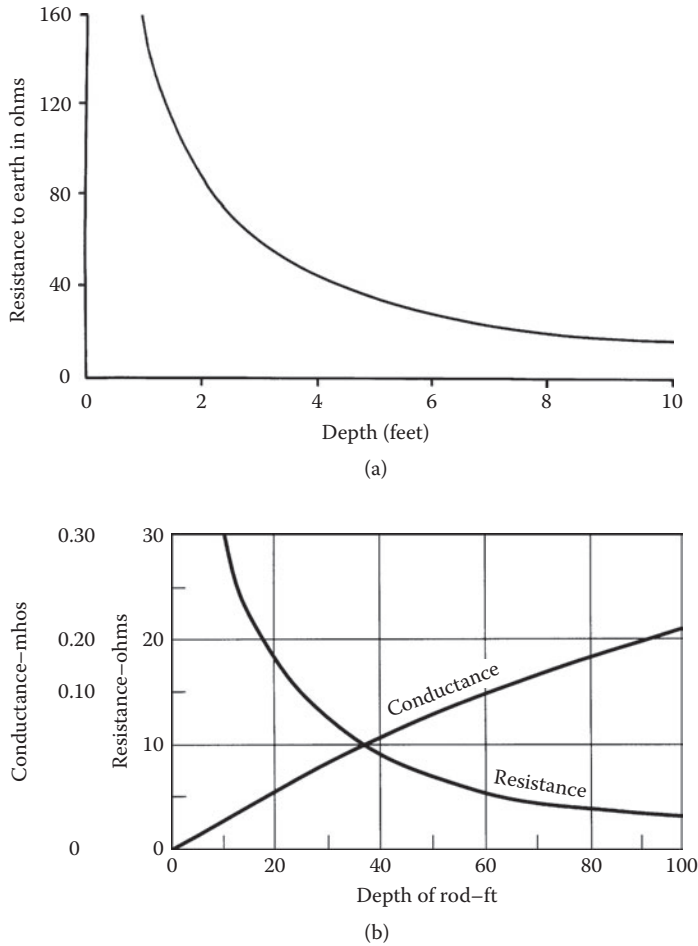
The type and size of ground rod used is determined by how many sections are to be connected and how hard or rocky the soil is. Copper-clad 5/8-in.  $\times$  10-ft rods are probably the most popular. Copper cladding is designed to prevent rust. The copper is not primarily to provide better conductivity. Although the copper certainly provides a better conductor interface to earth, the steel that it covers is also an excellent conductor when compared with ground conductivity. The thickness of the cladding is important only insofar as rust protection is concerned.

Wide variations in soil resistivity can be found within a given geographic area, as documented in Table 18.2. The wide range of values shown results from differences in moisture content, mineral content, and temperature.

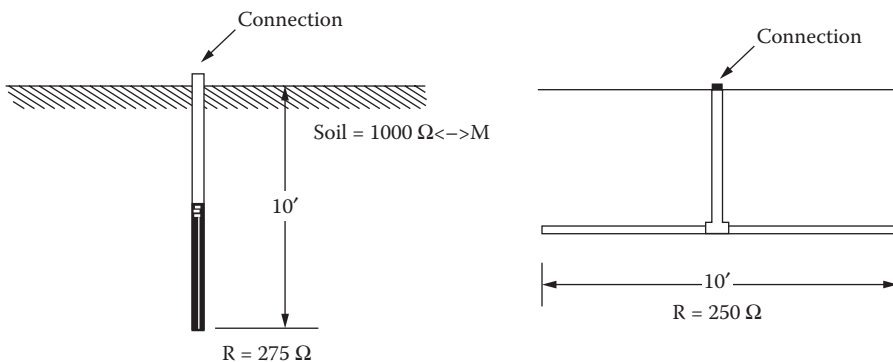
Temperature is a major concern in shallow grounding systems because it has a significant effect on soil resistivity [11]. During winter months, the ground system resistance can rise to unacceptable levels because of freezing of liquid water in the soil. The same shallow grounding system can also suffer from



**Figure 18.6** The effect of overlapping earth-interface hemispheres by placing two ground rods at a spacing less than 2.2 times the length of either rod. The overlap area represents wasted earth-to-grounding electrode interface capability. (After [10].)



**Figure 18.7** Charted grounding resistance as a function of ground-rod length: (a) data demonstrating that ground-rod length in excess of 10 ft produces diminishing returns (1-in.-diameter rod) [10], (b) data demonstrating that ground system performance continues to improve as depth increases. (Chart b from [12]. Used with permission.)



**Figure 18.8** The effectiveness of vertical ground rods compared with horizontal ground rods. (After [10].)

**Table 18.2** Typical Resistivity of Common Soil Types

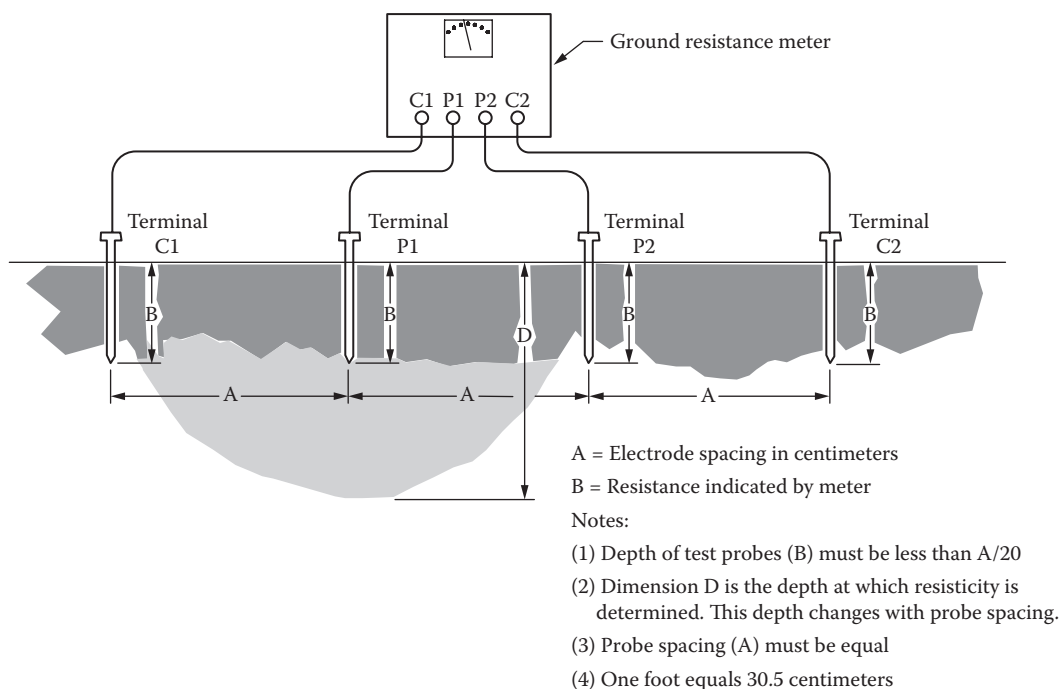
Type of Soil Resistivity in $\Omega/\text{cm}$	Average	Minimum	Maximum
Filled land, ashes, salt marsh	2,400	600	7,000
Top soils, loam	4,100	340	16,000
Hybrid soils	6,000	1,000	135,000
Sand and gravel	90,000	60,000	460,000

high resistance in the summer as moisture is evaporated from soil. It is advisable to determine the natural frost line and moisture profile for an area before attempting design of a ground system.

Figure 18.9 describes a four-point method for in-place measurement of soil resistivity. Four uniformly spaced probes are placed in a linear arrangement and connected to a ground resistance test meter. An alternating current (at a frequency other than 60 Hz) is passed between the two most distant probes, resulting in a potential difference between the center potential probes. The meter display in ohms of resistance can then be applied to determine the average soil resistivity in ohm-centimeters for the hemispherical area between the C1 and P2 probes.

Soil resistivity measurements should be repeated at a number of locations to establish a resistivity profile for the site. The depth of measurement can be controlled by varying the spacing between the probes. In no case should the probe length exceed 20% of the spacing between probes.

After the soil resistivity for a site is known, calculations can be made to determine the effectiveness of a variety of ground system configurations. Equations for several driven rod and radial cable configurations are given in Reference 11, which — after the solid resistivity is known — can be used for the purpose of estimating total system resistance. Generally, driven rod systems are appropriate where soil resistivity continues to improve with depth or where temperature extremes indicate seasonal frozen or dry soil conditions. Figure 18.10 shows a typical soil resistivity map for the U. S..



**Figure 18.9** The four-point method for soil resistivity measurement. (From [11]. Used with permission.)

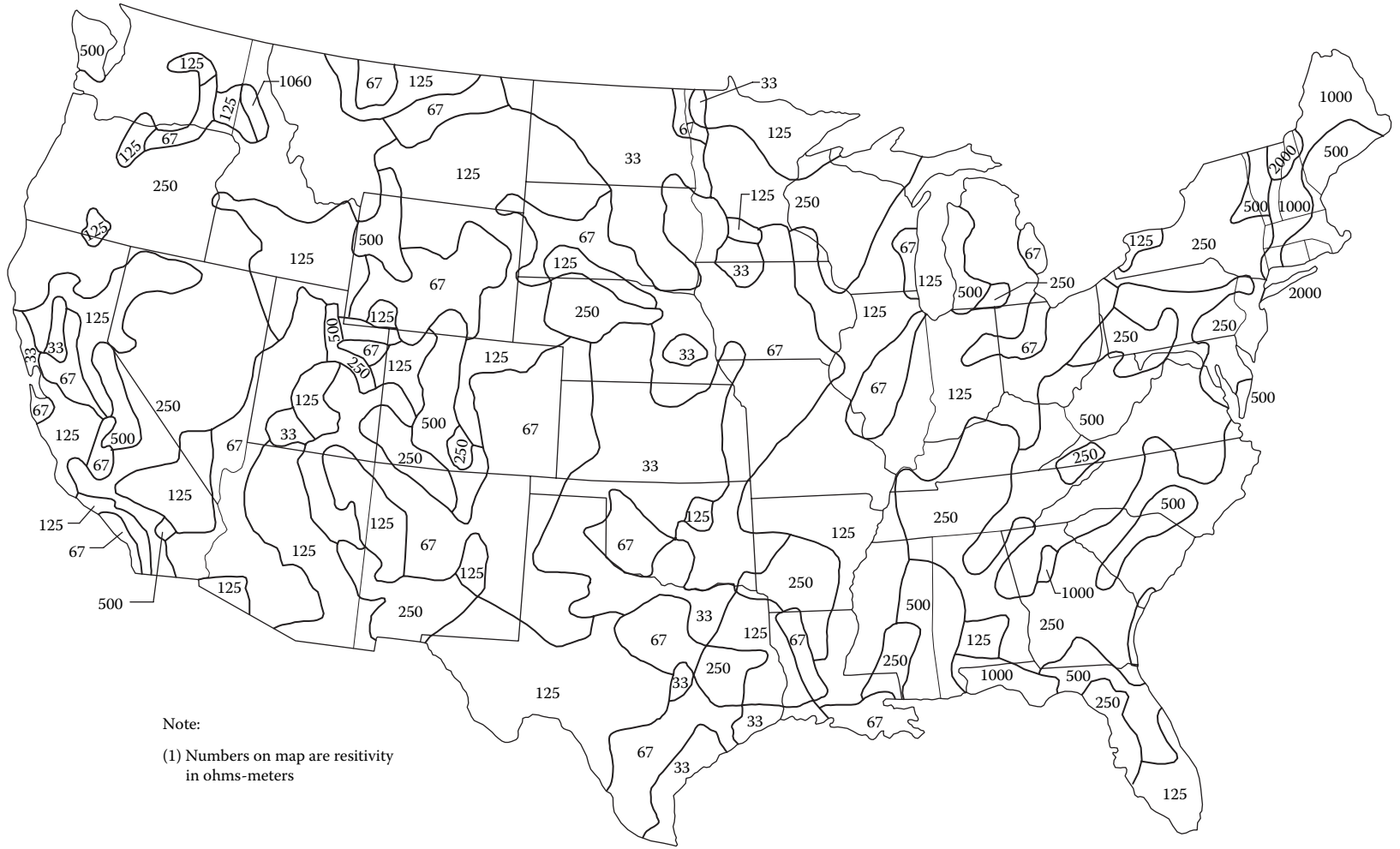


Figure 18.10 Typical soil resistivity map for the U.S. (From [11]. Used with permission.)

### 18.3.1.1 Ground Electrode Testing

Testing of all ground electrodes before they are connected to form a complex network is a fairly simple process that is well described in the documentation included with ground electrode meters. This instructional process, therefore, will not be described here. Also, the system as a whole should be tested after all interconnections are made, providing a benchmark for future tests.

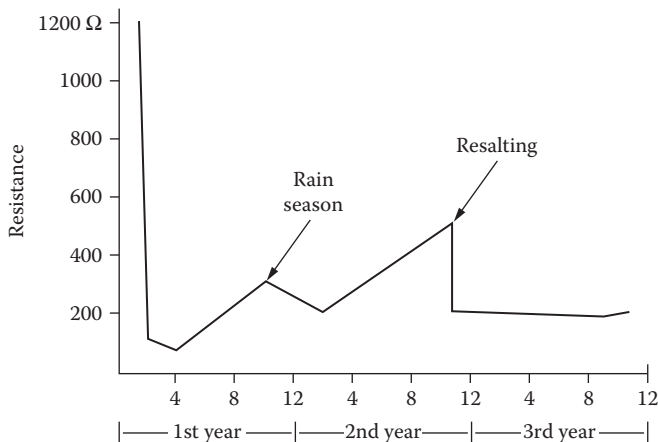
At a new site, it is often advisable to perform ground-system tests before the power company ground/neutral conductor is attached to the system. Conduct a before-and-after test with probes in the same position to determine the influence of the power company attachment [11]. It is also worthwhile to install permanent electrodes and marker monuments at the original probe positions to ensure the repeatability of future tests.

### 18.3.2 Chemical Ground Rods

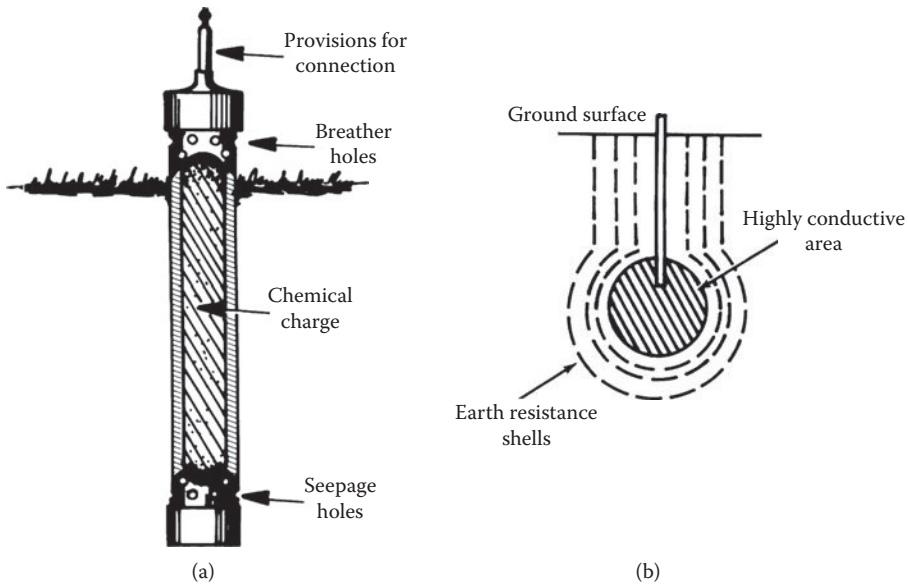
A chemically activated ground system is an alternative to the conventional ground rod. The idea behind the chemical ground rod is to increase the earth-to-electrode interface by conditioning the soil surrounding the rod. Experts have known for many years that the addition of ordinary table salt (NaCl) to soil will reduce the resistivity of the earth-to-ground electrode interface. With the proper soil moisture level (4 to 12%), *salting* can reduce soil resistivity from perhaps 10,000  $\Omega/m$  to less than 100  $\Omega/m$ . Salting the area surrounding a ground rod (or group of rods) follows a predictable life-cycle pattern, as illustrated in Figure 18.11. Subsequent salt applications are rarely as effective as the initial salting.

Various approaches have been tried over the years to solve this problem. One such product is shown in Figure 18.12. This chemically activated grounding electrode consists of a 2-1/2-in.-diameter copper pipe filled with rock salt. Breathing holes are provided on the top of the assembly, and seepage holes are located at the bottom. The theory of operation is simple. Moisture is absorbed from the air (when available) and is then absorbed by the salt. This creates a solution that seeps out of the base of the device and conditions the soil in the immediate vicinity of the rod.

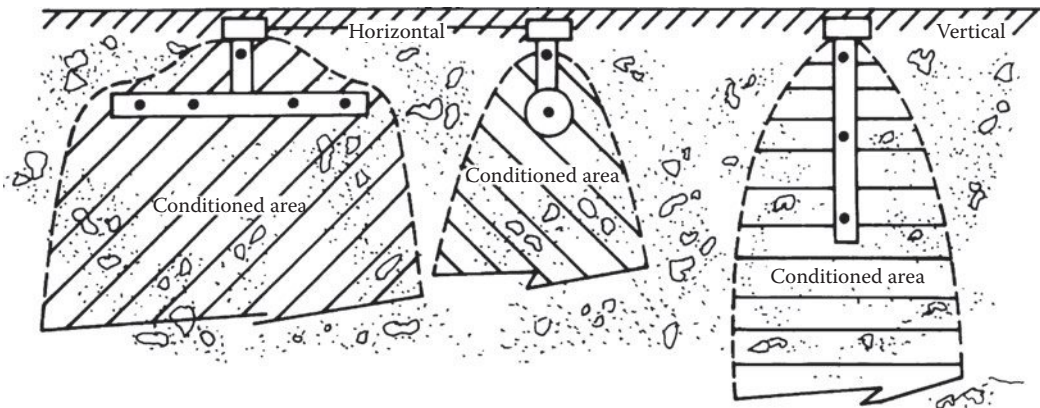
Another approach is shown in Figure 18.13. This device incorporates a number of ports (holes) in the assembly. Moisture from the soil (and rain) is absorbed through the ports. The metallic salts subsequently absorb the moisture, forming a saturated solution that seeps out of the ports and into the earth-to-electrode hemisphere. Tests have shown that if the moisture content is within the required range, earth resistivity can be reduced by as much as 100:1. Figure 18.14 shows the measured performance of a typical chemical ground rod in three types of soil.



**Figure 18.11** The effect of soil salting on ground-rod resistance with time. The expected resalting period, shown here as 2 years, varies depending on the local soil conditions and the amount of moisture present. (After [10].)



**Figure 18.12** An air-breathing chemically activated ground rod: (a) breather holes at the top of the device permit moisture penetration into the chemical charge section of the rod; (b) a salt solution seeps out of the bottom of the unit to form a conductive shell. (After [10].)



**Figure 18.13** Variations on the chemically activated ground rod. Multiple holes are provided on the ground-rod assembly to increase the effective earth-to-electrode interface. Note that chemical rods can be produced in a variety of configurations. (After [10].)

Implementations of chemical ground-rod systems vary depending on the application. Figure 18.15 illustrates a counterpoise ground consisting of multiple leaching apertures connected in a spoke fashion to a central hub. The system is serviceable in that additional salt compound can be added to the hub at required intervals to maintain the effectiveness of the ground. Figure 18.16 shows a counterpoise system made up of individual chemical ground rods interconnected with radial wires buried below the surface.

### 18.3.3 Ufer Ground System

Driving ground rods is not the only method of achieving a good earth-to-electrode interface [9]. The concept of the *Ufer* ground has gained interest because of its simplicity and effectiveness. The Ufer approach (named for its developer), however, must be designed into a new structure. It cannot be added

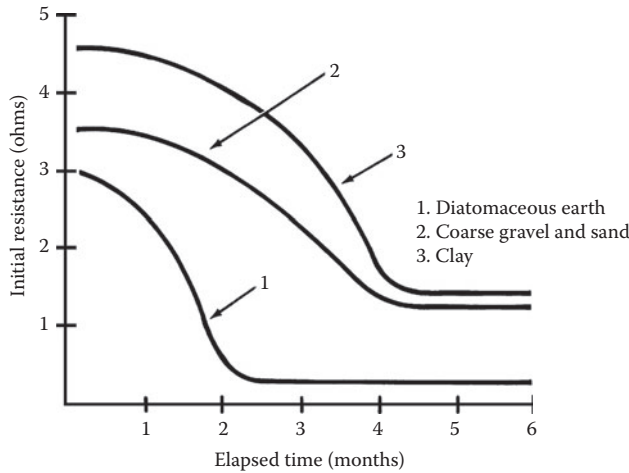


Figure 18.14 Measured performance of a chemical ground rod. (After [10].)

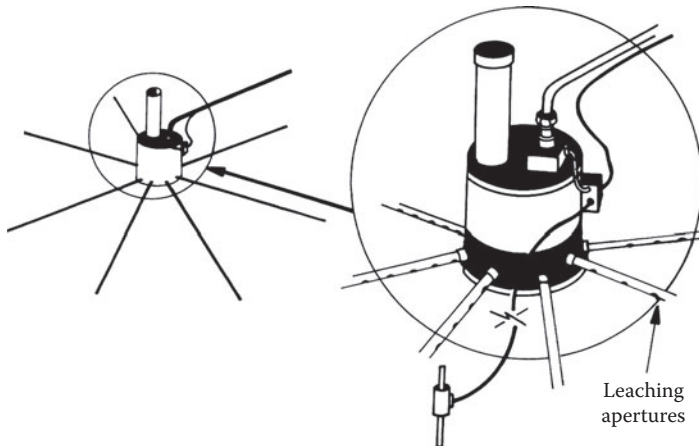


Figure 18.15 Hub-and-spoke counterpoise ground system. (After [10].)

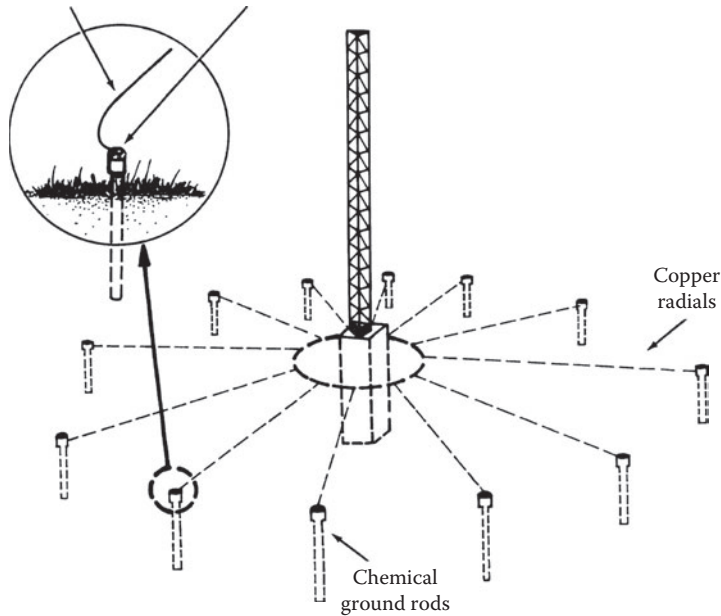
on later. The Ufer ground takes advantage of the natural chemical- and water-retention properties of concrete to provide an earth ground. Concrete typically retains moisture for 15 to 30 days after a rain. The material has a ready supply of ions to conduct current because of its moisture-retention properties, mineral content, and inherent pH. The large mass of any concrete foundation provides a good interface to ground.

A Ufer system, in its simplest form, is made by routing a solid-copper wire (no. 4 gauge or larger) within the foundation footing forms before concrete is poured. Figure 18.17 shows one such installation. The length of the conductor run within the concrete is important. Typically a 20-ft run (10 ft in each direction) provides a 5 Ω ground in 1000 Ω/m soil.

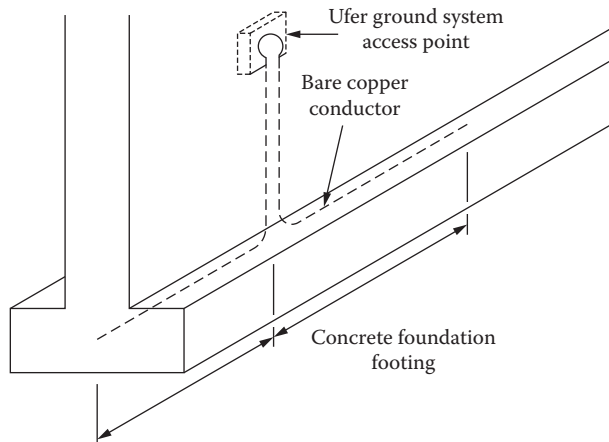
As an alternative, steel reinforcement bars (rebar) can be welded together to provide a rigid, conductive structure. A ground lug is provided to tie equipment to the ground system in the foundation. The rebar must be welded, not tied, together. If it is only tied, the resulting poor connections between rods can result in arcing during a current surge. This can lead to deterioration of the concrete in the affected areas.

The design of a Ufer ground is not to be taken lightly. Improper installation can result in a ground system that is subject to problems. The grounding electrodes must be kept a minimum of 3 in. from the bottom and sides of the concrete to avoid the possibility of foundation damage during a large lightning





**Figure 18.16** Tower grounding scheme using buried copper radials and chemical ground rods. (After [10].)



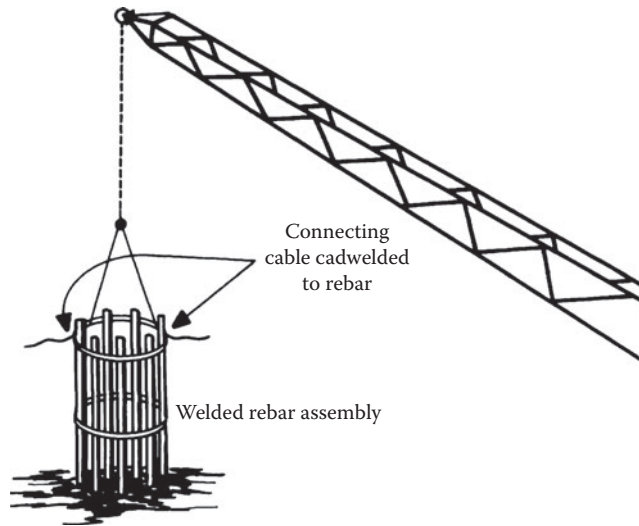
**Figure 18.17** The basic concept of a Ufer ground system, which relies on the moisture-retentive properties of concrete to provide a large earth-to-electrode interface. Design of such a system is critical. Do not attempt to build a Ufer ground without the assistance of an experienced contractor. (After [9].)

surge. If an electrode is placed too near the edge of the concrete, a surge could turn the water inside the concrete to steam and break the foundation apart.

The Ufer approach also can be applied to guy-anchor points or a tower base, as illustrated in [Figure 18.18](#). Welded rebar or ground rods sledged in place after the rebar cage is in position can be used. By protruding below the bottom concrete surface, the ground rods add to the overall electrode length to help avoid thermal effects that can crack the concrete. The maximum length necessary to avoid breaking the concrete under a lightning discharge is determined by the following:

- Type of concrete (density, resistivity, and other factors)
- Water content of the concrete
- How much of the buried concrete surface area is in contact with the ground





**Figure 18.18** The Ufer ground system as applied to a transmission-tower base or guy-wire anchor point. When using this type of ground system, bond all rebar securely to prevent arcing in the presence of large surge currents. (After [9].)

- Ground resistivity
- Groundwater content
- Size and length of the ground rod
- Size of lightning flash

The last variable is a bit of a gamble. The 50% mean occurrence of lightning strikes is 18 A, but superstrikes can occur that approach 100 to 200 kA.

Before implementing a Ufer ground system, consult a qualified contractor. Because the Ufer ground system will be the primary grounding element for the facility, it must be done correctly.

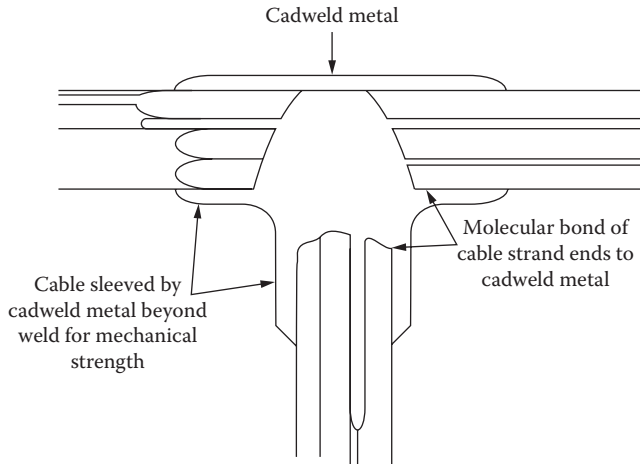
### 18.3.4 Bonding Ground-System Elements

A ground system is only as good as the methods used to interconnect the component parts [9]. Do not use soldered-only connections outside the equipment building. Crimped/brazed and *exothermic* (*Cadwelded*) connections are preferred. (Cadweld is a registered trademark of Erico Corp.) To make a proper bond, all metal surfaces must be cleaned, any finish removed to bare metal, and surface preparation compound applied. Protect all connections from moisture by appropriate means, usually sealing compound and heat-shrink tubing.

It is not uncommon for an untrained installer to use soft solder to connect the elements of a ground system. Such a system is doomed from the start. Soft-soldered connections cannot stand up to the acid and mechanical stress imposed by the soil. The most common method of connecting the components of a ground system is silver soldering. The process requires the use of brazing equipment, which may be unfamiliar to many facility engineers. The process uses a high-temperature/high-conductivity solder to complete the bonding process. For most grounding systems, however, the best approach to bonding is the exothermic process.

### 18.3.5 Exothermic Bonding

Exothermic bonding is the preferred method of connecting the elements of a ground system [9]. Molten copper is used to melt connections together, forming a permanent bond. This process is particularly useful in joining dissimilar metals. In fact, if copper and galvanized cable must be joined, exothermic bonding is the only acceptable means. The completed connection will not loosen or corrode and will carry as much current as the cable connected to it. Figure 18.19 illustrates the bonding that results from the exothermic process.

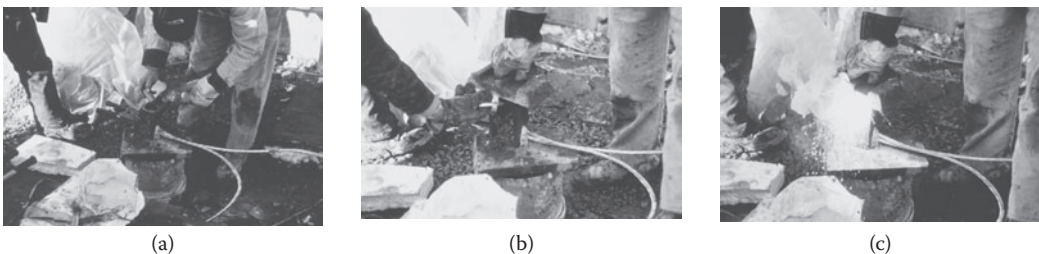


**Figure 18.19** The exothermic bonding process. (After [9].)

The bond is accomplished by dumping powdered metals (copper oxide and aluminum) from a container into a graphite crucible and igniting the material by means of a flint lighter. Reduction of the copper oxide by the aluminum produces molten copper and aluminum-oxide slag. The molten copper flows over the conductors, bonding them together. The process is illustrated in Figure 18.20. Figure 18.21 shows a typical mold. A variety of special-purpose molds are available to join different-size cables and copper strap. Figure 18.22 shows the bonding process for a copper-strap-to-ground-rod interface.

### 18.3.6 Ground-System Inductance

Conductors interconnecting sections or components of an earth ground system must be kept as short as possible to be effective [9]. The inductance of a conductor is a major factor in its characteristic impedance to surge energy. For example, consider a no. 6 AWG copper wire 10 m in length. The wire has a dc resistance of  $0.013 \Omega$  and an inductance of  $10 \mu\text{H}$ . For a 1000 A lightning surge with a  $1 \mu\text{s}$  rise time, the resistive voltage drop will be 13 V, but the reactive voltage drop will be 10 kV. Furthermore, any bends in the conductor will increase its inductance and further decrease the effectiveness of the wire. Bends in ground conductors should be gradual. A  $90^\circ$  bend is electrically equivalent to a 1/4-turn coil. The sharper the bend, the greater the inductance.



**Figure 18.20** Exothermic bonding is the preferred method of joining the elements of a ground system. This photo sequence illustrates the procedure: (a) the powdered copper oxide and aluminum compound are added to the mold after the conductors have been mechanically joined; (b) final preparation of the bond before igniting; (c) the chemical reaction that bonds the materials together.

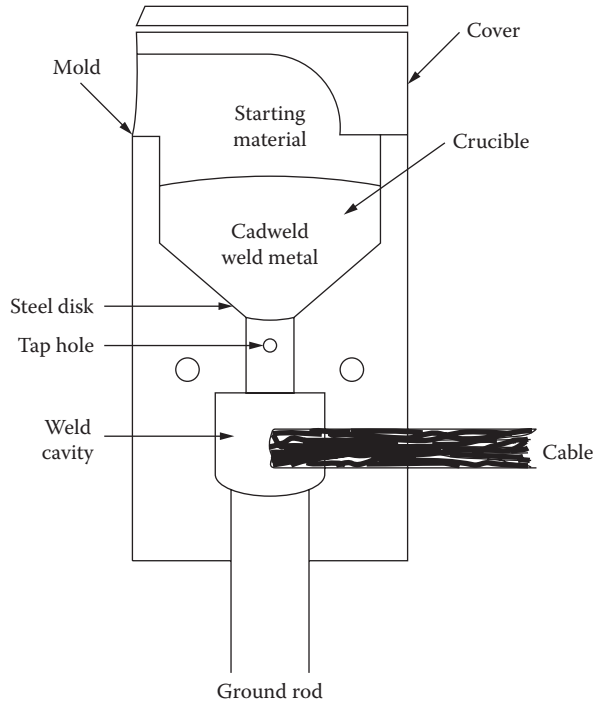


Figure 18.21 Typical exothermic bonding mold for connecting a cable to a ground rod. (After [9].)

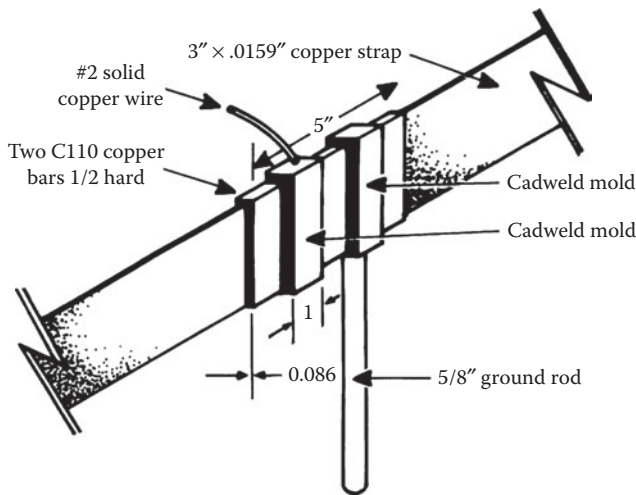


Figure 18.22 Cadweld mold for connecting a copper strap to a ground rod. (After [9].)

Because of the fast rise time of most lightning discharges and power-line transients, the *skin effect* plays an important role in ground-conductor selection. When planning a facility ground system, view the project from an RF standpoint.

The effective resistance offered by a conductor to radio frequencies is considerably higher than the ohmic resistance measured with direct currents. This is because of an action known as the skin effect,

which causes the currents to be concentrated in certain parts of the conductor and leaves the remainder of the cross section to contribute little or nothing toward carrying the applied current.

When a conductor carries an alternating current, a magnetic field is produced that surrounds the wire. This field continually is expanding and contracting as the ac current wave increases from zero to its maximum positive value and back to zero, then through its negative half-cycle. The changing magnetic lines of force cutting the conductor induce a voltage in the conductor in a direction that tends to retard the normal flow of current in the wire. This effect is more pronounced at the center of the conductor. Thus, current within the conductor tends to flow more easily toward the surface of the wire. The higher the frequency, or the faster the rise time of the applied waveform, the greater the tendency for current to flow at the surface. Figure 18.23 shows the distribution of current in a radial conductor.

When a circuit is operating at high frequencies, the skin effect causes the current to be redistributed over the conductor cross section in such a way as to make most of the current flow where it is encircled by the smallest number of flux lines. This general principle controls the distribution of current regardless of the shape of the conductor involved. With a flat-strip conductor, the current flows primarily along the edges, where it is surrounded by the smallest amount of flux

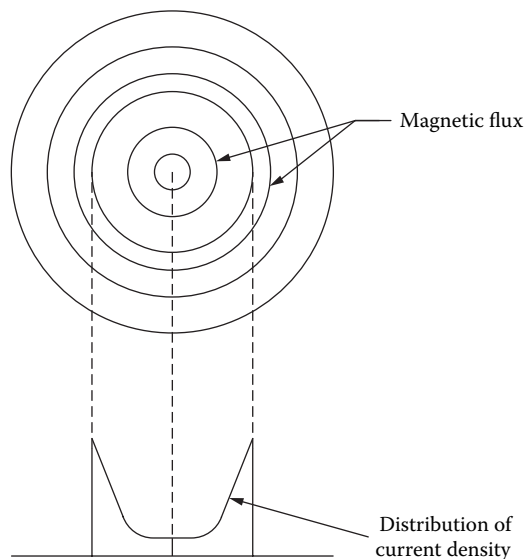


Figure 18.23 Skin effect on an isolated round conductor carrying a moderately high-frequency signal.

## 18.4 References

1. Webster's New Collegiate Dictionary.
2. IEEE Standard 100, *Definitions of Electrical and Electronic Terms*, IEEE, New York,.
3. IEEE Standard 142, "Recommended Practice for Grounding Industrial and Commercial Power Systems," IEEE, New York, 1982.
4. IEEE Standard 1100, "Recommended Practice for Powering and Grounding Sensitive Electronics Equipment," IEEE, New York, 1992.
5. DeWitt, W. E., "Facility Grounding Practices," in *The Electronics Handbook*, Jerry C. Whitaker (Ed.), CRC Press, Boca Raton, FL, pp. 2218–2228, 1996.
6. NFPA Standard 70, "The National Electrical Code," National Fire Protection Association, Quincy, MA, 1993.
7. Sunde, E. D., *Earth Conduction Effects in Transmission Systems*, Van Nostrand Co., New York, 1949.

8. Schwarz, S. J., "Analytical Expression for Resistance of Grounding Systems," *AIEE Transactions*, Vol. 73, Part III-B, pp. 1011–1016, 1954.
9. Block, R., "The Grounds for Lightning and EMP Protection," PolyPhaser Corporation, Gardnersville, NV, 1987.
10. Carpenter, R. B., "Improved Grounding Methods for Broadcasters," *Proceedings, SBE National Convention*, Society of Broadcast Engineers, Indianapolis, IN, 1987.
11. Lobnitz, E. A., "Lightning Protection for Tower Structures," in *NAB Engineering Handbook*, 9<sup>th</sup> ed., J. C. Whitaker (Ed.), National Association of Broadcasters, Washington, DC, 1998.
12. DeDad, J. A., (Ed.), "Basic Facility Requirements," in *Practical Guide to Power Distribution for Information Technology Equipment*, PRIMEDIA Intertec, Overland Park, KS, pp. 24, 1997.

## 18.5 Bibliography

---

- Benson, K. B., and J. C. Whitaker, *Television and Audio Handbook for Engineers and Technicians*, McGraw-Hill, New York, 1989.
- Block, R., "How to Ground Guy Anchors and Install Bulkhead Panels," *Mobile Radio Technology*, PRIMEDIA Intertec, Overland Park, KS, February 1986.
- Fardo, S., and D. Patrick, *Electrical Power Systems Technology*, Prentice-Hall, Englewood Cliffs, NJ, 1985.
- Hill, M., "Computer Power Protection," *Broadcast Engineering*, PRIMEDIA Intertec, Overland Park, KS, April 1987.
- Little, R., "Surge Tolerance: How Does Your Site Rate?" *Mobile Radio Technology*, Intertec Publishing, Overland Park, KS, June 1988.
- Mullinack, H. G., "Grounding for Safety and Performance," *Broadcast Engineering*, PRIMEDIA Intertec, Overland Park, KS, October 1986.
- Schneider, J., "Surge Protection and Grounding Methods for AM Broadcast Transmitter Sites," *Proceedings, SBE National Convention*, Society of Broadcast Engineers, Indianapolis, 1987.
- Technical Reports LEA-9-1, LEA-0-10, and LEA-1-8, Lightning Elimination Associates, Santa Fe Springs, CA.

# 19

## Grounding Tower Elements

---

### 19.1 Introduction

---

Guyed towers are better than self-supporting towers at dissipating lightning surge currents [1]. This is true, however, only if the guy anchors are grounded properly. Use of the Ufer technique is one way of effectively grounding the anchors. For anchors not provided with a Ufer ground during construction, other, more conventional techniques can be used. For guyed towers whose guy lines are not electrically continuous between the tower and the base, such as sectionalized towers (certain FM and TV broadcast towers and AM broadcast towers), surge current dissipation is essentially equivalent to a self-supporting tower.

Never rely on the turnbuckles of a guy anchor as a path for lightning energy. The current resulting from a large flash can weld the turnbuckles in position. If the turnbuckles are provided with a safety loop of guy cable (as they should be), the loop can be damaged where it contacts the guys and turnbuckle. [Figure 19.1](#) shows the preferred method of grounding guy wires: tie them together above the loop and turnbuckles. Do not make these connections with copper wire, even if they are Cadwelded. During periods of precipitation, water shed from the top copper wire will carry ions that may react with the lower galvanized (zinc) guy wires. This reaction washes off the zinc coating, allowing rust to develop.

The best way to make the connection is with all-galvanized materials. This includes the grounding wire, clamps, and ground rods. It may not be possible to use all galvanized materials because, at some point, a connection to copper conductors will be required. *Battery action* caused by the dissimilar metal junction may allow the zinc to act as a sacrificial anode. The zinc eventually will disappear into the soil, leaving a bare steel conductor that can fall victim to rust.

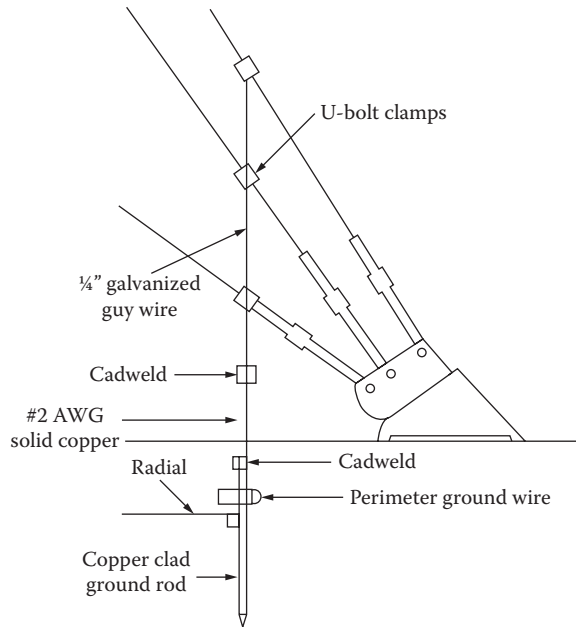
Ruling out an all-galvanized system, the next best scheme uses galvanized wire (guy-wire material) to tie the guy wires together. Just above the soil, Cadweld the galvanized wire to a copper conductor that penetrates below grade to the perimeter ground system. The height above grade for the connection is determined by the local snowfall or flood level. The electric conductivity of snow, although low, can cause battery action from the copper through the snow to the zinc. The Cadwelded joint should be positioned above the usual snow or flood level.

### 19.2 Ground-Wire Dressing

---

[Figure 19.2](#) illustrates the proper way to bond the tower base ground leads to the buried ground system [1]. Dress the leads close to the tower from the lowest practical structural element at the base. Keep the conductors as straight and short as possible. Avoid any sharp bends. Attach the ground wires to the tower only at one or more existing bolts (or holes). Do not drill any holes into the tower. Do not loosen any bolts to make the ground-wire attachment. Use at least two 3- to 4-in. copper straps between the base of the tower and the buried ground system. Position the straps next to the concrete pier of the tower base. For towers more than 200 ft in height, use four copper straps, one on each side of the pier.

[Figure 19.3](#) illustrates the proper way to bond guy wires to the buried ground system. The lead is dressed straight down from the topmost to the lowest guy. It should conform as close to vertical as possible and be dressed downward from the lower side of each guy wire after connecting to each wire ([Figure 19.1](#)). To ensure that no arcing will occur through the turnbuckle, a connection from the anchor plate to the perimeter ground circle is recommended. No. 2 gauge copper wire is recommended. This helps minimize



**Figure 19.1** Recommended guy-anchor grounding procedure. (After [1].)

the unavoidable inductance created by the conductor being in the air. Interconnect leads that are suspended in air must be dressed so that no bending radius is less than 8 in.

A *perimeter* ground — a circle of wire connected at several points to ground rods driven into the earth — should be installed around each guy-anchor point. The perimeter system provides a good ground for the anchor and, when tied together with the tower base radials, acts to rapidly dissipate lightning energy in the event of a flash. Tower base radials are buried wires interconnected with the tower base ground that extend away from the center point of the structure.

The required depth of the perimeter ground and the radials depends upon soil conductivity. Generally speaking, however, about 8 in. below grade is sufficient. In soil with good conductivity, the perimeter wire may be as small as no. 10 gauge. Because no. 2 gauge is required for the segment of conductor suspended in air, it may be easier to use no. 2 throughout. An added advantage is that the same size Cadweld molds may be used for all bonds.

### 19.3 Facility Ground Interconnection

Any radial that comes within 2 ft of a conductive structure must be tied into the ground system [1]. Bury the interconnecting wire, if possible, and approach the radial at a 45° angle, pointing toward the expected surge origin (usually the tower). Cadweld the conductor to the radial and to the structure.

For large-base, self-supporting towers, the radials should be split among each leg pad, as shown in Figure 19.4. The radials may be brought up out of the soil (in air) and each attached at spaced locations around the foot pad. Some radials may have to be tied together first and then joined to the foot pad. Remember, if space between the radial lines can be maintained, less mutual inductance (coupling) will exist, and the system surge impedance will be lower.

It is desirable to have a continuous one-piece ring with rods around the equipment building. Connect this ring to one, and only one, of the tower radials, thus forming no radial loops. (See Figure 19.5.) Bury the ring to the same depth as the radials to which it interconnects. Connect power-line neutral to the ring. *Warning:* Substantial current may flow when the power-line neutral is connected to the ring. Follow safety procedures when making this connection.



Install a ground rod (if the utility company has not installed one) immediately outside the generator or utility company vault, and connect this rod to the equipment building perimeter ground ring. Route a no. 1/0 insulated copper cable from the main power panel inside the generator vault to the ground rod outside the vault. Cut the cable to length, strip both ends, and tie one end to the power-line neutral at the main power panel in the generator vault. Connect the other end to the ground rod. *Warning:* Use care when making this connection. Hazardous voltage may exist between the power-line neutral and any point at earth potential.

Do not remove any existing earth ground connections to power-line neutral, particularly if they are installed by the power company. To do so may violate the local electrical code. The goal of this interconnection is to minimize noise that may be present on the neutral and to conduct this noise as directly as possible outside to earth ground.

### 19.3.1 Personnel Protection

The threat to personnel during a lightning strike ranges from the obvious danger of direct contact with a lightning strike to the more obscure effects of *step* and *touch voltages* [2]. Protection from a direct strike when near or within structures is accomplished with traditional rolling sphere concept methods. Step and touch potentials, however, are created as a lightning current passes through resistive soil and other available paths as it dissipates into the earth. A person in contact with only one point of the gradient will simply rise and fall in potential with the gradient without injury. A person in contact with multiple points on the earth or objects at different potentials along the gradient, however, will become part of the current path and may sustain injury or death.

Figure 19.6 [3, 4] indicates a number of methods for protecting personnel from the direct and secondary effects of lightning. A typical tower/transmitter site is used as an example. A technician responding to a service problem during a thunderstorm would likely exit his or her vehicle outside the gate, unlock and open the gate, and move the vehicle into the inside yard. The technician would then leave the vehicle and enter the building.

The threat of a direct lightning strike to the technician has been minimized by establishing a protective zone over the areas to be traversed. This zone is created by the tower and air terminals mounted atop light poles.

Step potentials are minimized through the use of a ground mat buried just below the surface of the area where the technician is expected to be outside the vehicle. Ground mats are commercially available, fabricated in a 6-in. × 6-in. square pattern using no. 8 AWG bare copper wire. Each intersection is welded, creating — for all practical purposes — an *equipotential area* that minimizes the step potential gradient in the area above the mat. The mat, as a whole, will rise and fall in potential as a result of the lightning

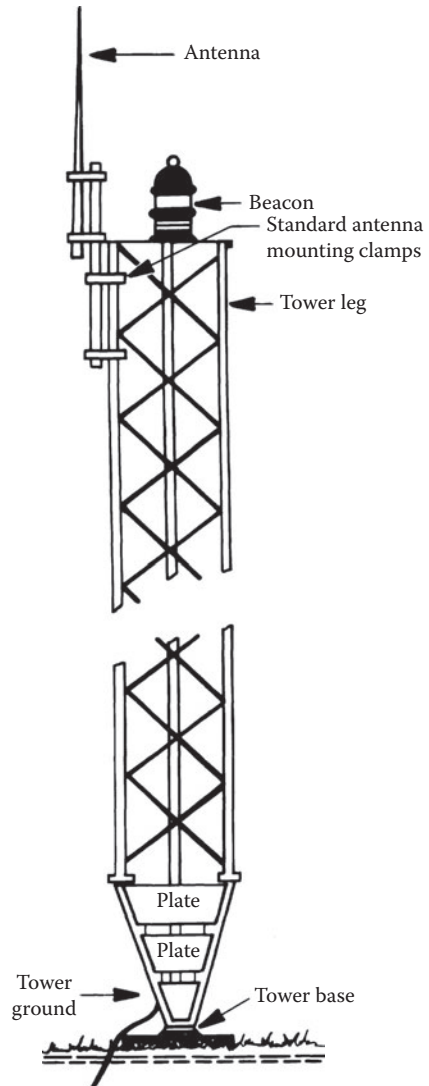
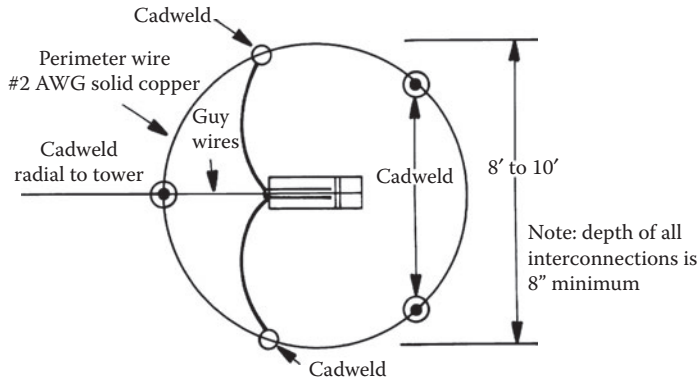
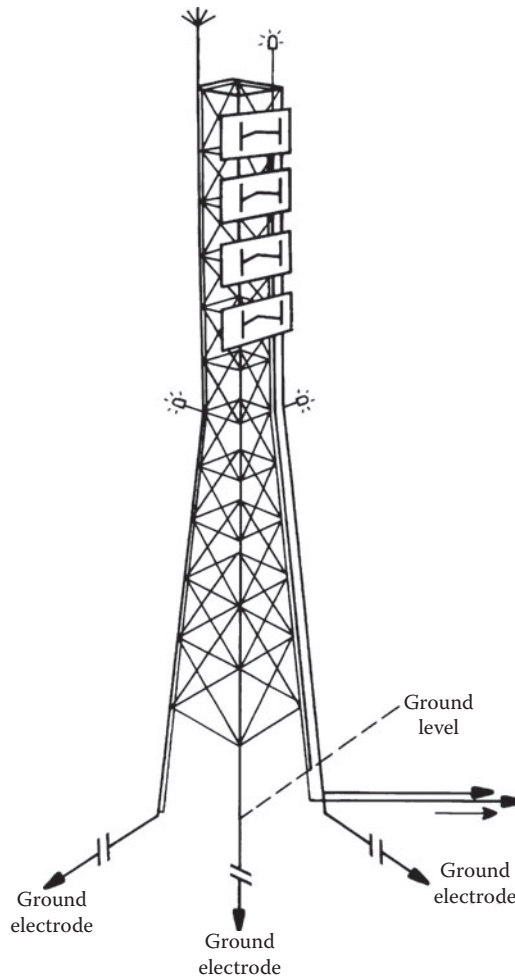


Figure 19.2 Ground-conductor dressing for the base of a guyed tower. (After [1].)





**Figure 19.3** Top view of proper guy-anchor grounding techniques. A properly dressed and installed ground wire prevents surge currents from welding turnbuckles and damaging safety loops. The perimeter ground connects to the tower base by way of a radial wire. (After [1].)



**Figure 19.4** Interconnecting a self-supporting tower to the buried ground system.

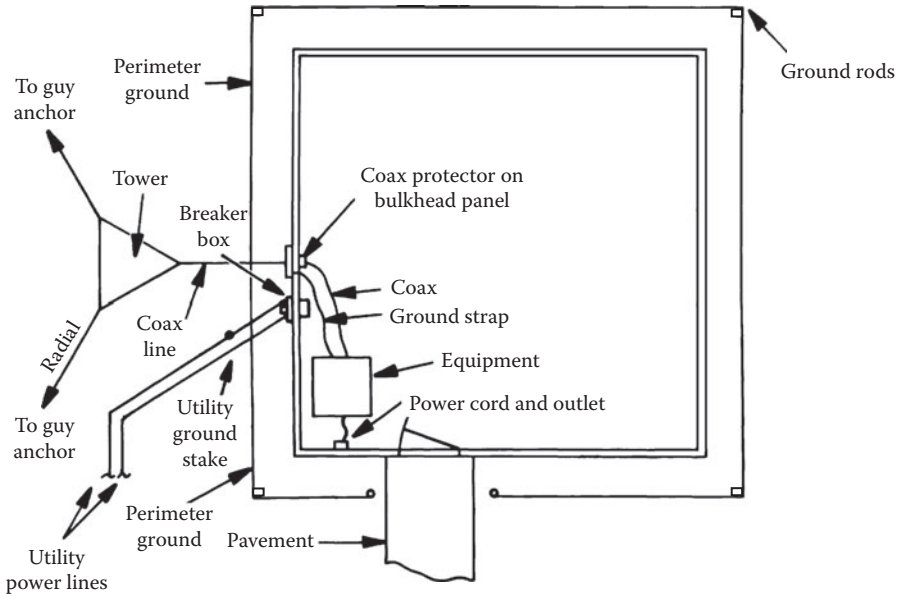


Figure 19.5 Interconnecting the metal structures of a facility to the ground system. (After [1].)

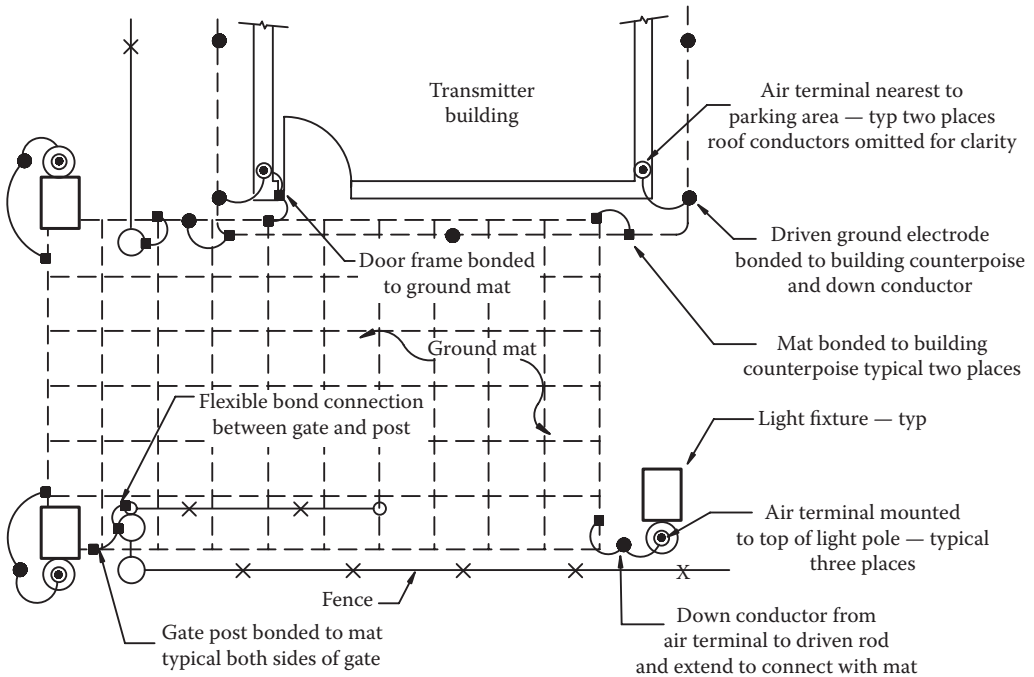


Figure 19.6 Protection methods for personnel at an exposed site. (From [2]. Used with permission.)

current discharges; however, there will be very little difference in potential between the technician's feet. Mats should be covered with 6 in. of crushed stone or pavement.

The threat of dangerous touch potentials is minimized by bonding the following elements to the ground system:

- Personnel ground mat
- Fence at each side of the gate opening
- Door frame of the transmitter building
- Flexible bonding connection between the swing gate and its terminal post

Such bonding will ensure that the object being touched by the technician is at or near the same potential as his or her feet.

Bonding both sides of the gate opening to the mat helps to ensure that the technician and both sides of the gate are at approximately the same potential while the gate is being handled. The flexible bond between the gate and its support post can be accomplished using a commercially available kit or by Cad-welding a short length of flexible no. 2/0 AWG welding cable between the two elements.

## 19.4 Grounding on Bare Rock

A bare rock mountaintop location provides special challenges to the facility design engineer [1]. There is no soil, thus there are no ground rods. Radials are the only means to develop a ground system. Install a large number of radials, laid straight, but not too taut. The portions not in contact with the rock are in air and form an inductance that will choke the surge current. Because rock is not conductive when it is dry, keep the radials short. Only a test measurement will determine how short the radials should be. A conventional earth-resistance tester will tell only half the story (besides, ground rods cannot be placed in rock for such a measurement). A dynamic ground tester offers the only way to obtain the true surge impedance of the system.

### 19.4.1 Rock-Based Radial Elements

On bare rock, a radial counterpoise will conduct and spread the surge charge over a large area. In essence, it forms a leaky capacitor with the more conductive earth on or under the mountain [1]. The conductivity of the rock will be poor when dry, but quite good when wet. If the site experiences significant rainfall before a lightning flash, protection will be enhanced. The worst case, however, must be assumed: an early strike under dry conditions.

The surge impedance, measured by a dynamic ground tester, should be 25  $\Omega$  or less. This upper-limit number is chosen so that less stress will be placed on the equipment and its surge protectors. With an 18 kA strike to a 25  $\Omega$  ground system, the entire system will rise 450 kV above the rest of the world at peak current. This voltage has the potential to jump almost 15.75 in. (0.35 in./10 kV at standard atmospheric conditions of 25°C, 30 in. of mercury and 50% relative humidity).

For nonsoil conditions, tower anchor points should have their own radial systems or be encapsulated in concrete. Configure the encapsulation to provide at least 3 in. of concrete on all sides around the embedded conductor. The length will depend on the size of the embedded conductor. Rebar should extend as far as possible into the concrete. The dynamic ground impedance measurements of the anchor grounds should each be less than 25  $\Omega$ .

The size of the bare conductor for each tower radial (or for an interconnecting wire) will vary, depending on soil conditions. On rock, a bare no. 1/0 or larger wire is recommended. Flat, solid-copper strap would be better, but may be blown or ripped if not covered with soil. If some amount of soil is available, no. 6 cable should be sufficient. Make the interconnecting radial wires continuous, and bury them as deep as possible; however, the first 6 to 10 in. will have the most benefit. Going below 18 in. will not be cost-effective, unless in a dry, sandy soil where the water table can be reached and ground-rod penetration is shallow. If only a small amount of soil exists, use it to cover the radials to the extent possible. It is

more important to cover radials in the area near the tower than at greater distances. If, however, soil exists only at the outer distances and cannot be transported to the inner locations, use the soil to cover the outer portions of the radials.

If soil is present, install ground rods along the radial lengths. Spacing between ground rods is affected by the depth that each rod is driven; the shallower the rod, the closer the allowed spacing. Because the ultimate depth a rod can be driven cannot always be predicted by the first rod driven, use a maximum spacing of 15 ft when selecting a location for each additional rod. Drive rods at building corners first (within 24 in. but not closer than 6 in. to a concrete footer unless that footer has an encapsulated Ufer ground), then fill in the space between the corners with additional rods.

Drive the ground rods in place; do not auger; set in place, then back-fill. The soil compactness is never as great on augured-hole rods when compared with driven rods. The only exception is when a hole is augured or blasted for a ground rod or rebar and then back-filled in concrete. Because concrete contains lime (alkali base) and is porous, it absorbs moisture readily, giving it up slowly. Electron carriers are almost always present, making the substance a good conductor.

If a Ufer ground is not being implemented, the radials may be Cadwelded to a subterranean ring, with the ring interconnected to the tower foot pad via a minimum of three no. 1/0 wires spaced at 120° angles and Cadwelded to the radial ring.

## 19.5 Transmission-System Grounding

---

Nature can devastate a communications site. Lightning can seriously damage an unprotected facility with little or no warning, leaving an expensive and time-consuming repair job. The first line of defense is proper grounding of the communications system.

### 19.5.1 Transmission Line

All coax and waveguide lines must include grounding kits for bonding the transmission line at the antenna [1]. On conductive structures, this can be accomplished by bonding the tail of the grounding kit to the structure itself. Remove all nonconductive paint and corrosion before attachment. Do not drill holes, and do not loosen any existing tower member bolts. Antenna clamping hardware can be used, or an all-stainless-steel hose clamp of the appropriate size can be substituted. The location of the tower-top ground is not as critical as the bottom grounding kit.

On nonconductive structures, a no. 1/0 or larger wire must be run down the tower [1]. Bond the transmission-line grounding kit to this down-run. Keep the wire as far away from all other conductive runs (aviation lights, coax, and waveguide) as possible. Separation of 2 ft is preferred; 18 in. is the minimum. If any other ground lines, conduit, or grounded metallic-structure members must be traversed that are closer than 18 in., they too must be grounded to the down-lead ground line to prevent flashover.

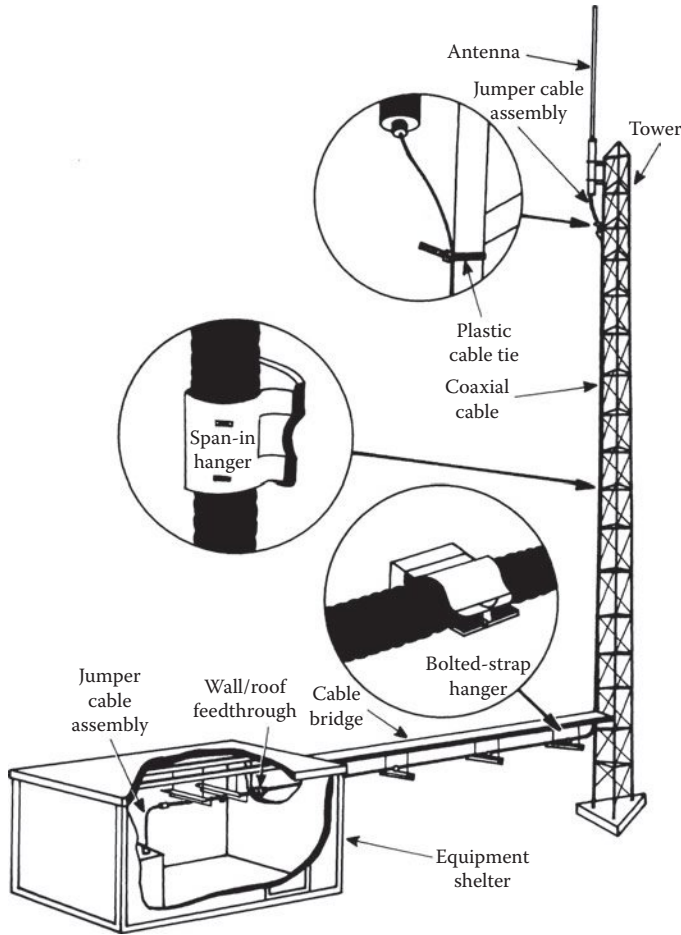
At the point where the coax or waveguide separates from the conductive structure (metal tower), a coax or waveguide grounding kit must be installed. Secure the connection to a large vertical structure member with a small number of joints. Attach to a structural member as low as possible on the tower.

Dress the grounding kit tails in a nearly straight 45° downward angle to the tower member. On nonconductive structures, a metal busbar must be used. Ground the bar to one or more of the vertical down-conductors and as close to ground level as possible.

Coaxial cables, lighting conduit, and other lines on the tower must be secured properly to the structure. [Figure 19.7](#) illustrates several common attachment methods.

### 19.5.2 Cable Considerations

Ground-strap connections must withstand weathering and maintain low electrical resistance between the grounded component and earth [1]. Corrosion impairs ground-strap performance. Braided-wire ground straps should not be used in outside installations. Through capillary action resembling that of a wick, the braid conveys water, which accelerates corrosion. Eventually, advancing corrosion erodes



**Figure 19.7** Transmission-line mounting and grounding procedures for a communications site.

the ground-strap cable. Braid also can act as a duct that concentrates water at the bond point. This water speeds corrosion, which increases the electrical resistance of the bond. A jacketed, seven-strand copper wire strap (no. 6 to no. 2) is recommended for transmission-line grounding at the tower.

### 19.5.3 Satellite Antenna Grounding

Most satellite receiving/transmitting antenna piers are encapsulated in concrete [1]. Consideration should be given, therefore, to implementing a Ufer ground for the satellite dish. A 4-in.-diameter pipe, submerged 4 to 5 ft in an 18-in.-diameter (augered) hole, will provide a good start for a Ufer-based ground system. It should be noted that an augered hole is preferred because digging and repacking the soil around the pier will create higher ground resistance. In areas of good soil conductivity ( $100 \Omega/\text{m}$  or less), this basic Ufer system may be adequate for the antenna ground.

**Figure 19.8** shows the preferred method: a hybrid Ufer/ground-rod and radial system. A cable connects the mounting pipe (Ufer ground) to a separate driven ground rod. The cable then is connected to the facility ground system. In areas of poor soil conductivity, additional ground rods are driven at increments (2.2 times the rod length) between the satellite dish and the facility ground system. Run all cables underground for best performance. Make the interconnecting copper wire no. 10 size or larger; bury the wire at least 8 in. below finished grade. **Figure 19.9** shows the addition of a lightning rod to the satellite dish.

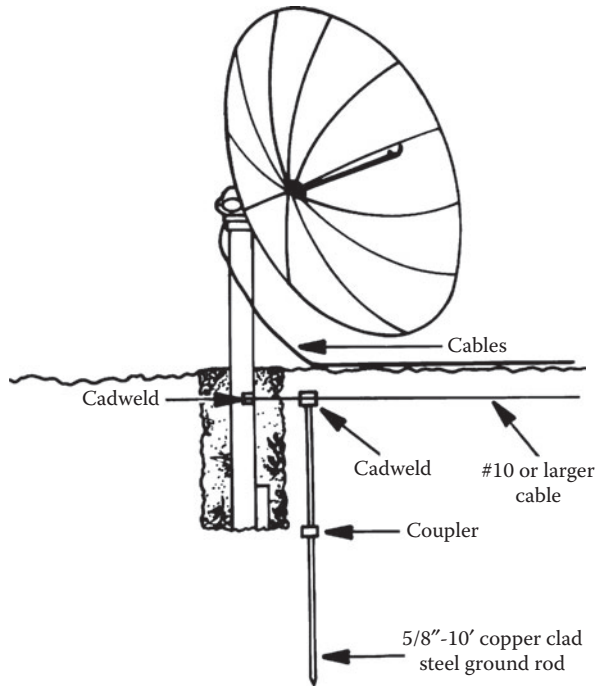


Figure 19.8 Grounding a satellite receiving antenna. (After [1].)

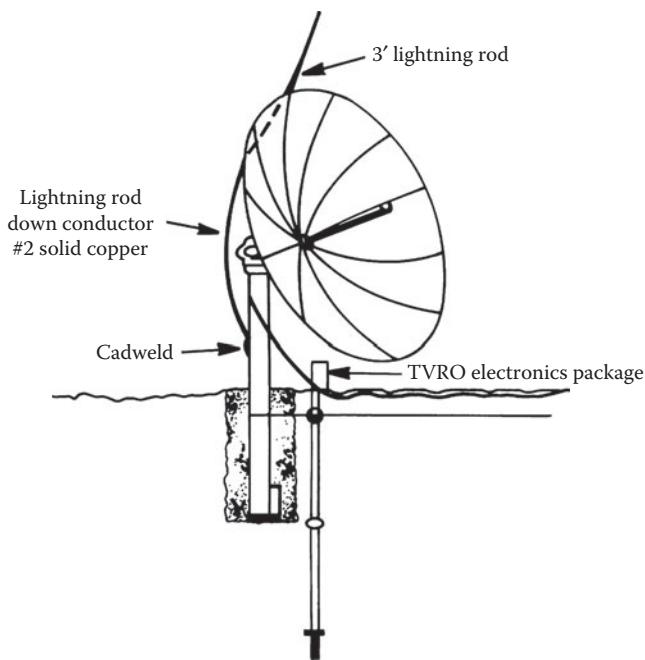


Figure 19.9 Addition of a lightning rod to a satellite antenna ground system. (After [9].)

## 19.6 References

---

1. Block, R., "The Grounds for Lightning and EMP Protection," PolyPhaser Corporation, Gardnerville, NV, 1987.
2. Lobnitz, E. A., "Lightning Protection for Tower Structures," in *NAB Engineering Handbook*, 9<sup>th</sup> ed., J. C. Whitaker (Ed.), National Association of Broadcasters, Washington, DC, 1998.
3. Military Handbook 419A, "Grounding, Bonding, and Shielding for Electronic Systems," U.S. Government Printing Office, Philadelphia, PA, December 1987.
4. IEEE 142 (Green Book), "Grounding Practices for Electrical Systems," IEEE, New York.

# 20

## Facility Ground-System Design

---

### 20.1 Introduction

---

After the required grounding elements have been determined, they must be connected into a unified system [1]. Many different approaches can be taken, but the goal is the same: establish a low-resistance, low-inductance path to surge energy. [Figure 20.1](#) shows a building ground system using a combination of ground rods and buried bare-copper radial wires. This design is appropriate when the building is large or located in an urban area. This approach also can be used when the facility is located in a high-rise building that requires a separate ground system. Most newer office buildings have ground systems designed into them. If a comprehensive building ground system is provided, use it. For older structures (constructed of wood or brick), a separate ground system will be needed.

[Figure 20.2](#) shows another approach in which a perimeter ground strap is buried around the building and ground rods are driven into the earth at regular intervals (2.2 times the rod length). The ground ring consists of a one-piece copper conductor that is bonded to each ground rod.

If a transmission or microwave tower is located at the site, connect the tower ground system to the main ground point via a copper strap. The width of the strap must be at least 1% of the length and, in any event, not less than 3 in. wide. The building ground system is not a substitute for a tower ground system, no matter what the size of the tower. The two systems are treated as independent elements, except for the point at which they interconnect.

Connect the utility company power-system ground rod to the main facility ground point as required by the local electrical code. Do not consider the building ground system to be a substitute for the utility company ground rod. The utility rod is important for safety reasons and must not be disconnected or moved. Do not remove any existing earth ground connections to the power-line neutral connection. To do so may violate local electrical code.

Bury all elements of the ground system to reduce the inductance of the overall network. Do not make sharp turns or bends in the interconnecting wires. Straight, direct wiring practices will reduce the overall inductance of the system and increase its effectiveness in shunting fast-rise-time surges to earth. [Figure 20.3](#) illustrates the interconnection of a tower and building ground system. In most areas, soil conductivity is high enough to permit rods to be connected with no. 6 or larger bare-copper wire. In areas of sandy soil, use copper strap. A wire buried in low-conductivity, sandy soil tends to be inductive and less effective in dealing with fast-rise-time current surges. As stated previously, make the width of the ground strap at least 1% of its overall length. Connect buried elements of the system as shown in [Figure 20.4](#).

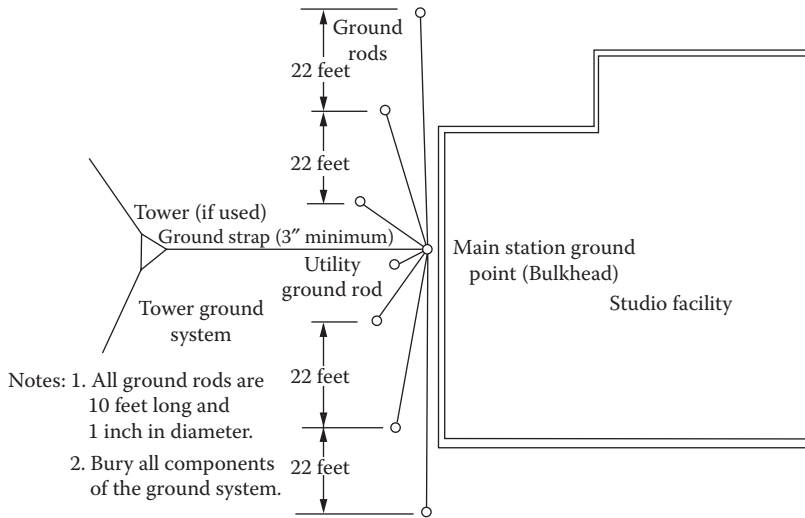
For small installations with a low physical profile, a simplified grounding system can be implemented, as shown in [Figure 20.5](#). A grounding plate is buried below grade level, and a ground wire ties the plate to the microwave tower mounted on the building.

### 20.2 Bulkhead Grounding

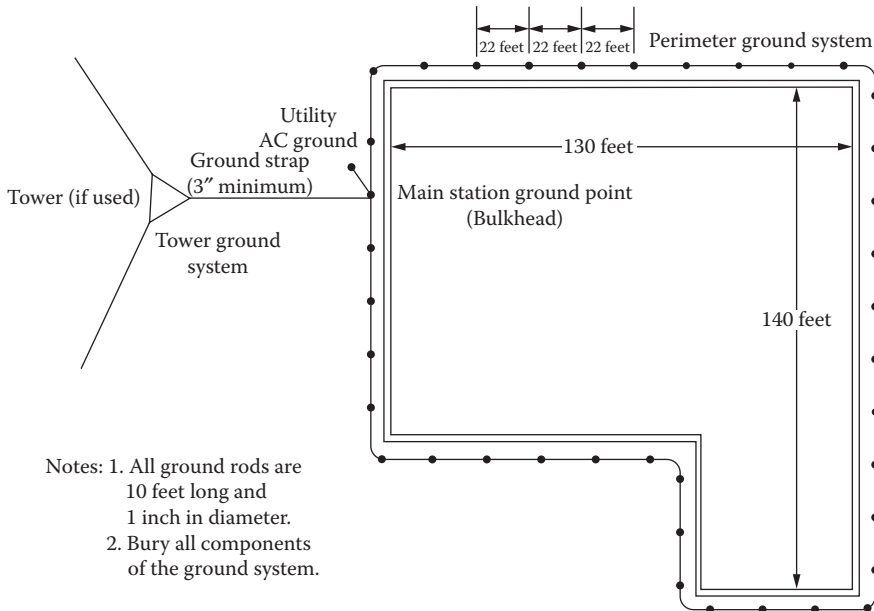
---

The bulkhead panel is the cornerstone of an effective facility grounding system [1]. The concept of the bulkhead is simple: establish one reference point to which all cables entering and leaving the equipment building are grounded and to which all transient-suppression devices are mounted. [Figure 20.6](#) shows a typical bulkhead installation for a broadcast or communications facility. The panel size depends on the spacing,

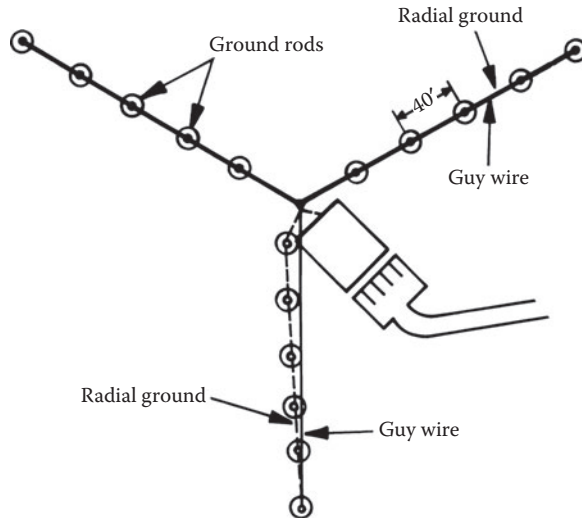




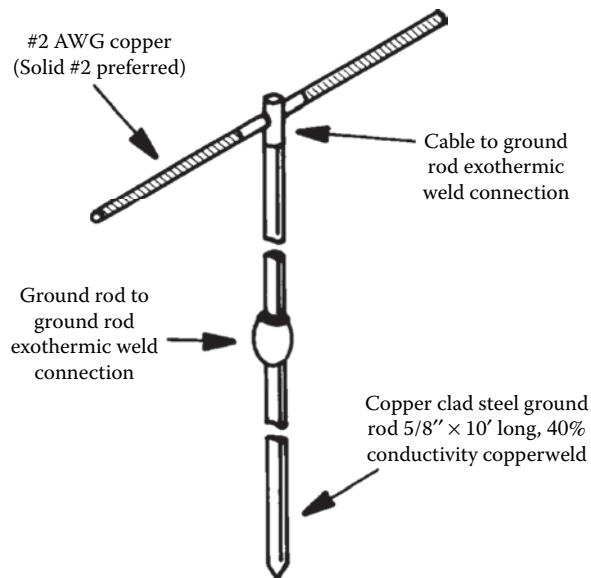
**Figure 20.1** A facility ground system using the hub-and-spoke approach. The available real estate at the site will dictate the exact configuration of the ground system. If a tower is located at the site, the tower ground system is connected to the building ground as shown.



**Figure 20.2** Facility ground using a perimeter ground-rod system. This approach works well for buildings with limited available real estate

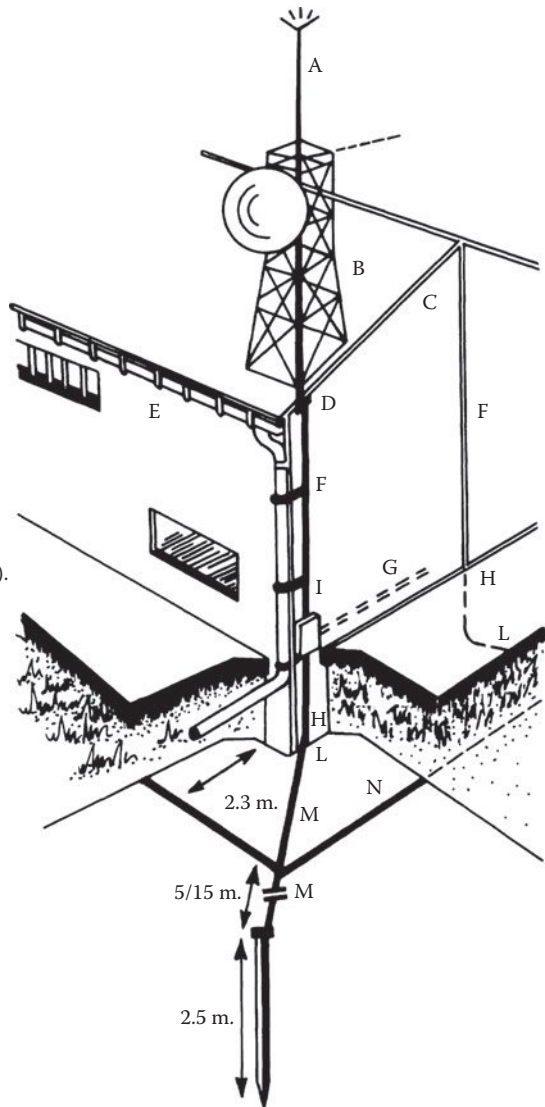


**Figure 20.3** A typical guy-anchor and tower-radial grounding scheme. The radial ground is no. 6 copper wire. The ground rods are 5/8 in. × 10 ft. (After [1].)



**Figure 20.4** Preferred bonding method for below-grade elements of the ground system. (After [1].)

- A 5 point lighting rod.  
It must be so high to cover the parabola with its safety cone.
- B Receiving antenna tower.
- C Faraday shield (bus bar or round section bar).
- D Connecting clips for Faraday shield.
- E Connecting clips for valleys or gutters.
- F Faraday shield descending cable (connected to the water tube stirrups and to any other iron object).
- G Grounding of the internal electrical system and ground of the equipment (copper round section bar).
- H Bar leading to ground (heat galvanized iron).
- I Bonding plates of several conductors (cadmium plated steel).
- L Bar-bus bar clip.
- M Zinc plated steel bus bar or stranded wire for discharge connections and dispersions. It may be buried in the earth or covered with mass concrete.
- N Grounding ring for descending cable bonding (zinc plated steel bus bar or stranded wire. It may be buried in the earth or covered with mass concrete.

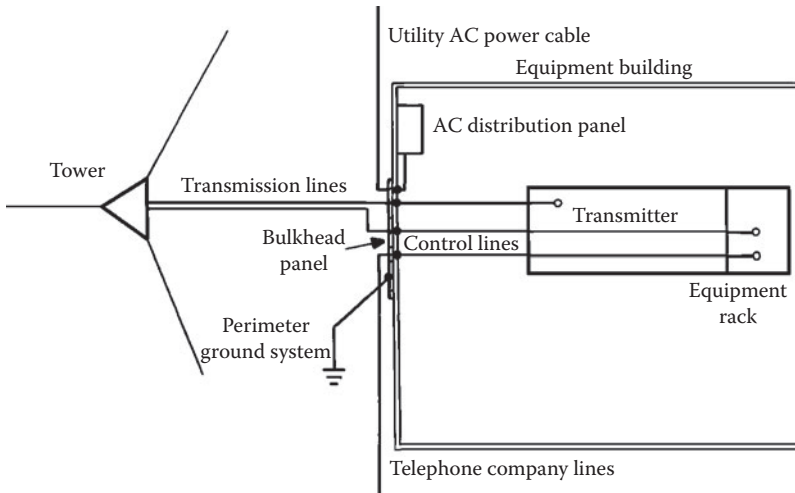


**Figure 20.5** Grounding a small microwave transmission tower.

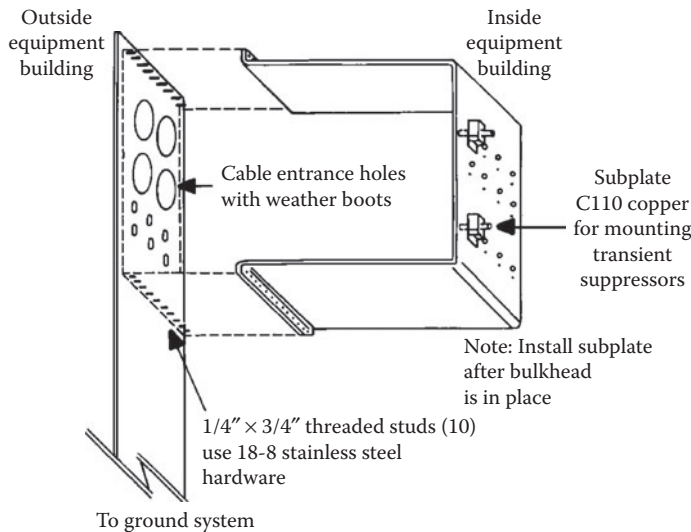
number, and dimensions of the coaxial lines, power cables, and other conduit entering or leaving the building.

To provide a weatherproof point for mounting transient-suppression devices, the bulkhead can be modified to accept a subpanel, as shown in [Figure 20.7](#). The subpanel is attached so that it protrudes through an opening in the wall and creates a secondary plate on which transient suppressors are mounted and grounded. A typical cable/suppressor-mounting arrangement for a communications site is shown in [Figure 20.8](#). To handle the currents that may be experienced during a lightning strike or large transient on the utility company ac line, the bottommost subpanel flange (which joins the subpanel to the main bulkhead) must have a total surface-contact area of at least 0.75 in.<sup>2</sup> per transient suppressor.

Because the bulkhead panel will carry significant current during a lightning strike or ac line disturbance, it must be constructed of heavy material. The recommended material is 1/8-in. C110 (solid copper) 1/2-hard. This type of copper stock weighs nearly 5-1/2 lb/ft<sup>2</sup> and is rather expensive. Installing a bulkhead, although sometimes difficult and costly, will pay dividends for the life of the facility. Use 18-8 stainless-steel mounting hardware to secure the subpanel to the bulkhead.



**Figure 20.6** The basic design of a bulkhead panel for a facility. The bulkhead establishes the grounding reference point for the plant.



**Figure 20.7** The addition of a subpanel to a bulkhead as a means of providing a mounting surface for transient-suppression components. To ensure that the bulkhead is capable of handling high surge currents, use the hardware shown. (After [1].)

Because the bulkhead panel establishes the central grounding point for all equipment within the building, it must be tied to a low-resistance (and low-inductance) perimeter ground system. The bulkhead establishes the *main facility ground point*, from which all grounds inside the building are referenced. A typical bulkhead installation for a small communications site is shown in [Figure 20.9](#).

### 20.2.1 Bulkhead Panel

A properly installed bulkhead panel will exhibit lower impedance and resistance to ground than any other equipment or cable grounding point at the facility [1]. Waveguide and coax line grounding kits should be installed at the bulkhead panel as well as at the tower. Dress the kit tails downward at a straight 45° angle using 3/8-in. stainless-steel hardware to the panel. Position the stainless-steel lug at the tail end,

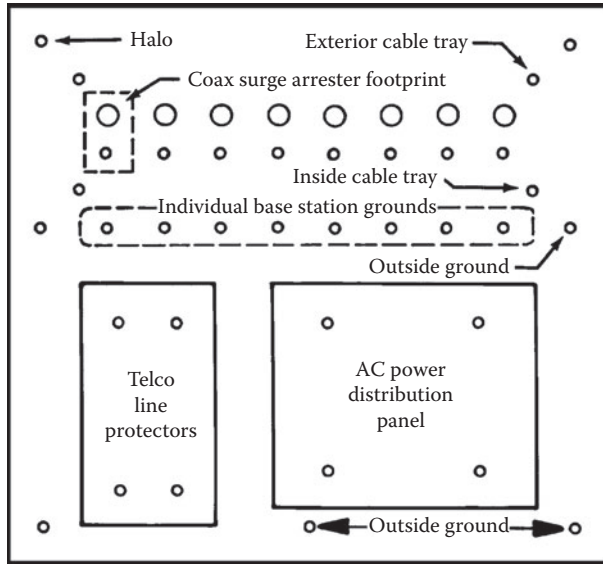


Figure 20.8 Mounting-hole layout for a communications site bulkhead subpanel.

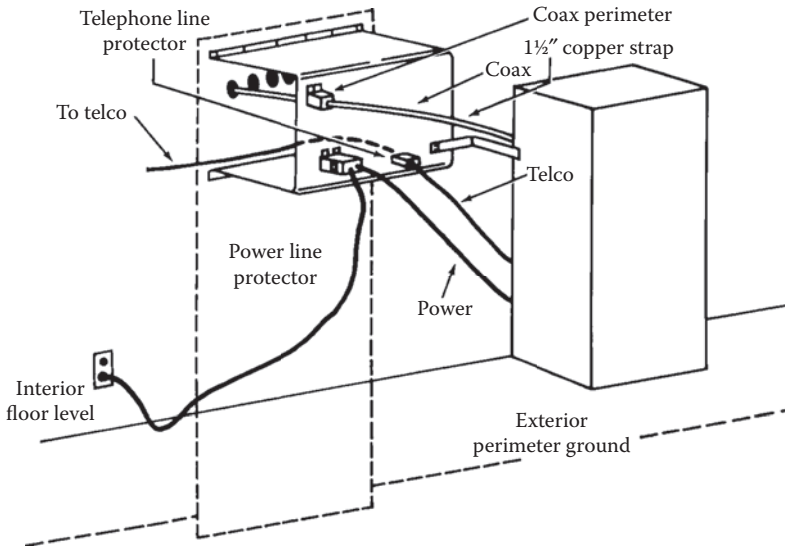
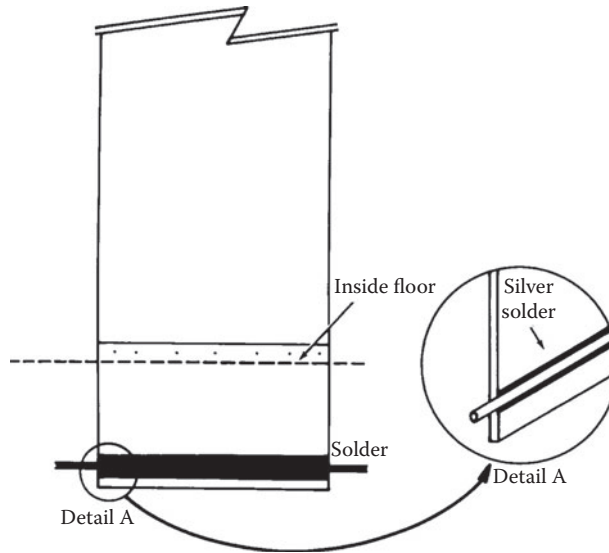


Figure 20.9 Bulkhead installation at a small communications site. (After [1].)

flat against a cleaned spot on the panel. Joint compound will be needed for aluminum and is recommended for copper panels.

Because the bulkhead panel will be used as the central grounding point for all the equipment inside the building, the lower the inductance to the perimeter ground system, the better. The best arrangement is to simply extend the bulkhead panel down the outside of the building, below grade, to the perimeter ground system. This will give the lowest resistance and the smallest inductive voltage drop. This approach is illustrated in Figure 20.10.

If cables are used to ground the bulkhead panel, secure the interconnection to the outside ground system along the bottom section of the panel. Use multiple no. 1/0 or larger copper wire or several solid-copper straps. If using strap, attach with stainless-steel hardware, and apply joint compound for aluminum bulkhead panels. Clamp and Cadweld, or silver-solder for copper/brass panels. If no. 1/0 or larger



**Figure 20.10** The proper way to ground a bulkhead panel and provide a low-inductance path for surge currents stripped from cables entering and leaving the facility. The panel extends along the building exterior to below grade. It is silver-soldered to a no. 2/0 copper wire that interconnects with the outside ground system. (After [1].)

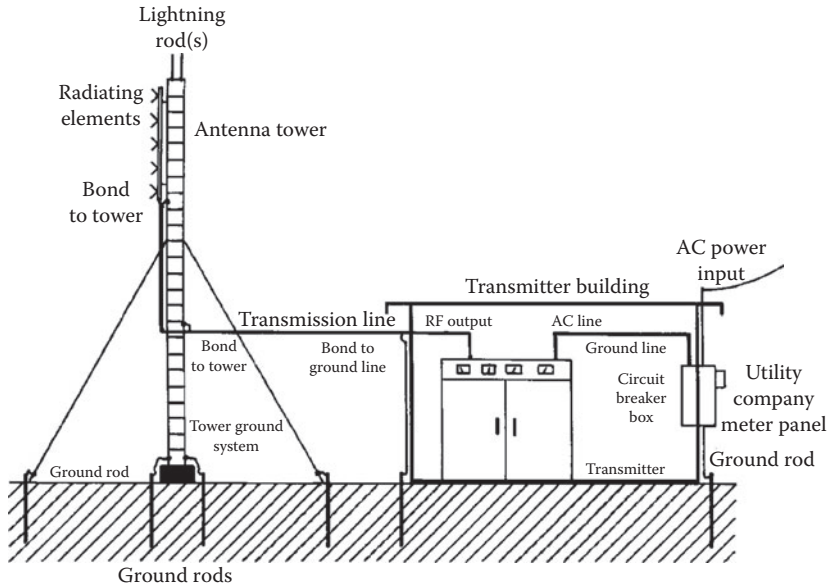
wire is used, employ crimp lug and stainless-steel hardware. Measure the dc resistance. It should be less than  $0.01 \Omega$  between the ground system and the panel. Repeat this measurement on an annual basis.

If the antenna feed lines do not enter the equipment building via a bulkhead panel, treat them in the following manner:

- Mount a feed-line ground bar on the wall of the building approximately 4 in. below the feed-line entry point.
- Connect the outer conductor of each feed line to the feed-line ground bar using an appropriate grounding kit.
- Connect a no. 1/0 cable or 3- to 6-in.-wide copper strap between the feed-line ground bar and the external ground system. Make the joint a Cadweld or silver-solder connection.
- Mount coaxial arrestors on the edge of the bar.
- Weatherproof all connections.

## 20.2.2 Lightning Protectors

A variety of lightning arrestors are available for use on coaxial transmission lines, utility ac feeds, and telephone cables. The protector chosen must be carefully matched to the requirements of the application. Do not use air-gap protectors because these types are susceptible to air pollution, corrosion, temperature, humidity, and manufacturing tolerances. The turn-on speed of an air gap device is a function of all of the foregoing elements. A simple gas-tube-type arrestor is an improvement, but neither of these devices will operate reliably to protect shunt-fed cavities, isolators, or receivers that include static drain inductors to ground (which most have). Such voltage-sensitive crowbar devices are short-circuited by the dc path to ground found in these circuits. The inductive change in current per unit time ( $\Delta i/dt$ ) voltage drop is usually not enough to fire the protector, but it can be sufficient to destroy the inductor and then the receiver front end. Instead, select a protector that does not have dc continuity on the coaxial center pin from input to output. Such units have a series capacitor between the gas tube and the equipment center pin that will allow the voltage to build up so that the arrestor can fire properly.



**Figure 20.11** A common, but not ideal, grounding arrangement for a transmission facility using a grounded tower. A better configuration involves the use of a bulkhead panel through which all cables pass into and out of the equipment building.

### 20.2.2.1 Typical Installation

Figure 20.11 illustrates a common grounding arrangement for a remotely located grounded-tower (FM, TV, or microwave radio) transmitter plant. The tower and guy wires are grounded using 10-ft-long copper-clad ground rods. The antenna is bonded to the tower, and the transmission line is bonded to the tower at the point where it leaves the structure and begins the horizontal run into the transmitter building. Before entering the structure, the line is bonded to a ground rod through a connecting cable. The transmitter itself is grounded to the transmission line and to the ac power-distribution system ground. This, in turn, is bonded to a ground rod where the utility feed enters the building. The goal of this arrangement is to strip all incoming lines of damaging overvoltages before they enter the facility. One or more lightning rods are mounted at the top of the tower structure. The rods extend at least 10 ft above the highest part of the antenna assembly.

Such a grounding configuration, however, has built-in problems that can make it impossible to provide adequate transient protection to equipment at the site. Look again at the example. To equipment inside the transmitter building, two grounds actually exist: the utility company ground and the antenna ground. One ground will have a lower resistance to earth, and one will have a lower inductance in the connecting cable or copper strap from the equipment to the ground system.

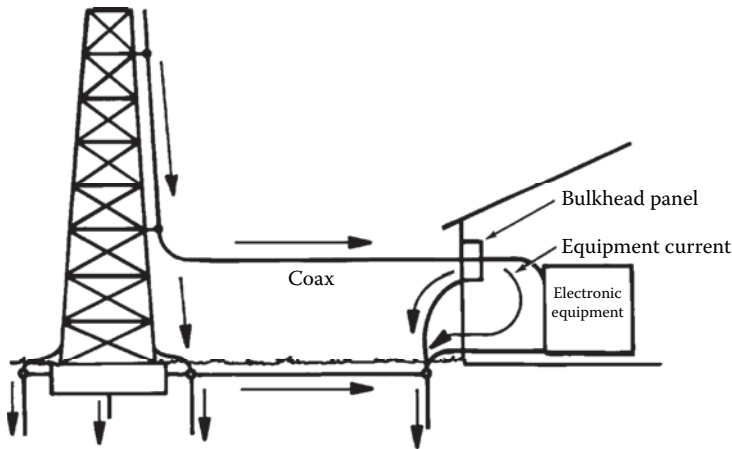
Using the Figure 20.11 example, assume that a transient overvoltage enters the utility company meter panel from the ac service line. The overvoltage is clamped by a protection device at the meter panel, and the current surge is directed to ground. But *which ground*, the utility ground or the antenna ground?

The utility ground surely will have a lower inductance to the current surge than the antenna ground, but the antenna probably will exhibit a lower resistance to ground than the utility side of the circuit. Therefore, the surge current will be divided between the two grounds, placing the transmission equipment in series with the surge suppressor and the antenna ground system. A transient of sufficient potential will damage the transmission equipment.

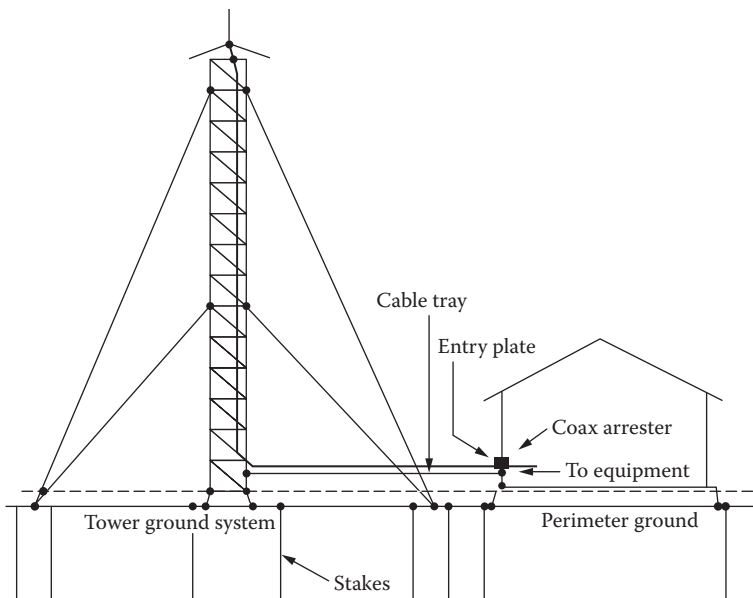
Transients generated on the antenna side because of a lightning discharge are no less troublesome. The tower is a conductor, and any conductor is also an inductor. A typical 150-ft self-supporting tower

may exhibit as much as 40  $\mu\text{H}$  inductance. During a fast-rise-time lightning strike, an instantaneous voltage drop of 360 kV between the top of the tower and the base is not unlikely. If the coax shield is bonded to the tower 15 ft above the earth (as shown in the previous figure), 10% of the tower voltage drop (36 kV) will exist at that point during a flash. Figure 20.12 illustrates the mechanisms involved.

The only way to ensure that damaging voltages are stripped off all incoming cables (coax, ac power, and telephone lines) is to install a bulkhead entrance panel and tie all transient-suppression hardware to it. Configuring the system as shown in Figure 20.13 strips away all transient voltages through the use of a single-point ground. The bulkhead panel is the ground reference for the facility. With such a design, secondary surge current paths do not exist, as illustrated in Figure 20.14.

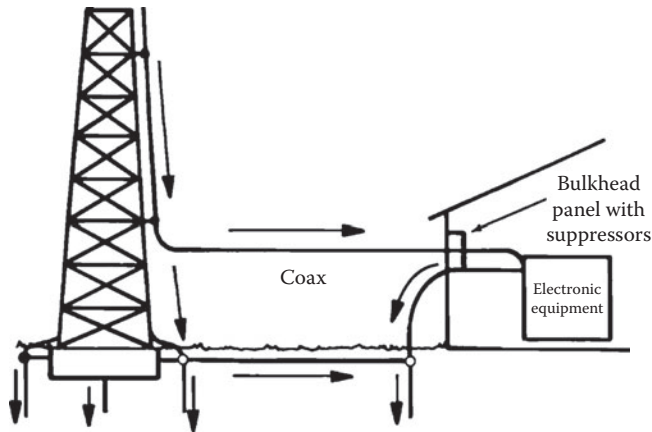


**Figure 20.12** The equivalent circuit of the facility shown in Figure 20.23. Note the discharge current path through the electronic equipment.



**Figure 20.13** The preferred grounding arrangement for a transmission facility using a bulkhead panel. With this configuration, all damaging transient overvoltages are stripped off the coax, power, and telephone lines before they can enter the equipment building.





**Figure 20.14** The equivalent circuit of the facility shown in Figure 20.25. Discharge currents are prevented from entering the equipment building.

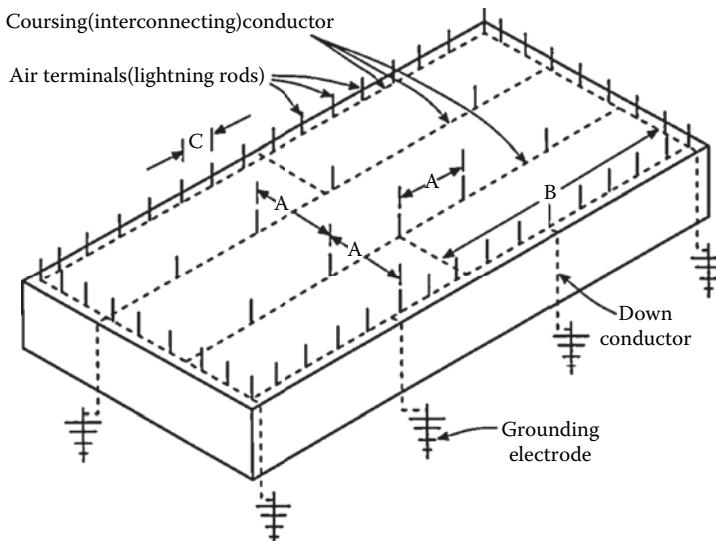
Protecting the building itself is another important element of lightning surge protection. Figure 20.15 shows a common system using multiple lightning rods. As specified by NFPA 78, the dimensions given in the figure are as follows:

- A = 50-ft maximum spacing between air terminals
- B = 150-ft maximum length of a coursing conductor permitted without connection to a main perimeter or download conductor
- C = 20- or 25-ft maximum spacing between air terminals along an edge

### 20.2.3 Checklist for Proper Grounding

A methodical approach is necessary in the design of a facility ground system. Consider the following points:

1. Install a bulkhead panel to provide mechanical support, electric grounding, and lightning protection for coaxial cables, power feeds, and telephone lines entering the equipment building.



**Figure 20.15** Conduction lightning-protection system for a large building. (From [5]. Used with permission.)

2. Install an internal ground bus using no. 2 or larger solid-copper wire. (At transmission facilities, use copper strap that is at least 3 in. wide.) Form a *star* grounding system. At larger installations, form a *star-of-stars* configuration. Do not allow ground loops to exist in the internal ground bus. Connect the following items to the building internal ground system:
  - Chassis racks and cabinets of all hardware
  - All auxiliary equipment
  - Battery charger
  - Switchboard
  - Conduit
  - Metal raceway and cable tray
3. Install a tower earth ground array by driving ground rods and laying radials as required to achieve a low earth ground impedance at the site.
4. Connect outside metal structures to the earth ground array (towers, metal fences, metal buildings, and guy-anchor points).
5. Connect the power-line ground to the array. Follow local electrical code to the letter.
6. Connect the bulkhead to the ground array through a low-inductance, low-resistance bond.
7. Do not use soldered-only connections outside the equipment building. Crimped, brazed, and exothermic (Cadwelded) connections are preferable. For a proper bond, all metal surfaces must be cleaned, any finish removed to bare metal, and surface preparation compound applied (where necessary). Protect all connections from moisture by appropriate means (sealing compound and heat-sink tubing).

## 20.3 AC System Grounding Practices

---

Installing an effective ground system to achieve a good earth-to-grounding-electrode interface is only half the battle for a facility designer. The second, and equally important, element of any ground system is the configuration of grounding conductors inside the building. Many different methods can be used to implement a ground system, but some conventions always should be followed to ensure a low-resistance (and low-inductance) layout that will perform as required. Proper grounding is important whether or not the facility is located in a high-RF field.

### 20.3.1 Building Codes

As outlined previously in this chapter, the primary purpose of grounding electronic hardware is to prevent electric shock hazard. The National Electrical Code (NEC) and local building codes are designed to provide for the safety of the workplace. Local codes always should be followed. Occasionally, code sections are open to some interpretation. When in doubt, consult a field inspector. Codes constantly are being changed or expanded because new situations arise that were not anticipated when the codes were written. Sometimes, an interpretation will depend upon whether the governing safety standard applies to building wiring or to a factory-assembled product to be installed in a building. Underwriters Laboratories (UL) and other qualified testing organizations examine products at the request and expense of manufacturers or purchasers, and list products if the examination reveals that the device or system presents no significant safety hazard when installed and used properly.

Municipal and county safety inspectors generally accept UL and other qualified testing laboratory certification listings as evidence that a product is safe to install. Without a listing, the end user might not be able to obtain the necessary wiring permits and inspection sign-off. On-site wiring must conform with local wiring codes. Most codes are based on the NEC. Electrical codes specify wiring materials, wiring devices, circuit protection, and wiring methods.

### 20.3.1.1 Single-Point Ground

Single-point grounding is the basis of any properly designed facility ground network. Fault currents and noise should have only one path to the facility ground. Single-point grounds can be described as *star* systems in which radial elements circle out from a central hub. A star system is illustrated in Figure 20.16. Note that all equipment grounds are connected to a *main ground point*, which is then tied to the facility ground system. Multiple ground systems of this type can be cascaded as needed to form a *star-of-stars* facility ground system. The key element in a single-point ground is that each piece of equipment has one ground reference. Fault energy and noise then are efficiently drained to the outside earth ground system. The single-point ground is basically an extension of the bulkhead panel discussed previously.

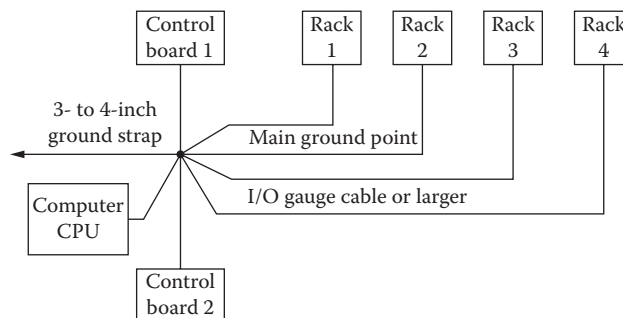
### 20.3.2 Isolated Grounding

Isolated grounding schemes, where the signal reference plane is isolated from equipment ground but connected to an *isolated* electrode in the earth, do not work, are unsafe, and violate the NEC [2]. It is thought by some people that the isolated earth connection is *clean* because there is no connection between it and the *dirty* system ground connection at the service entrance. The clean, isolated earth connection is also viewed (incorrectly) as a point where noise currents can flow into the earth and be dissipated. Kirchoff's current law teaches that any current flowing into the isolated ground must return to the source through another earth connection. Current cannot be dissipated. It must always return to its source. Even lightning current is not dissipated into the earth. It must have a return path (i.e., the electrostatic and electromagnetic fields that created the charge buildup and the lightning strike in the first place).

Consider what might happen if such a system were subjected to a lightning strike. Assume that a transient current of 2000 A flows into the earth and through an earth resistance of 5  $\Omega$  between the system ground electrode and the isolated electrode. A more realistic resistance might be even higher, perhaps 25  $\Omega$ ; 2000 A flowing through 5  $\Omega$  results in a voltage drop or transient potential of 10,000 V between the two electrodes. Because this potential is impressed between the equipment frame (system ground electrode) and the signal reference plane (isolated electrode), it could result in equipment damage and personnel hazard. Dangerous potential differences between grounding subsystems can be reduced by bonding together all earth electrodes at a facility.

A facility ground system, then, can be defined as an electrically interconnected system of multiple conducting paths to the earth electrode or system of electrodes. The facility grounding system includes all electrically interconnected grounding subsystems such as:

- The equipment grounding subsystem
- Signal reference subsystem
- Fault protection subsystem
- Lightning protection subsystem



**Figure 20.16** Typical facility grounding system. The *main facility ground point* is the reference from which all grounding is done at the plant. If a bulkhead entrance panel is used, it will function as the main ground point.

Isolated ground (IG) receptacles, which are a version of single-point grounding, are permitted by the NEC. Proper application of IG receptacles is very important. They must be used with an insulated equipment grounding conductor, not a bare conductor. Also, only metallic conduit should be used.

### 20.3.3 Separately Derived Systems

A separately derived system is a premises wiring system whose power is derived from generator, transformer, or converter windings and that has no direct electrical connection, including a solidly connected grounded circuit conductor, to supply conductors originating in another system [3]. Solidly grounded, wye-connected, isolation transformers used to supply power to computer room equipment are examples of separately derived systems [2]. Figure 20.17 illustrates the bonding and grounding requirements of separately derived systems. NEC 250-26 permits the bonding and grounding connections to be made at the source of the separately derived system or at the first disconnecting means. Other examples of separately derived systems include generators and UPS systems. Note that all earth electrodes are bonded together via the equipment grounding conductor system. This is consistent with the recommendations listed in NEC 250-86.

### 20.3.4 Grounding Terminology

- *Grounded conductor.* A system or circuit conductor that is intentionally grounded [3].
- *Equipment grounding conductor.* The conductor used to connect the non-current-carrying metal parts of equipment, raceways, and other enclosures to the system grounded conductor, the grounding electrode conductor, or both, at the service equipment or at the source of a separately derived system [3].
- *Main bonding jumper.* The connection between the grounded circuit conductor and the equipment grounding conductor at the service [3].
- *Grounding electrode conductor.* The conductor used to connect the grounding electrode to the equipment grounding conductor, to the grounded conductor, or to both, of the circuit at the service equipment or at the source of a separately derived system [3].
- *Service.* The conductors and equipment for delivering energy from the electricity supply system to the wiring system of the premises served [3].

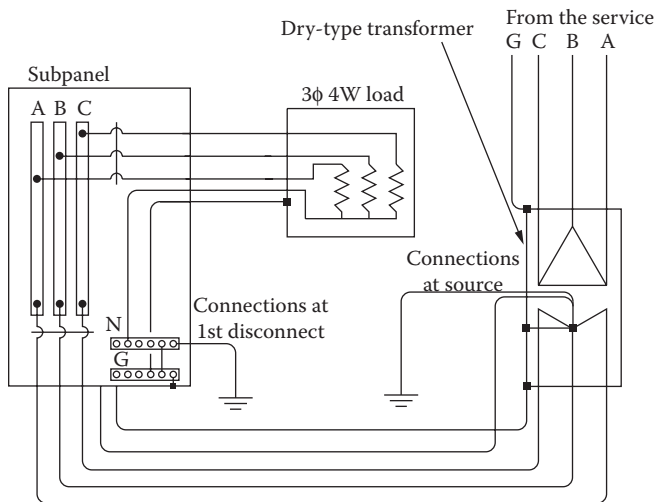


Figure 20.17 Basic scheme of the separately derived power system. (From [2]. Used with permission.)

- *Service conductors.* The supply conductors that extend from the street main or from transformers to the service equipment of the premises supplied [3].
- *Service equipment.* The necessary equipment, usually consisting of a circuit breaker or switch and fuses, and their accessories, located near the point of entrance of supply conductors to a building or other structure, or an otherwise defined area, and intended to constitute the main control and means of cutoff of the supply [3].
- *Equipotential plane.* A mass of conducting material that offers a negligible impedance to current flow, thus producing zero volts (equipotential) between points on the plane.
- *Floating signal grounding.* A nongrounding system in which all electronic signal references are isolated from ground.
- *Single-point grounding.* A grounding system in which all electronic signal references are bonded together and grounded at a single point.
- *Multipoint grounding.* A grounding system in which all electronic signal references are grounded at multiple points.

### 20.3.5 Facility Ground System

Figure 20.18 illustrates a star grounding system as applied to an ac power-distribution transformer and circuit-breaker panel. Note that a central ground point is established for each section of the system: one in the transformer vault and one in the circuit-breaker box. The breaker ground ties to the transformer vault ground, which is connected to the building ground system. Figure 20.19 shows single-point grounding applied to a data processing center. Note how individual equipment groups are formed into a star grounding system, and how different groups are formed into a star-of-stars configuration. A similar approach can be taken for a data processing center using multiple modular power center (MPC) units, as shown in Figure 20.20. The terminal mounting wall is the reference ground point for the room.

Grounding extends to all conductive elements of the data processing center. As illustrated in Figure 20.21, the raised-floor supports are integrated into the ground system, in addition to the metal work of the building. The flooring is bonded to form a mesh grounding plane that is tied to the central ground reference point of the room. This is another natural extension of the bulkhead concept discussed previously. Figure 20.22 shows connection detail for the raised-floor supports. Make sure to use a flooring system that can be bolted together to form secure electrical — as well as mechanical — connections.

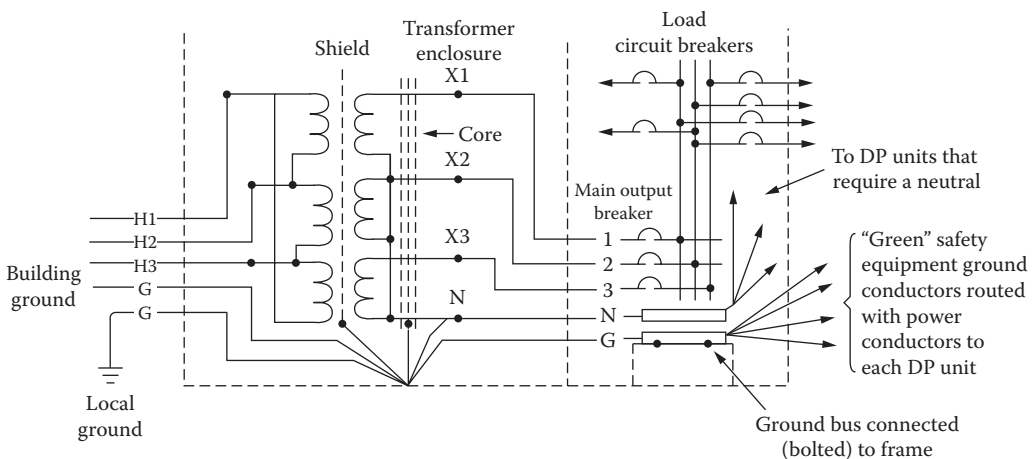


Figure 20.18 Single-point grounding applied to a power-distribution system. (After [6].)

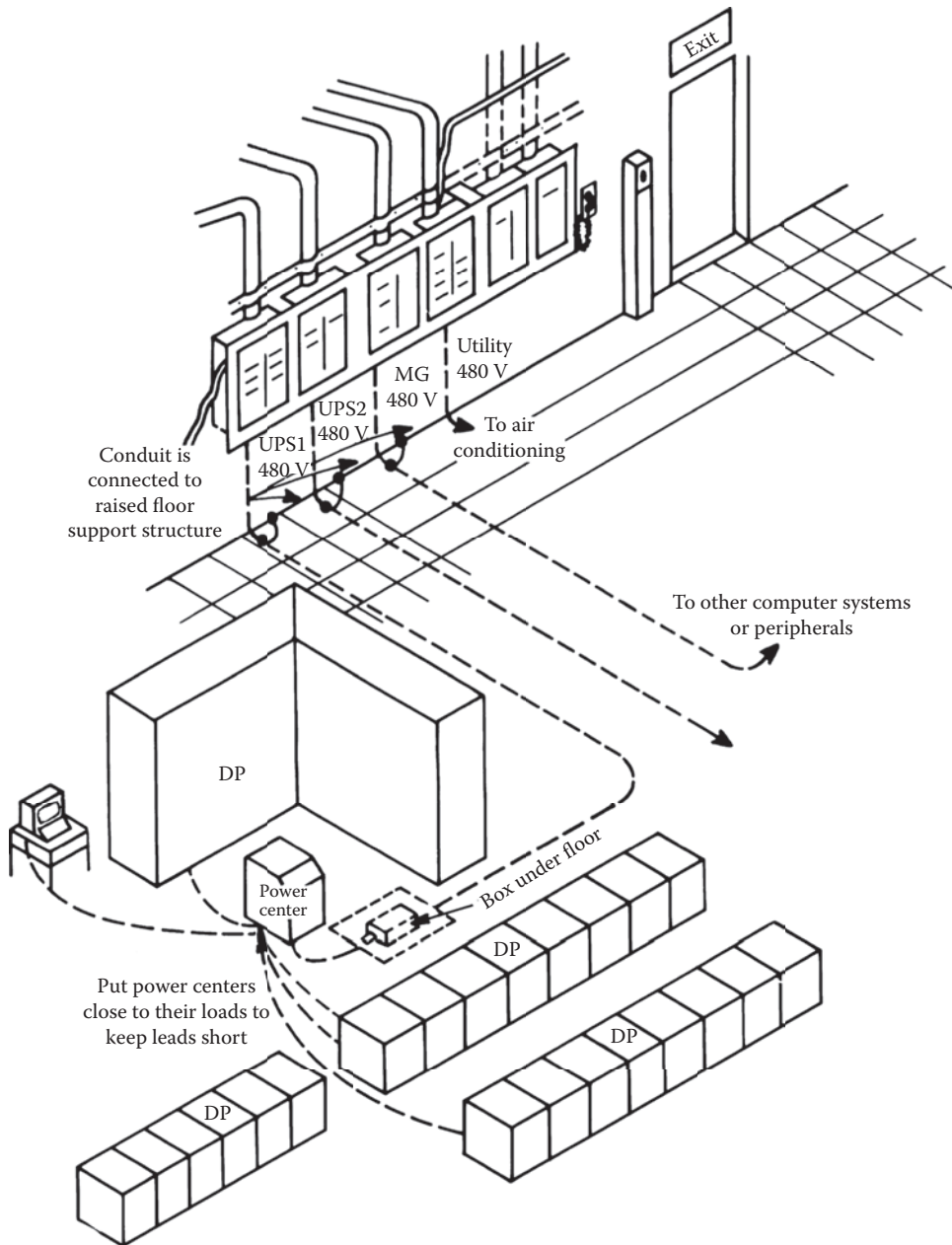
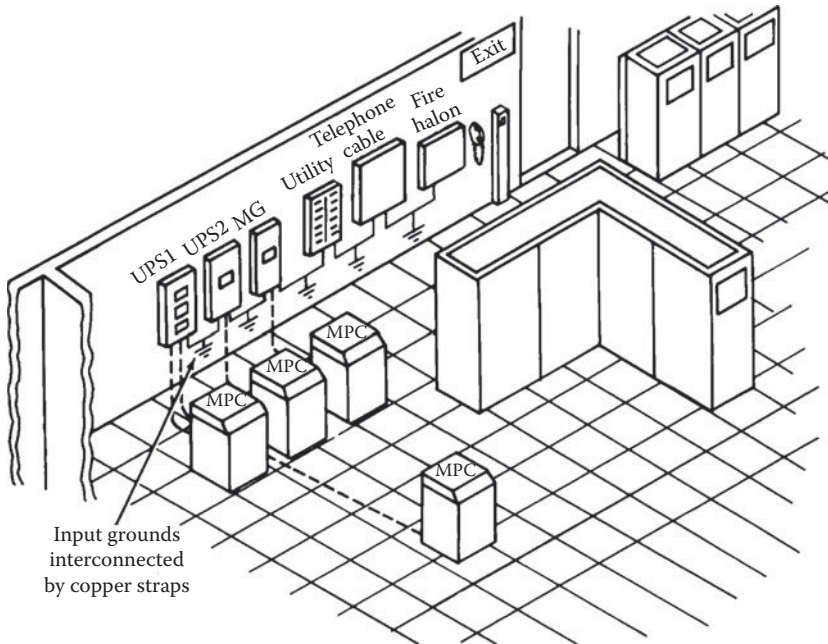


Figure 20.19 Configuration of a star-of-stars grounding system at a data processing facility. (After [6].)

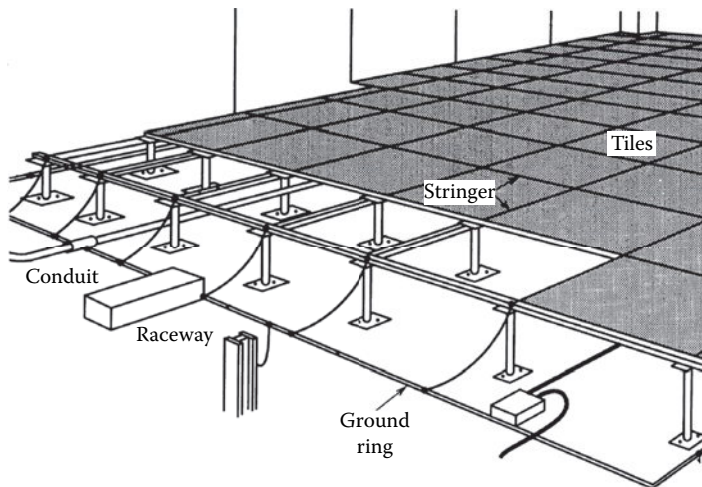
Figure 20.23 shows the recommended grounding arrangement for a typical communications facility. The building ground system is constructed using heavy-gauge copper wire (no. 4 or larger) if the studio is not located in an RF field, or a wide copper strap (3-in. minimum) if the facility is located near an RF energy source. Figure 20.24 gives a functional view of the plan shown in Figure 20.23. Note the bulkhead approach.

Run the strap or cable from the perimeter ground to the main facility ground point. Branch out from the main ground point to each major piece of equipment and to the various equipment rooms. Establish a *local ground point* in each room or group of racks. Use a separate ground cable for each piece of equipment (no. 12 gauge or larger). Figure 20.25 shows the grounding plan for a facility incorporating





**Figure 20.20** Establishing a star-based, single-point ground system using multiple modular power centers. (After [6].)



**Figure 20.21** Grounding plan for a raised-floor support system.

a grounding halo. Equipment grounding is handled by separate conductors tied to the bulkhead panel (entry plate). A *halo* ground is constructed around the perimeter of the room. Cable trays are tied into the halo. All electronic equipment is grounded to the bulkhead to prevent ground-loop paths. In this application, the halo serves essentially the same function as the raised-floor ground plane in the data processing center.

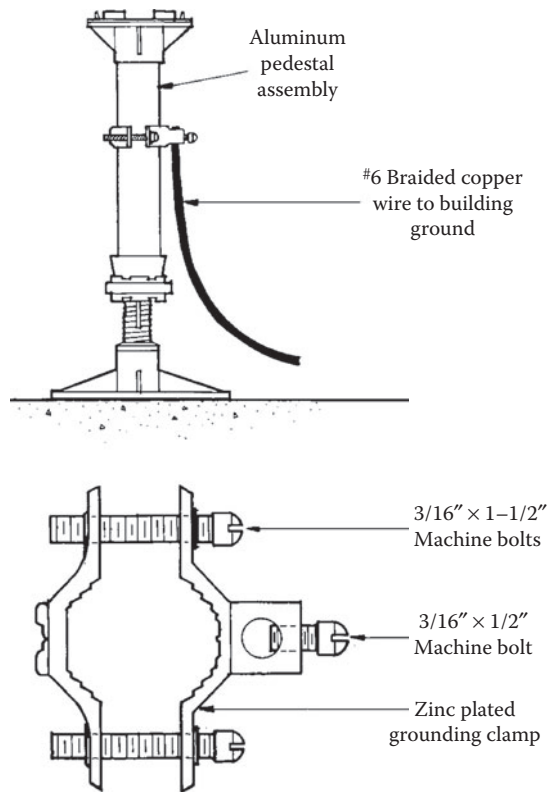
The ac line ground connection for individual pieces of equipment often presents a built-in problem for the system designer. If the equipment is grounded through the chassis to the equipment-room ground point, a ground loop can be created through the green-wire ground connection when the equipment is plugged in. The solution to this problem involves careful design and installation of the ac power-distribution system to minimize ground-loop currents, while at the same time providing the required

protection against ground faults. Some equipment manufacturers provide a convenient solution to the ground-loop problem by isolating the signal ground from the ac and chassis ground. This feature offers the user the best of both worlds: the ability to create a signal ground system and ac ground system that are essentially free of interaction and ground loops. Do not confuse this isolated signal ground with the isolated ground system described previously. In this context, *isolated* refers only to the equipment input/output (signal) connections, not the equipment chassis; there is still only one integrated ground system for the facility, and all equipment is tied to it.

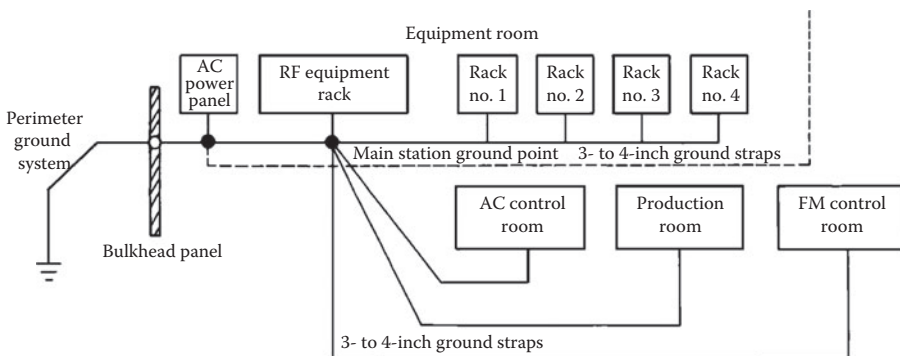
It should be emphasized that the design of a ground system must be considered as an integrated package. Proper procedures must be used at all points in the system. It takes only one improperly connected piece of equipment to upset an otherwise perfect ground system. The problems generated by a single grounding error can vary from trivial to significant, depending upon where in the system the error exists. This consideration leads, naturally, to the concept of ground-system maintenance for a facility. Check the ground network from time to time to ensure that no faults or errors have occurred. Anytime new equipment is installed, or old equipment is removed from service, careful attention must be given to the possible effects that such work will have on the ground system.

**20.3.5.1 Grounding Conductor Size**

The NEC and local electrical codes specify the minimum wire size for grounding conductors. The size varies, depending upon the rating of the current-carrying conductors. Code typically permits a smaller ground conductor than hot conductors. It is recommended, however, that the same size wire be used for both ground lines and hot lines. The additional cost



**Figure 20.22** Bonding detail for the raised-floor support system.



**Figure 20.23** Typical grounding arrangement for individual equipment rooms at a communications facility. The ground strap from the main ground point establishes a *local ground point* in each room, to which all electronic equipment is bonded.



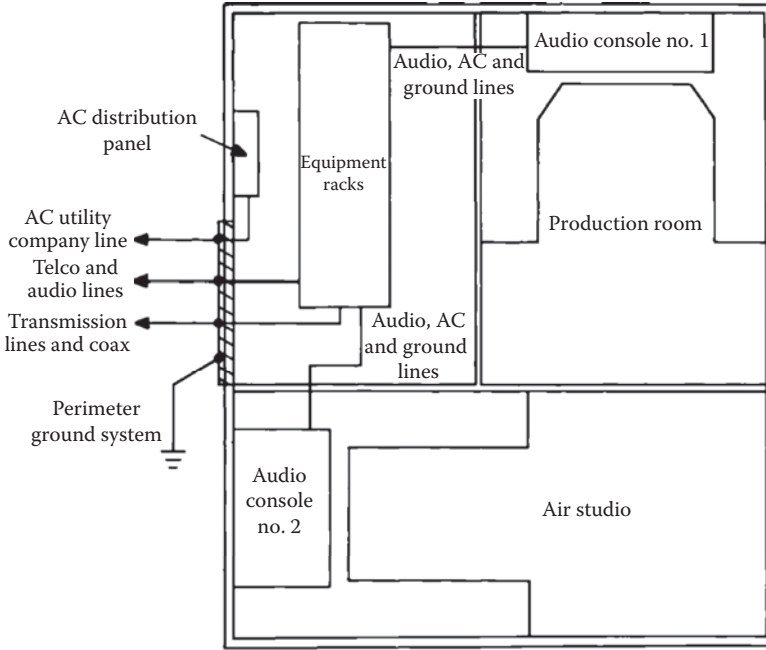


Figure 20.24 Physical implementation of the facility shown in Figure 20.23.

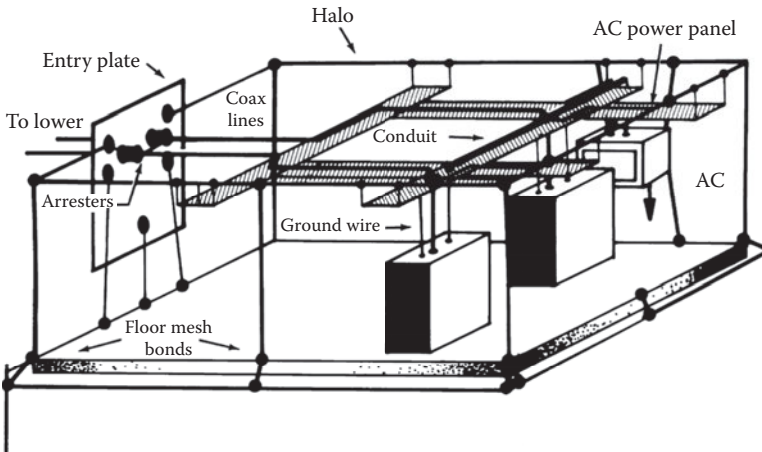


Figure 20.25 Bulkhead-based ground system including a grounding halo.

involved in the larger ground wire often is offset by the use of a single size of cable. Furthermore, better control over noise and fault currents is achieved with a larger ground wire.

It is recommended that separate insulated ground wires be used throughout the ac distribution system. Do not rely on conduit or raceways to carry the ground connection. A raceway interface that appears to be mechanically sound may not provide the necessary current-carrying capability in the event of a phase-to-ground fault. Significant damage can result if a fault occurs in the system. When the electrical integrity of a breaker panel, conduit run, or raceway junction is in doubt, fix it. Back up the mechanical connection with a separate ground conductor of the same size as the current-carrying conductors. Loose joints have been known to shower sprays of sparks during phase-to-ground faults, creating a fire hazard. Secure the ground cable using appropriate hardware. Clean attachment points of any paint or dirt accumulation. Properly label all cables.

Structural steel, compared with copper, is a poor conductor at any frequency. At dc, steel has a resistivity 10 times that of copper. As frequency rises, the skin effect is more pronounced because of the magnetic effects involved. A no. 6 copper wire can have less RF impedance than a 12-in. steel “I” beam. Furthermore, because of their bolted, piecemeal construction, steel racks and building members should not be depended upon alone for circuit returns.

### 20.3.5.2 High-Frequency Effects

A significant amount of research has been conducted into why the 60 Hz power grounding system is incapable of conducting RF signals to the common reference point, thereby equalizing existing differences in potential [4]. A properly designed power grounding system is of sufficiently low impedance at 60 Hz to equalize any potential differences so that enclosures, raceways, and all grounded metal elements are at the same reference (ground) potential. However, at higher frequencies, equalization is prevented because of increased impedance.

The impedance of a conductor consists of three basic components: resistance, capacitive reactance, and inductive reactance. Although the inductance  $L$  (in Henrys) will be constant for a conductor of a given length and cross-sectional area, the inductive reactance  $X_L$  will vary according to the frequency  $f$  of the applied voltage as follows:

$$X_L = 2\pi fL \quad (20.2)$$

Therefore, at 60 Hz, the inductive reactance will be  $377 \times L$ ; at 30 MHz, it will be  $(188.5 \times 10^6) \times L$ . It is evident, then, that at 60 Hz the equipment grounding conductor is a short circuit, but at 30 MHz, it is effectively an open circuit.

In addition to increased inductive reactance at higher frequencies, there are also stray capacitance and stray inductance between adjacent conductors or between conductors and adjacent grounded metal, as well as resonance effects. These factors combine to yield an increase in apparent conductor impedance at higher frequencies.

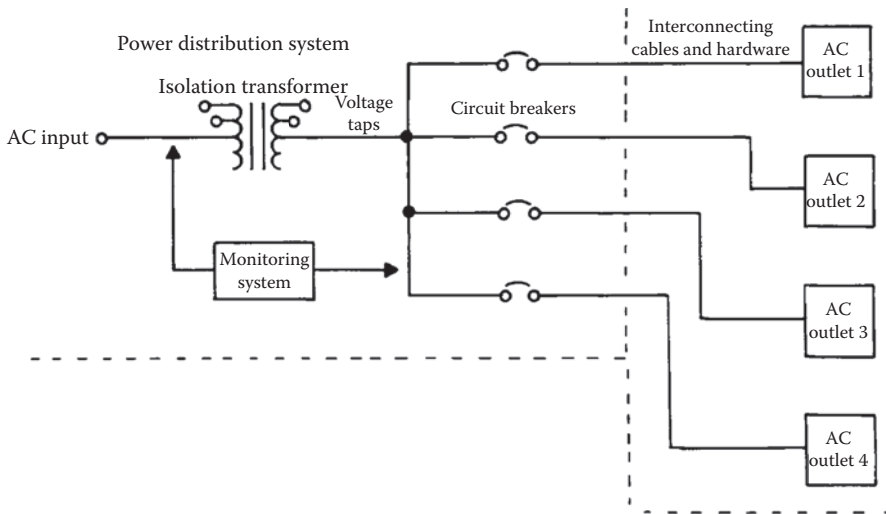
If conductors are connected in a mesh or grid to form a multitude of low-impedance loops in parallel, there will be little voltage difference between any two points on the grid at all frequencies from 60 Hz up to a frequency where the length of one side of the square represents about 1/10 wavelength. A grid made up of 2-ft squares (such as a raised computer-room floor) will at any point provide an effective equipotential ground reference point for signals up to perhaps 30 MHz.

## 20.3.6 Power-Center Grounding

A modular power center, commonly found in computer-room installations, provides a comprehensive solution to ac power-distribution and ground-noise considerations. Such equipment is available from several manufacturers, with various options and features. A computer power-distribution center generally includes an isolation transformer designed for noise suppression, distribution circuit breakers, power-supply cables, and a status-monitoring unit. The system concept is shown in [Figure 20.26](#). Input power is fed to an isolation transformer with primary taps to match the ac voltage required at the facility. A bank of circuit breakers is included in the chassis, and individual preassembled and terminated cables supply ac power to the various loads. A status-monitoring circuit signals the operator if any condition is detected outside normal parameters.

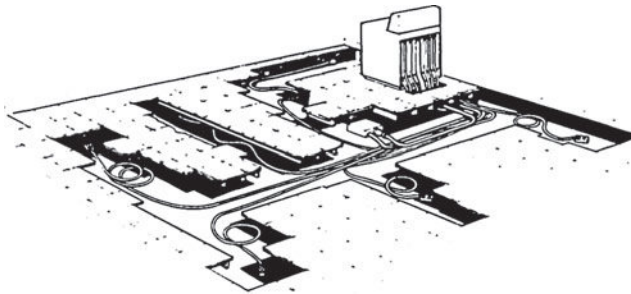
The ground system is an important component of the MPC. A unified approach, designed to prevent noise or circulating currents, is taken to grounding for the entire facility. This results in a clean ground connection for all equipment on-line.

The use of a modular power center can eliminate the inconvenience associated with rigid conduit installations. Distribution systems also are expandable to meet future facility growth. If the plant ever is relocated, the power center can move with it. MPC units usually are expensive. However, considering the costs of installing circuit-breaker boxes, conduit, outlets, and other hardware on-site by a licensed electrician,

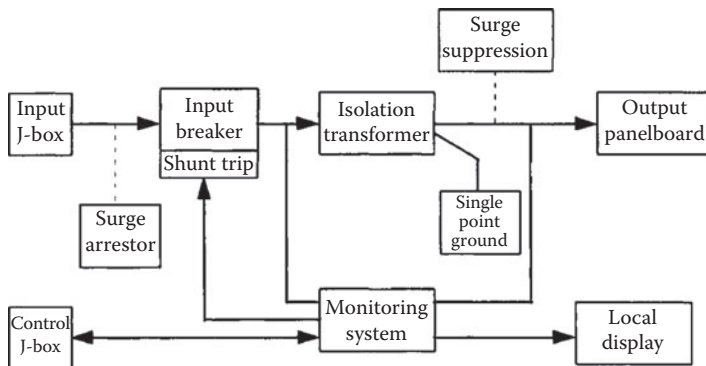


(a)

A typical computer room application



(b)



(c)

**Figure 20.26** The basic concept of a computer-room modular power center: (a) basic line drawing of system, (b) typical physical implementation, (c) functional block diagram. Both single- and multiphase configurations are available. When ordering an MPC, the customer can specify cable lengths and terminations, making installation quick and easy. (After [7].)

cian, the power-center approach may be economically viable. The use of a power center also will make it easier to design a standby power system for the facility. Many computer-based operations do not have a standby generator on-site. Depending on the location of the facility, it might be difficult or even impossible to install a generator to provide standby power in the event of a utility company outage. However, by using the power-center approach to ac distribution for computer and other critical load equipment, an uninterruptible power system can be installed easily to power only the loads that are required to keep the facility operating. With a conventional power-distribution system — where all ac power to the building, or a floor of the building, is provided by a single large circuit-breaker panel — separating the critical loads from other nonessential loads (such as office equipment, lights, and heating equipment) can be an expensive detail.

### 20.3.6.1 Isolation Transformers

One important aspect of an MPC is the isolation transformer. The transformer serves to:

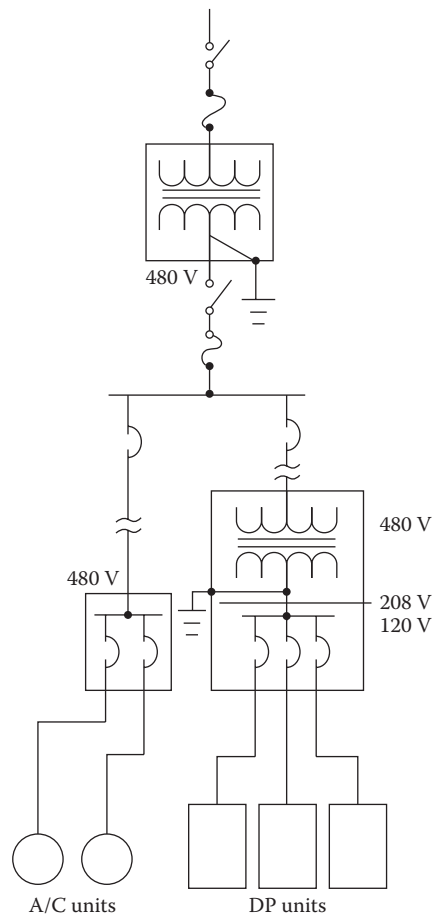
- Attenuate transient disturbances on the ac supply lines
- Provide voltage correction through primary-side taps
- Permit the establishment of a local ground reference for the facility served

Whether or not an MPC is installed at a facility, consideration should be given to the appropriate use of an isolation transformer near a sensitive load.

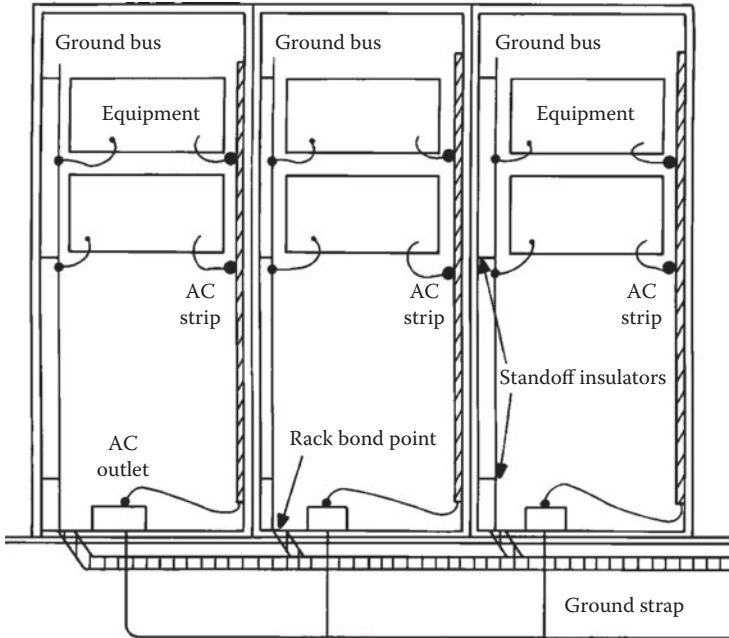
The ac power supply for many buildings originates from a transformer located in a basement utility room. In large buildings, the ac power for each floor can be supplied by transformers closer to the loads they serve. Most transformers are 208 Y/120 V three-phase. Many fluorescent lighting circuits operate at 277 V, supplied by a 408 Y/277 V transformer. Long feeder lines to DP systems and other sensitive loads raise the possibility of voltage fluctuations based on load demand and ground-loop-induced noise.

Figure 20.27 illustrates the preferred method of power distribution in a building. A separate dedicated isolation transformer is located near the DP equipment, providing good voltage regulation and permitting the establishment of an effective single-point star ground in the data processing center. Note that the power-distribution system voltage shown in the figure (480 V) is maintained until the DP step-down isolation transformer. Use of this higher voltage provides more efficient transfer of electricity throughout the plant. At 480 V, the line current is about 43% of the current in a 208 V system for the same conducted power.

There are a number of tradeoffs with regard to facility ac power-system design. An experienced, licensed electrical contractor or registered professional engineer should be consulted during the early stages of any renovation or new construction project.



**Figure 20.27** Preferred power-distribution configuration for a data processing site. (After [6].)



**Figure 20.28** Recommended grounding method for equipment racks. To make assembly of multiple racks easier, position the ground connections and ac receptacles at the same location in all racks.

## 20.4 Grounding Equipment Racks

The installation and wiring of equipment racks must be planned carefully to avoid problems during day-to-day operations. Figure 20.28 shows the recommended approach. Bond adjacent racks together with 3/8- to 1/2-in.-diameter bolts. Clean the contacting surfaces by sanding down to bare metal. Use lockwashers on both ends of the bolts. Bond racks together using at least six bolts per side (three bolts for each vertical rail). After securing the racks, repaint the connection points to prevent corrosion.

Run a ground strap from the *main facility ground point*, and bond the strap to the base of each rack. Spot-weld the strap to a convenient spot on one side of the rear portion of each rack. Secure the strap at the same location for each rack used. A mechanical connection between the rack and the ground strap can be made using bolts and lockwashers, if necessary. Be certain, however, to sand down to bare metal before making the ground connection. Because of the importance of the ground connection, it is recommended that each attachment be made with a combination of crimping and silver-solder. Keep the length of strap between adjacent bolted racks as short as possible by routing the strap directly under the racks.

Install a vertical ground bus in each rack (as illustrated in Figure 20.28). Use about 1-1/2-in.-wide, 1/4-in.-thick copper busbar. Size the busbar to reach from the bottom of the rack to about 1 ft short of the top. The exact size of the busbar is not critical, but it must be sufficiently wide and rigid to permit the drilling of 1/8-in. holes without deforming.

Mount the ground busbar to the rack using insulated standoffs. Porcelain standoffs commonly found in high-voltage equipment are useful for this purpose. Porcelain standoffs are readily available and reasonably priced. Attach the ground busbar to the rack at the point that the facility ground strap attaches to the rack. Silver-solder the busbar to the rack and strap at the same location in each rack used.

Install an orange-type isolated ac receptacle box at the bottom of each rack. The orange-type outlet isolates the green-wire power ground from the receptacle box. Use insulated standoffs to mount the ac outlet box to the rack. The goal of this arrangement is to keep the green-wire ac and facility system grounds separate from the ac distribution conduit and metal portions of the building structure. Try to

route the power conduit and facility ground cable or strap via the same physical path. Keep metallic conduit and building structures insulated from the facility ground line, except at the bulkhead panel (main grounding point). Carefully check the local electrical code before proceeding.

Although the foregoing procedure is optimum from a signal-grounding standpoint, it should be pointed out that under a ground-fault condition, performance of the system can be unpredictable if high currents are being drawn in the current-carrying conductors supplying the load. Vibration of ac circuit elements resulting from the magnetic field effects of high-current-carrying conductors is insignificant as long as all conductors are within the confines of a given raceway or conduit. A ground fault will place return current outside of the normal path. If sufficiently high currents are being conducted, the consequences can be devastating. Sneak currents from ground faults have been known to destroy wiring systems that were installed exactly to code. As always, consult an experienced electrical contractor.

Mount a vertical ac strip inside each rack to power the equipment. Insulate the power strip from the rack using porcelain standoffs or use a strip with an insulated (plastic) housing. Such a device is shown in Figure 20.29. Power equipment from the strip using standard three-prong grounding ac plugs. Do not defeat the safety ground connection. Equipment manufacturers use this ground to drain transient energy. Furthermore, defeating the safety ground will violate local electrical codes.

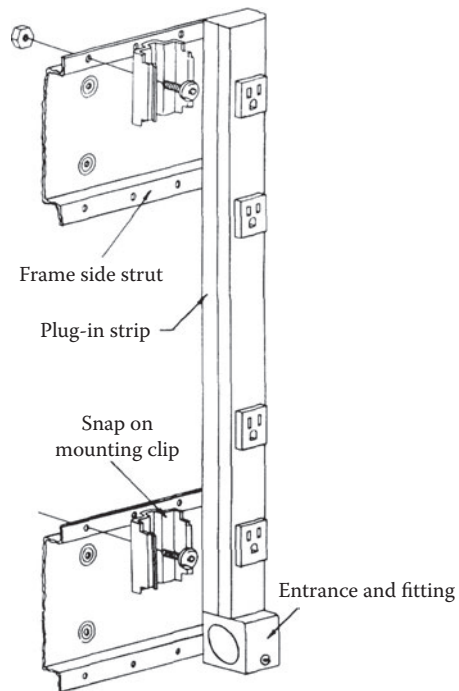
Mount equipment in the rack using normal metal mounting screws. If the location is in a high-RF field, clean the rack rails and equipment-panel connection points to ensure a good electrical bond. This is important because in a high-RF field, detection of RF energy can occur at the junctions between equipment chassis and the rack.

Connect a separate ground wire from each piece of equipment in the rack to the vertical ground busbar. Use no. 12 or larger stranded copper wire (insulated). Connect the ground wire to the busbar by drilling a hole in the busbar at a convenient elevation near the equipment. Fit one end of the ground wire with an enclosed-hole solderless terminal connector (no. 10-sized hole or larger). Attach the ground wire to the busbar using no. 10 (or larger) hardware. Use an internal-tooth lockwasher between the busbar and the nut. Fit the other end of the ground wire with a terminal that will be accepted by the ground terminal at the equipment. If the equipment has an isolated *signal* ground terminal, tie it to the ground busbar, as well.

Whenever servicing equipment in the rack, make certain to disconnect the ac power cord before removing the unit from the rack or disconnecting the rack ground wire. During any service work, make the first step removal of the ac power plug; when reassembling the unit, make the last step reinsertion of the plug. Do not take chances.

Figure 20.30 shows each of the grounding elements discussed in this section integrated into one diagram. This approach fulfills the requirements of personnel safety and equipment performance.

Follow similar grounding rules for simple one-rack equipment installations. Figure 20.31 illustrates the grounding method for a single open-frame equipment rack. The vertical ground bus is supported by insulators, and individual jumpers are connected from the ground rail to each chassis.



**Figure 20.29** Rack mounting detail for an insulated-shell ac power strip.

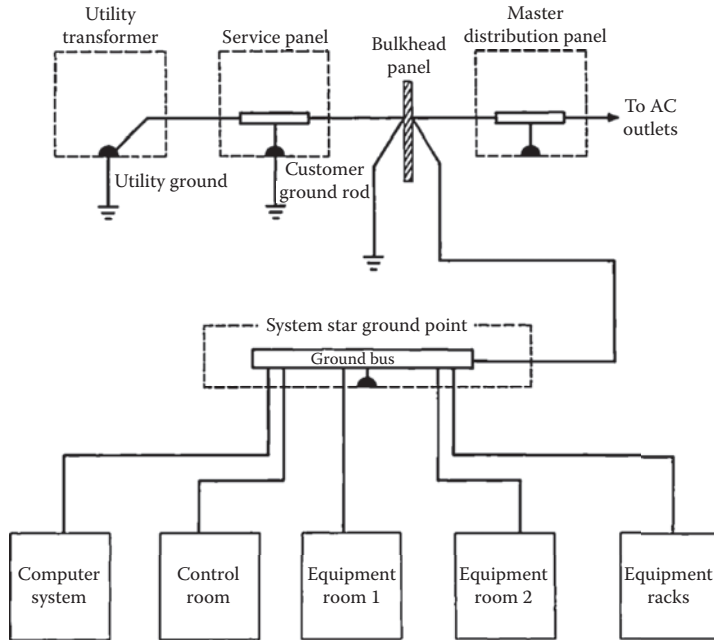


Figure 20.30 Equivalent ground circuit diagram for a medium-sized commercial/industrial facility.

## 20.5 Grounding Signal Cables

Proper ground-system installation is the key to minimizing noise currents on signal-carrying cables. Audio, video, and data lines are often subject to ac power noise currents and RFI. The longer the cable run, the more susceptible it is to disturbances. Unless care is taken in the layout and installation of such cables, unacceptable performance of the overall system can result.

### 20.5.1 Analyzing Noise Currents

Figure 20.32 shows a basic source and load connection. No grounds are present, and both the source and the load float. This is the optimum condition for equipment interconnection. Either the source or the load can be tied to ground with no problems, provided only one ground connection exists. *Unbalanced* systems are created when each piece of equipment has one of its connections tied to ground, as shown in Figure 20.33. This condition occurs if the source and load equipment have unbalanced (single-ended) inputs and outputs. This type of equipment utilizes chassis ground (or common) for one of the conductors. Problems are compounded when the equipment is separated by a significant distance.

As shown in Figure 20.34, a difference in ground potential causes current flow in the ground wire. This current develops a voltage across the wire resistance. The ground-noise voltage adds directly to the signal itself. Because the ground current is usually

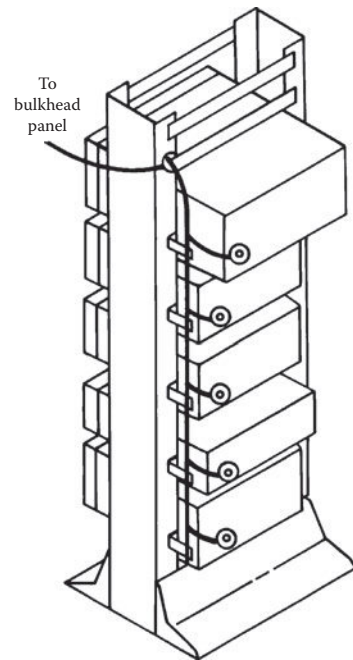
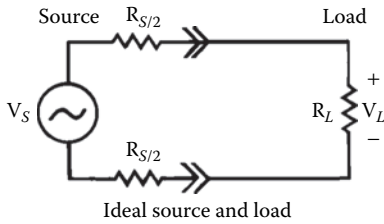
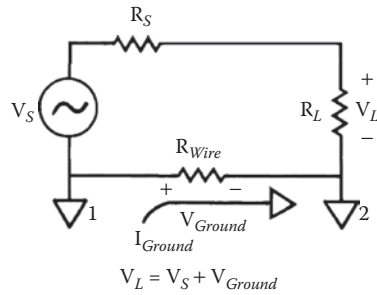


Figure 20.31 Ground bus for an open-frame equipment rack.

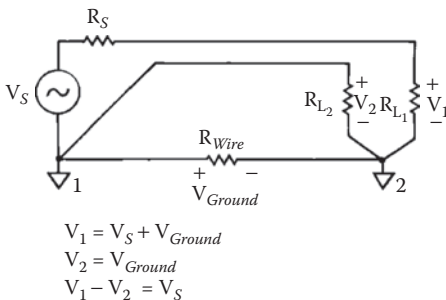




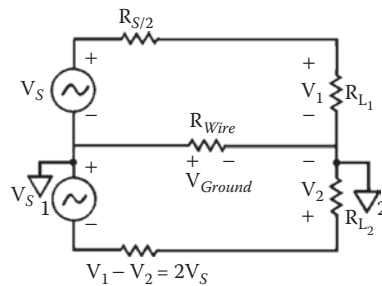
**Figure 20.32** A basic source and load connection. No grounds are indicated, and both the source and the load float.



**Figure 20.33** An unbalanced system in which each piece of equipment has one of its connections tied to ground.



**Figure 20.34** Ground-loop noise can be canceled by amplifying both the high side and the ground side of the source and subtracting the two signals.



**Figure 20.35** A balanced source configuration where the inherent amplitude error of the system shown in Figure 20.34 is eliminated.

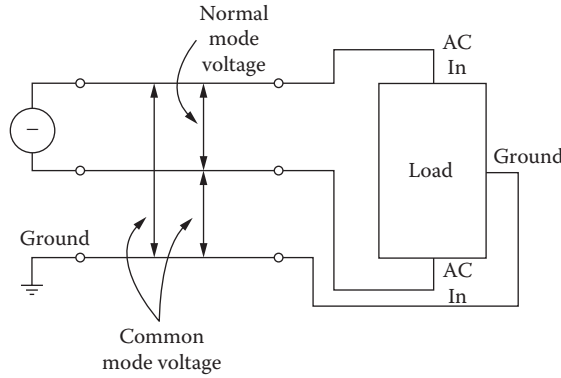
the result of leakage in power transformers and line filters, the 60 Hz signal gives rise to hum of one form or another. Reducing the wire resistance through a heavier ground conductor helps the situation, but cannot eliminate the problem.

By amplifying both the high side and the ground side of the source and subtracting the two to obtain a *difference signal*, it is possible to cancel the ground-loop noise. This is the basis of the *differential input* circuit, illustrated in Figure 20.35. Unfortunately, problems still can exist with the unbalanced-source-to-balanced-load system. The reason centers on the impedance of the unbalanced source. One side of the line will have a slightly lower amplitude because of impedance differences in the output lines. By creating an output signal that is out of phase with the original, a balanced source can be created to eliminate this error. (See Figure 20.35.) As an added benefit, for a given maximum output voltage from the source, the signal voltage is doubled over the unbalanced case.

### 20.5.2 Types of Noise

Two basic types of noise can appear on ac power, audio, video, and computer data lines within a facility: *normal mode* and *common mode*. Each type has a particular effect on sensitive load equipment. The normal-mode voltage is the potential difference that exists between pairs of power (or signal) conductors. This voltage also is referred to as the *transverse-mode* voltage. The common-mode voltage is a potential difference (usually noise) that appears between the power or signal conductors and the local ground reference. The differences between normal-mode and common-mode noise are illustrated in Figure 20.36.





**Figure 20.36** The principles of normal-mode and common-mode noise voltages as they apply to ac power circuits.

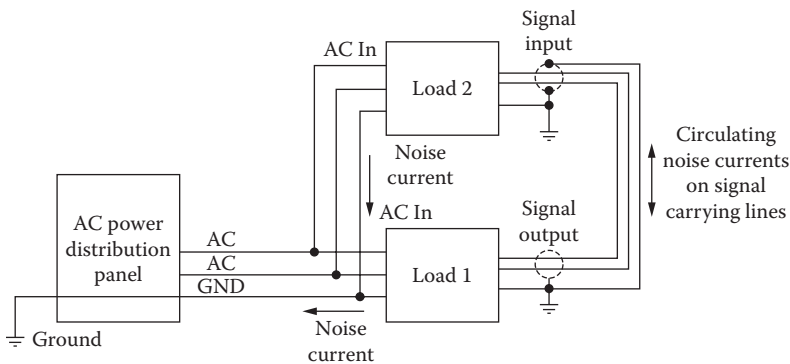
The common-mode noise voltage will change, depending upon what is used as the ground reference point. It is often possible to select a ground reference that has a minimum common-mode voltage with respect to the circuit of interest, particularly if the reference point and the load equipment are connected by a short conductor. Common-mode noise can be caused by electrostatic or electromagnetic induction.

In practice, a single common-mode or normal-mode noise voltage is rarely found. More often than not, load equipment will see both common-mode and normal-mode noise signals. In fact, unless the facility wiring system is unusually well-balanced, the noise signal of one mode will convert some of its energy to the other mode.

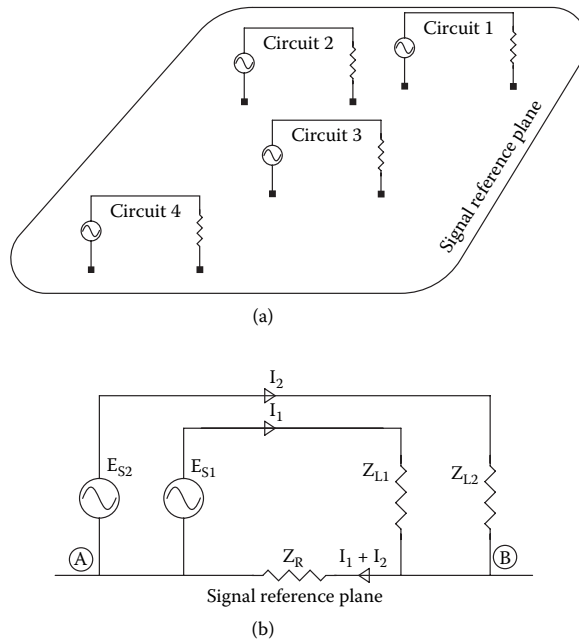
Common-mode and normal-mode noise disturbances typically are caused by momentary impulse voltage differences among parts of a distribution system that have differing ground potential references. If the sections of a system are interconnected by a signal path in which one or more of the conductors are grounded at each end, the ground offset voltage can create a current in the grounded signal conductor. If noise voltages of sufficient potential occur on signal-carrying lines, normal equipment operation can be disrupted. (See Figure 20.37.)

### 20.5.3 Noise Control

Noise control is an important aspect of computer and electronic system design and maintenance [2]. The process of noise control through proper grounding techniques is more correctly called *referencing*. For this discussion, electronic systems can be viewed as a multiplicity of signal sources transmitting signals to a multiplicity of loads. Practically speaking, the impedance of the signal return path is never



**Figure 20.37** An illustration of how noise currents can circulate within a system because of the interconnection of various pieces of hardware.



**Figure 20.38** The equipotential plane: (a) individual signal sources, (b) net effect on the signal reference plane. (From [2]. Used with permission.)

zero, and dedicated return paths for each source-load pair are not always practical. Packaged electronics systems typically incorporate a common signal reference plane that serves as a common return path for numerous source-load pairs. (See Figure 20.38a.) The signal reference plane may be a large dedicated area on a circuit board, the metal chassis or enclosure of the electronic equipment, or the metal frame or mounting rack that houses several different units. Ideally, the signal reference plane offers zero impedance to the signal current. Practically, however, the signal reference plane has a finite impedance. The practical result is illustrated in Figure 20.38b and is called *common-impedance* or *conductive coupling*.

Because a practical signal reference plane has a finite impedance, current flow in the plane will produce potential differences between various points on the plane. Source-load pairs referenced to the plane will, therefore, experience interference as a result.  $Z_R$  is common to both circuits referenced to the plane in Figure 20.38b. Thus,  $I_1$  and  $I_2$  returning to their respective sources will produce interference voltages by flowing through  $Z_R$ . The total interference voltage drop seen across  $Z_R$  causes the source reference A to be at a different potential than the load reference B. This difference in potential is often called *ground voltage shift* (even though ground may not even be involved) and is a major source of noise and interference in electronic circuits.

Ground voltage shifts can also be caused by electromagnetic or electrostatic fields in close proximity to the source-load pairs. The interference source induces interference voltages into any closed loop by antenna action. This loop is called a *ground loop* (even though ground may not be involved). Interference voltages can be minimized by reducing the loop area as much as possible. This can be very difficult if the loop includes an entire room. The interference voltage can be eliminated entirely by breaking the loop.

Within individual electronic equipments, the signal reference plane consists of a metal plate or the metal enclosure or a rack assembly, as previously discussed. Between units of equipment that are located in different rooms, on different floors, or even in different buildings, the signal reference planes of each unit must be connected together via interconnected wiring such as coax shields or separate conductors. This action, of course, increases the impedance between signal reference planes and makes noise control more difficult. Reducing noise caused by common-impedance coupling is a matter of reducing the impedance of the interconnected signal reference planes.

Regardless of the configuration encountered (i.e., circuit board, individual electronic equipment, or equipment remotely located within a facility or in separate buildings), the next question to be answered is, Should the signal reference be connected to ground? Floating signal grounding, single-point grounding, and multipoint grounding are methods of accomplishing this signal-reference-to-ground connection.

IEEE Standard 1100 recommends multipoint grounding for most computers. For effective multipoint grounding, conductors between separate points desired to be at the same reference potential should be less than 0.1 wavelength ( $\lambda/10$ ) of the interference or noise-producing signal. Longer conductor lengths will exhibit significant impedance because of the antenna effect and become ineffective as equalizing conductors between signal references. On printed circuit cards or within individual electronics equipments, short conductor lengths are usually easy to achieve. For remotely located equipments, however, short equalizing conductor lengths may be impossible. Equipment in relatively close proximity can be equalized by cutting bonding conductors to an odd multiple of  $\lambda/2$  at the noise frequency. The distribution of standing waves on bonding conductors is illustrated in Figure 20.39. The impedance,  $Z$ , is minimum for odd multiples of  $\lambda/2$  but maximum for odd multiples of  $\lambda/4$ .

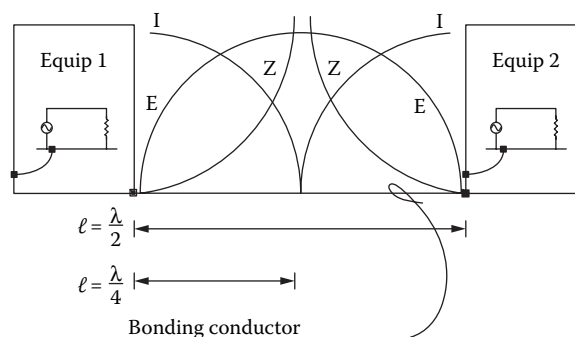
For remotely located electronics equipment within the same room, equalizing potential between respective signal reference systems may have to be accomplished with an equipotential plane. An ideal equipotential signal reference plane is one that has zero volts (thus zero impedance) between any two points on the plane. Because an *ideal* equipotential plane is not attainable, a *nominal* equipotential plane is accepted. Multipoint grounding connections are made to the plane, which insures minimum ground voltage shift between signal reference systems connected to the plane. Collectively, the current flow in an equipotential plane can be quite large. Between any two equipments however, the current flow should be low because of the many current paths available.

Practical versions of an equipotential plane include the following:

- Bolted stringer system of a raised computer-room floor
- Flat copper strips bonded together at 2-ft centers
- Copper conductors bonded together at 2-ft centers
- Single or multiple, flat copper strips connected between equipment

## 20.6 Patch-Bay Grounding

Patch panels for audio, video, and data circuits require careful attention to planning to avoid built-in grounding problems. Because patch panels are designed to tie together separate pieces of equipment, often from remote areas of a facility, the opportunity exists for ground loops. The first rule of patch-bay design is to never use a patch bay to switch low-level (microphone) signals. If mic sources must be patched from one location to another, install a bank of mic-to-line amplifiers to raise the signal levels to 0



**Figure 20.39** Standing waves on a bonding conductor resulting from the antenna effect. (From [2]. Used with permission.)

dBm before connection to the patch bay. Most video output levels are 1 V P-P, giving them a measure of noise immunity. Data levels are typically 5 V. Although these line-level signals are significantly above the noise floor, capacitive loading and series resistance in long cables can reduce voltage levels to a point that noise becomes a problem.

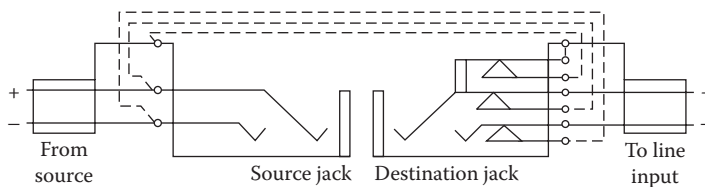
Newer-design patch panels permit switching of ground connections along with signal lines. Figure 20.40 illustrates the preferred method of connecting an audio patch panel into a system. Note that the source and destination jacks are *normalled* to establish ground signal continuity. When another signal is plugged into the destination jack, the ground from the new source is carried to the line input of the destination jack. With such an approach, jack cords that provide continuity between sleeve (ground) points are required.

If only older-style, conventional jacks are available, use the approach shown in Figure 20.41. This configuration will prevent ground loops, but because destination shields are not carried back to the source when normalling, noise will be higher. Bus all destination jack sleeves together, and connect to the local (rack) ground. The wiring methods shown in Figure 20.40 and Figure 20.41 assume balanced input and output lines with all shields terminated at the load (input) end of the equipment.

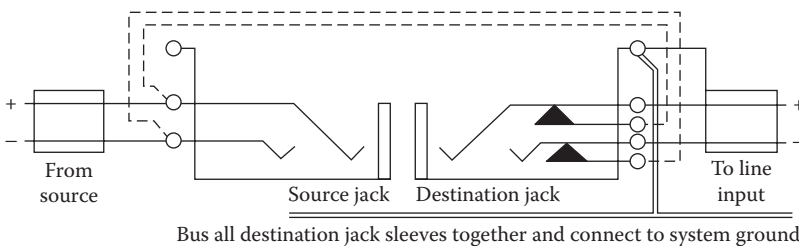
## 20.7 Cable Routing

Good engineering practice dictates that different signal levels be grouped and separated from each other. It is common practice to separate cables into the following groups:

- ac power
- Speaker lines
- Line-level audio
- Microphone-level audio
- Video lines
- Control and data lines



**Figure 20.40** Patch-panel wiring for seven-terminal normalling jack fields. Use patch cords that connect ground (sleeve) at both ends.



**Figure 20.41** Patch-panel wiring for conventional normalling jack fields. Use patch cords that connect ground (sleeve) at both ends.

Always use two-conductor shielded cable for all audio signal cables. This includes both balanced and unbalanced circuits, and microphone-level and line-level cables. On any audio cable connecting two pieces of equipment, tie the shield at one end only. Connect at the receiving end of signal transmission. On video coaxial cables running to outlet jacks mounted on plates, isolate the connector from the plate. The shield should connect to ground only at the equipment input/output or patch panel. For data cables, carefully follow the recommendations of the equipment manufacturer. The preferred interconnection method for long data cables is fiber optics, which eliminates ground-loop problems altogether.

### 20.7.1 Overcoming Ground-System Problems

Although the concept of equipment grounding seems rather basic, it can become a major headache if not done correctly. Even if all of the foregoing guidelines are followed to the letter, there is the possibility of ground loops and objectionable noise on audio, video, or data lines. The larger the physical size of the facility, the greater the potential for problems. An otherwise perfect ground system can be degraded by a single wiring error. An otherwise clean signal ground can be contaminated by a single piece of equipment experiencing a marginal ground fault condition.

If problems are experienced with a system, carefully examine all elements to track down the wiring error or offending load. Do not add ac line filters or signal line filters to correct a problem system. In a properly designed system, even one in a high-RF field, proper grounding and shielding techniques will permit reliable operation. Adding filters merely hides the problem. Instead, correct the problem at its source. In a highly complex system such as a data processing facility, the necessity to interconnect a large number of systems may require the use of fiber-optic transmitters and receivers.

## 20.8 References

---

1. Block, R., "The Grounds for Lightning and EMP Protection," PolyPhaser Corporation, Gardnersville, NV, 1987.
2. DeWitt, W. E., "Facility Grounding Practices," in *The Electronics Handbook*, J. C. Whitaker (Ed.), CRC Press, Boca Raton, FL, pp. 2218–2228, 1996.
3. NFPA Standard 70, "The National Electrical Code," National Fire Protection Association, Quincy, MA, 1993.
4. DeDad, J. A. (Ed.), "ITE Room Grounding and Transient Protection," in *Practical Guide to Power Distribution for Information Technology Equipment*, PRIMEDIA Intertec, Overland Park, KS, pp. 83–84, 1997.
5. DeDad, J. A. (Ed.), "Basic Facility Requirements," in *Practical Guide to Power Distribution for Information Technology Equipment*, PRIMEDIA Intertec, Overland Park, KS, p. 24, 1997.
6. Federal Information Processing Standards Publication No. 94, *Guideline on Electrical Power for ADP Installations*, U.S. Department of Commerce, National Bureau of Standards, Washington, DC, 1983.
7. Gruzs, T. M., "High Availability, Fault-Tolerant AC Power Distribution Systems for Critical Loads," *Proceedings, Power Quality Solutions/Alternative Energy*, Intertec International, Ventura, CA, p. 22, September 1996.

## 20.9 Bibliography

---

- Benson, K. B., and J. C. Whitaker, *Television and Audio Handbook for Engineers and Technicians*, McGraw-Hill, New York, 1989.
- Block, R., "How to Ground Guy Anchors and Install Bulkhead Panels," *Mobile Radio Technology*, PRIMEDIA Intertec, Overland Park, KS, February 1986.
- Davis, G., and R. Jones, *Sound Reinforcement Handbook*, Yamaha Music Corporation, Hal Leonard Publishing, Milwaukee, WI, 1987.

- Fardo, S., and D. Patrick, *Electrical Power Systems Technology*, Prentice-Hall, Englewood Cliffs, NJ, 1985.
- Hill, M., "Computer Power Protection," *Broadcast Engineering*, PRIMEDIA Intertec, Overland Park, KS, April 1987.
- IEEE 142 (Green Book), "Grounding Practices for Electrical Systems," IEEE, New York.
- Lanphere, J., "Establishing a Clean Ground," *Sound & Video Contractor*, PRIMEDIA Intertec, Overland Park, KS., August 1987.
- Lawrie, R., *Electrical Systems for Computer Installations*, McGraw-Hill, New York, 1988.
- Little, R., "Surge Tolerance: How Does Your Site Rate?" *Mobile Radio Technology*, Intertec Publishing, Overland Park, KS, June 1988.
- Midkiff, J., "Choosing the Right Coaxial Cable Hanger," *Mobile Radio Technology*, Intertec Publishing, Overland Park, KS, April 1988.
- Mullinack, H. G., "Grounding for Safety and Performance," *Broadcast Engineering*, PRIMEDIA Intertec, Overland Park, KS, October 1986.
- Sullivan, T., "How to Ground Coaxial Cable Feedlines," *Mobile Radio Technology*, PRIMEDIA Intertec, Overland Park, KS, April 1988.
- Technical Reports LEA-9-1, LEA-0-10, and LEA-1-8, Lightning Elimination Associates, Santa Fe Springs, CA.

# 21

## Standby Power Systems

---

### 21.1 Introduction

---

When utility company power problems are discussed, most people immediately think of blackouts. The lights go out, and everything stops. With the facility down and in the dark, there is nothing to do but sit and wait until the utility company finds the problem and corrects it. This process generally takes only a few minutes. There are times, however, when it can take hours. In some remote locations, it can even take days.

Blackouts are, without a doubt, the most troublesome utility company problem that a facility will have to deal with. Statistics show that power failures are, generally speaking, a rare occurrence in most areas of the country. They are also short in duration. Studies have shown that 50% of blackouts last 6 s or less, and 35% are less than 11 min long. These failure rates usually are not cause for concern to commercial users, except where computer-based operations, transportation control systems, medical facilities, and communications sites are concerned.

When continuity of operation is critical, redundancy must be carried throughout the system. The site never should depend upon one critical path for ac power. For example, if the facility is fed by a single step-down transformer, a lightning flash or other catastrophic event could result in a transformer failure that would bring down the entire site. A replacement could take days or even weeks.

#### 21.1.1 Blackout Effects

A facility that is down for even 5 min can suffer a significant loss of productivity or data that may take hours or days to rebuild. A blackout affecting a transportation or medical center could be life-threatening. Coupled with this threat is the possibility of extended power-service loss due to severe storm conditions. Many broadcast and communications relay sites are located in remote, rural areas or on mountaintops. Neither of these kinds of locations are well-known for their power reliability. It is not uncommon in mountainous areas for utility company service to be out for extended periods after a major storm. Few operators are willing to take such risks with their business. Most choose to install standby power systems at appropriate points in the equipment chain.

The cost of standby power for a facility can be substantial, and an examination of the possible alternatives should be conducted before any decision on equipment is made. Management must clearly define the direct and indirect costs and weigh them appropriately. Include the following items in the cost-vs.-risk analysis:

- Standby power-system equipment purchase and installation cost
- Exposure of the system to utility company power failure
- Alternative operating methods available to the facility
- Direct and indirect costs of lost uptime because of blackout conditions

A distinction must be made between *emergency* and *standby* power sources. Strictly speaking, emergency systems supply circuits legally designated as being essential for safety to life and property. Standby power systems are used to protect a facility against the loss of productivity resulting from a utility company power outage.

## 21.2 Standby Power Options

To ensure the continuity of ac power, many commercial/industrial facilities depend upon either two separate utility services or one utility service plus on-site generation. Because of the growing complexity of electrical systems, attention must be given to power-supply reliability.

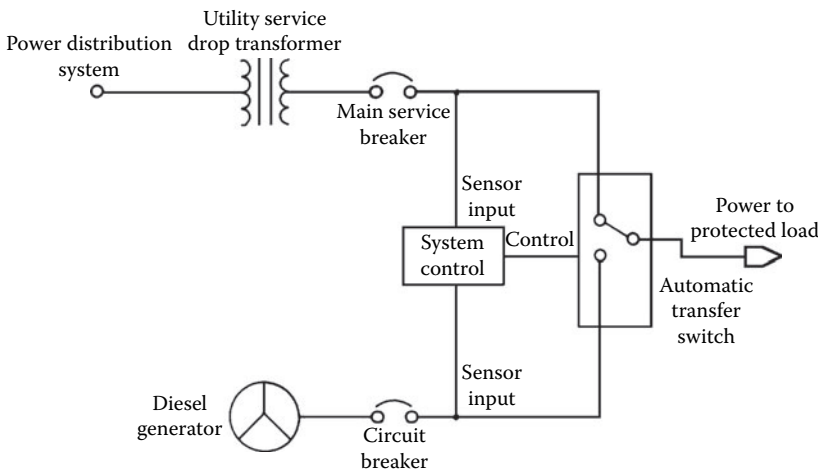
The engine-generator shown in Figure 21.1 is the classic standby power system. An automatic transfer switch monitors the ac voltage coming from the utility company line for power failure conditions. Upon detection of an outage for a predetermined period of time (generally 1 to 10 s), the standby generator is started; after the generator is up to speed, the load is transferred from the utility to the local generator. Upon return of the utility feed, the load is switched back, and the generator is stopped. This basic type of system is used widely in industry and provides economical protection against prolonged power outages (5 min or more).

The transfer device shown in Figure 21.1 is a contactor-type, break-before-make unit. By replacing the simple transfer device shown with an automatic overlap (static) transfer switch, as shown in Figure 21.2, additional functionality can be gained. The overlap transfer switch permits the on-site generator to be synchronized with the load, making a clean switch from one energy source to another. This functionality offers the following benefits:

- Switching back to the utility feed from the generator can be accomplished without interruption in service.
- The load can be cleanly switched from the utility to the generator in anticipation of utility line problems (such as an approaching severe storm).
- The load can be switched to and from the generator to accomplish *load shedding* objectives (discussed later in this chapter).

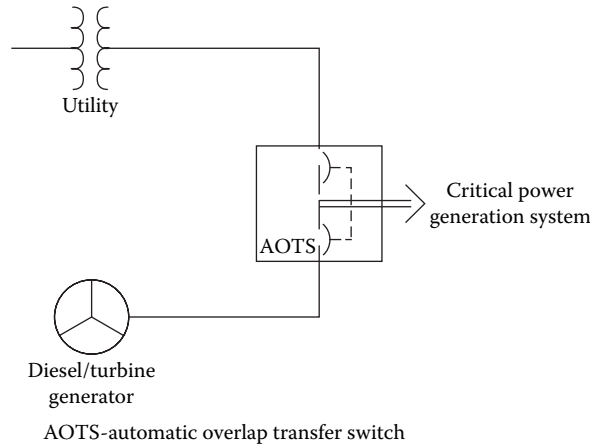
### 21.2.1 Dual-Feeder System

In some areas, usually metropolitan centers, two utility company power drops can be brought into a facility as a means of providing a source of standby power. As shown in Figure 21.3, two separate utility service drops — from separate power-distribution systems — are brought into the plant, and an automatic transfer switch changes the load to the backup line in the event of a main-line failure. The dual-feeder system provides an advantage over the auxiliary diesel arrangement in that power transfer from main to

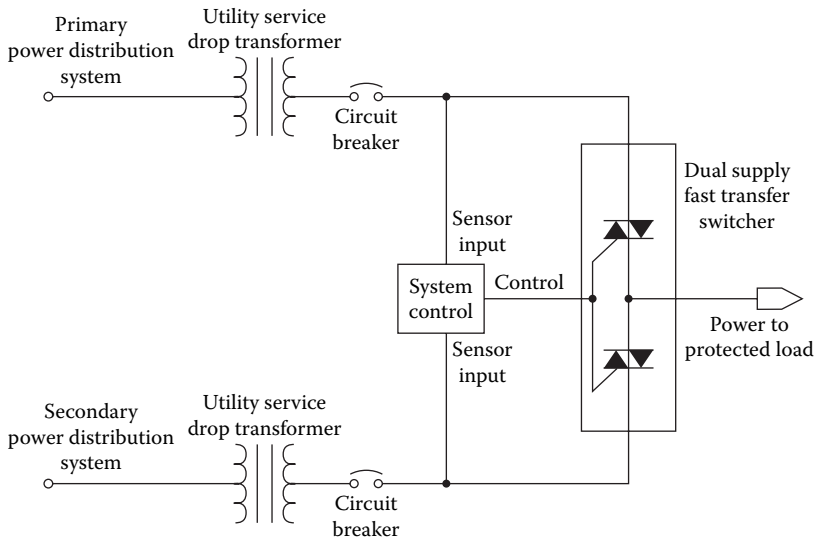


**Figure 21.1** The classic standby power system using an engine-generator set. This system protects a facility from prolonged utility company power failures.





**Figure 21.2** The use of a static transfer switch to transfer the load from the utility company to the on-site generator.



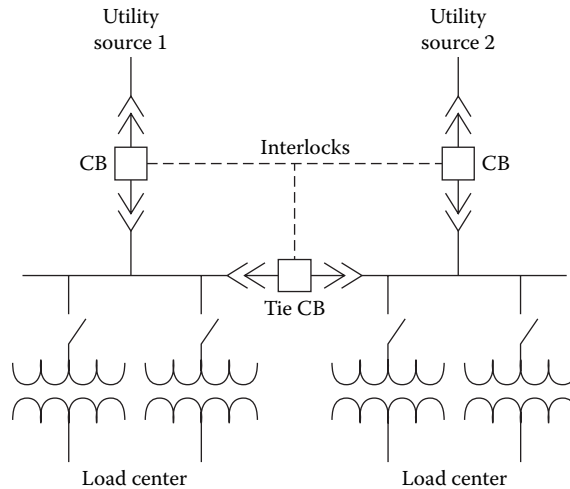
**Figure 21.3** The dual-utility-feeder system of ac power loss protection. An automatic transfer switch changes the load from the main utility line to the standby line in the event of a power interruption.

standby can be made in a fraction of a second if a static transfer switch is used. Time delays are involved in the diesel generator system that limit its usefulness to power failures lasting more than several minutes.

The dual-feeder system of protection is based on the assumption that each of the service drops brought into the facility is routed via different paths. This being the case, the likelihood of a failure on both power lines simultaneously is remote. The dual-feeder system will not, however, protect against areawide power failures, which can occur from time to time.

The dual-feeder system is limited primarily to urban areas. Rural or mountainous regions generally are not equipped for dual redundant utility company operation. Even in urban areas, the cost of bringing a second power line into a facility can be high, particularly if special lines must be installed for the feed. If two separate utility services are available at or near the site, redundant feeds generally will be less expensive than engine-driven generators of equivalent capacity.

Figure 21.4 illustrates a dual-feeder system that utilizes both utility inputs simultaneously at the facility. Notice that during normal operation, both ac lines feed loads, and the “tie” circuit breaker is

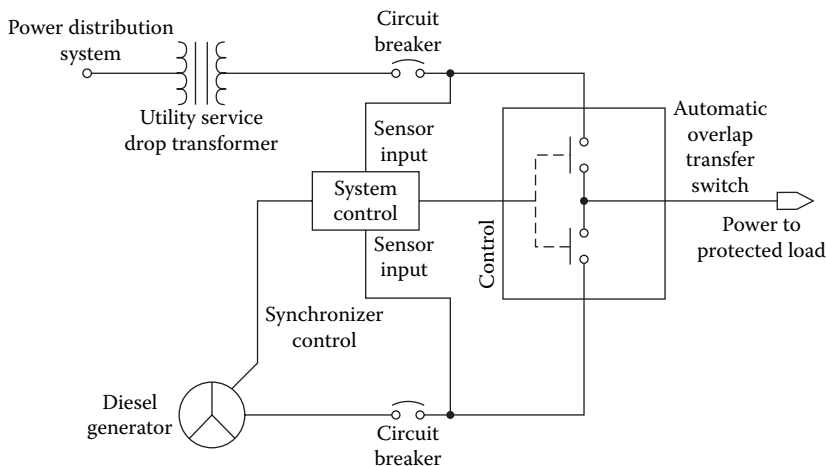


**Figure 21.4** A dual-utility-feeder system with interlocked circuit breakers.

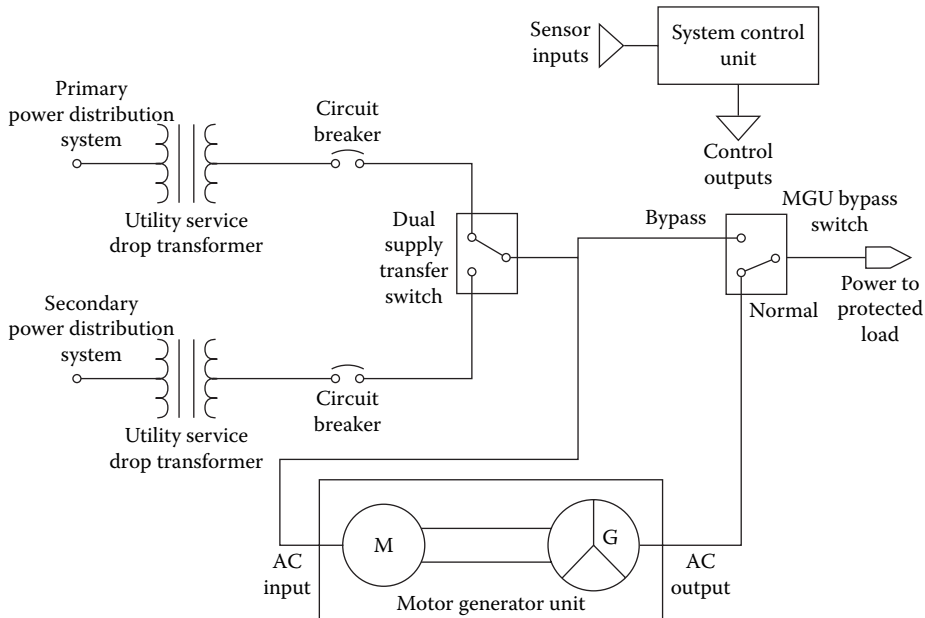
open. In the event of a loss of either line, the circuit-breaker switches reconfigure the load to place the entire facility on the single remaining ac feed. Switching is performed automatically; manual control is provided in the event of a planned shutdown on one of the lines.

### 21.2.2 Peak Power Shaving

Figure 21.5 illustrates the use of a backup diesel generator for both standby power and *peak power shaving* applications. Commercial power customers often can realize substantial savings on utility company bills by reducing their energy demand during certain hours of the day. An automatic overlap transfer switch is used to change the load from the utility company system to the local diesel generator. The changeover is accomplished by a static transfer switch that does not disturb the operation of load equipment. This application of a standby generator can provide financial return to the facility, whether or not the unit is ever needed to carry the load through a commercial power failure.



**Figure 21.5** The use of a diesel generator for standby power and peak power shaving applications. The automatic overlap (static) transfer switch changes the load from the utility feed to the generator instantly so that no disruption of normal operation is encountered.



**Figure 21.6** A dual feeder standby power system using a motor-generator set to provide power fail ride-through and transient-disturbance protection. Switching circuits allow the m-g set to be bypassed, if necessary.

### 21.2.3 Advanced System Protection

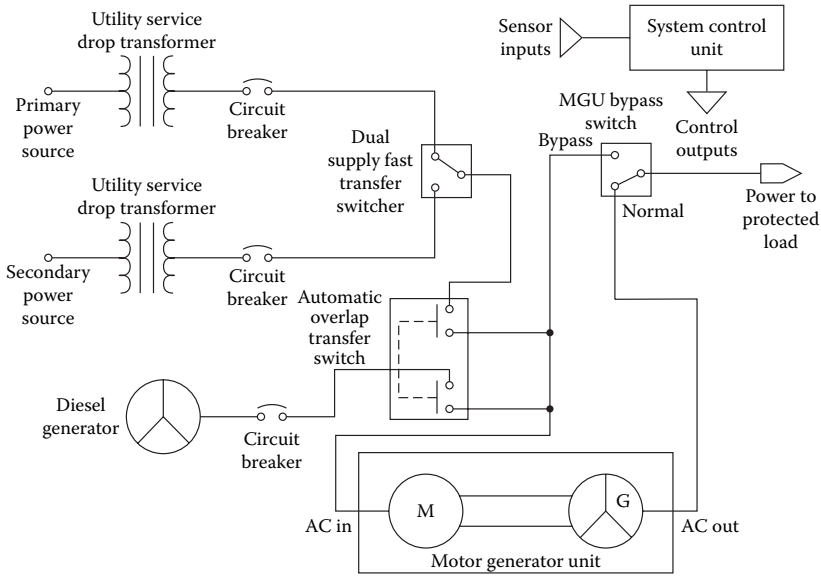
A more sophisticated power-control system is shown in Figure 21.6, where a dual feeder supply is coupled with a motor-generator set to provide clean, undisturbed ac power to the load. The m-g set will smooth over the transition from the main utility feed to the standby, often making a commercial power failure unnoticed by on-site personnel. A conventional m-g set typically will give up to 0.5 s of power fail ride-through, more than enough to accomplish a transfer from one utility feed to the other. This standby power system is further refined in the application illustrated in Figure 21.7, where a diesel generator has been added to the system. With the automatic overlap transfer switch shown at the generator output, this arrangement also can be used for peak demand power shaving.

Figure 21.8 shows a simplified schematic diagram of a 220 kW UPS system utilizing dual utility company feed lines, a 750 kVA gas-engine generator, and five dc-driven motor-generator sets with a 20-min battery supply at full load. The five m-g sets operate in parallel. Each is rated for 100 kW output. Only three are needed to power the load, but four are on-line at any given time. The fifth machine provides redundancy in the event of a failure or for scheduled maintenance work. The batteries are always on-line under a slight charge across the 270 V dc bus. Two separate natural-gas lines, buried along different land routes, supply the gas engine. Local gas storage capacity also is provided.

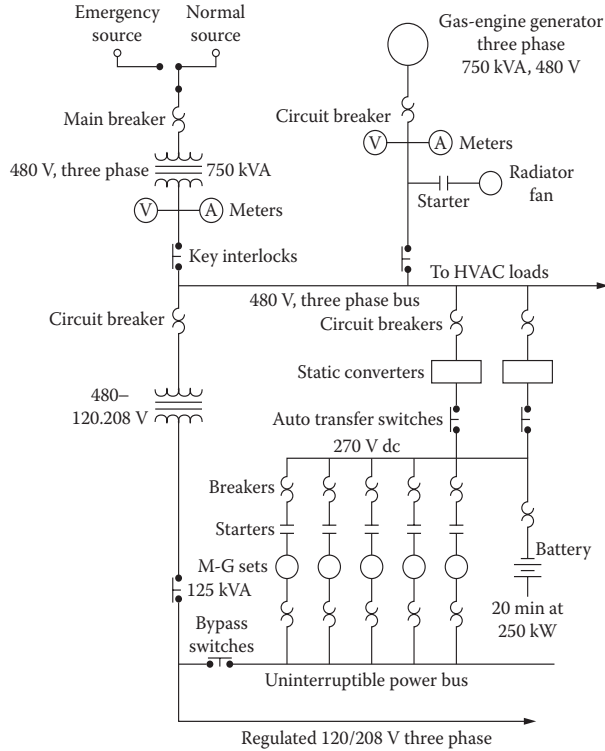
### 21.2.4 Choosing a Generator

Engine-generator sets are available for power levels ranging from less than 1 kVA to several thousand kVA or more. Machines also can be paralleled to provide greater capacity. Engine-generator sets typically are classified by the type of power plant used:

- Diesel. Advantages: rugged and dependable, low fuel costs, low fire or explosion hazard. Disadvantages: somewhat more costly than other engines, heavier in smaller sizes.
- Natural and liquefied petroleum gas. Advantages: quick starting after long shutdown periods, long life, low maintenance. Disadvantage: availability of natural gas during areawide power failure subject to question.



**Figure 21.7** A premium power-supply backup and conditioning system using dual utility company feeds, a diesel generator, and a motor-generator set. An arrangement such as this would be used for critical loads that require a steady supply of clean ac.



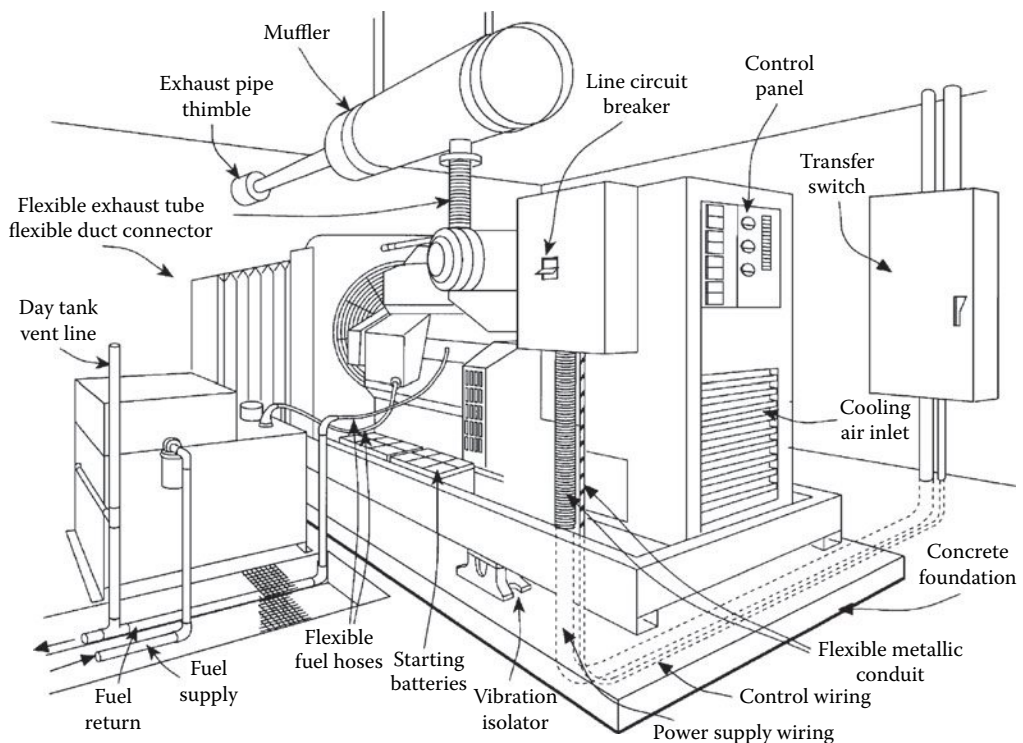
**Figure 21.8** Simplified installation diagram of a high-reliability power system incorporating dual utility feeds, a standby gas-engine generator, and five battery-backed dc m-g sets. (After [1].)

- Gasoline. Advantages: rapid starting, low initial cost. Disadvantages: greater hazard associated with storing and handling gasoline, generally shorter mean time between overhaul.
- Gas turbine. Advantages: smaller and lighter than piston engines of comparable horsepower, rooftop installations practical, rapid response to load changes. Disadvantages: longer time required to start and reach operating speed, sensitive to high input air temperature.

The type of power plant chosen usually is determined primarily by the environment in which the system will be operated and by the cost of ownership. For example, a standby generator located in an urban area office complex may be best suited to the use of an engine powered by natural gas, because of the problems inherent in storing large amounts of fuel. State or local building codes can place expensive restrictions on fuel-storage tanks and make the use of a gasoline- or diesel-powered engine impractical. The use of propane usually is restricted to rural areas. The availability of propane during periods of bad weather (when most power failures occur) also must be considered.

The generator rating for a standby power system should be chosen carefully and should take into consideration the anticipated future growth of the plant. It is good practice to install a standby power system rated for at least 25% greater output than the current peak facility load. This headroom gives a margin of safety for the standby equipment and allows for future expansion of the facility without overloading the system.

An engine-driven standby generator typically incorporates automatic starting controls, a battery charger, and automatic transfer switch. (See Figure 21.9.) Control circuits monitor the utility supply and start the engine when there is a failure or a sustained voltage drop on the ac supply. The switch transfers the load as soon as the generator reaches operating voltage and frequency. Upon restoration of the utility supply, the switch returns the load and initiates engine shutdown. The automatic transfer switch must meet demanding requirements, including:



**Figure 21.9** Typical configuration of an engine-generator set. (From [2]. Used with permission.)

- Carrying the full rated current continuously
- Withstanding fault currents without contact separation
- Handling high inrush currents
- Withstanding many interruptions at full load without damage

The nature of most power outages requires a sophisticated monitoring system for the engine-generator set. Most power failures occur during periods of bad weather. Most standby generators are unattended. More often than not, the standby system will start, run, and shut down without any human intervention or supervision. For reliable operation, the monitoring system must check the status of the machine continually to ensure that all parameters are within normal limits. Time-delay periods usually are provided by the controller that require an outage to last from 5 to 10 s before the generator is started and the load is transferred. This prevents false starts that needlessly exercise the system. A time delay of 5 to 30 min usually is allowed between the restoration of utility power and return of the load. This delay permits the utility ac lines to stabilize before the load is reapplied.

The transfer of motor loads may require special consideration, depending upon the size and type of motors used at a plant. If the residual voltage of the motor is out of phase with the power source to which the motor is being transferred, serious damage can result to the motor. Excessive current draw also may trip overcurrent protective devices. Motors above 50 hp with relatively high load inertia in relation to torque requirements, such as flywheels and fans, may require special controls. Restart time delays are a common solution.

Automatic starting and synchronizing controls are used for multiple-engine-generator installations. The output of two or three smaller units can be combined to feed the load. This capability offers additional protection for the facility in the event of a failure in any one machine. As the load at the facility increases, additional engine-generator systems can be installed on the standby power bus.

#### 21.2.4.1 Generator Types

Generators for standby power applications can be induction or synchronous machines. Most engine-generator systems in use today are of the synchronous type because of the versatility, reliability, and capability of operating independently that this approach provides [2]. Most modern synchronous generators are of the *revolving field alternator* design. Essentially, this means that the armature windings are held stationary and the field is rotated. Therefore, generated power can be taken directly from the stationary armature windings. Revolving armature alternators are less popular because the generated output power must be derived via slip rings and brushes.

The exact value of the ac voltage produced by a synchronous machine is controlled by varying the current in the dc field windings, whereas frequency is controlled by the speed of rotation. Power output is controlled by the torque applied to the generator shaft by the driving engine. In this manner, the synchronous generator offers precise control over the power it can produce.

Practically all modern synchronous generators use a brushless exciter. The exciter is a small ac generator on the main shaft; the ac voltage produced is rectified by a three-phase rotating rectifier assembly also on the shaft. The dc voltage thus obtained is applied to the main generator field, which is also on the main shaft. A voltage regulator is provided to control the exciter field current, and in this manner, the field voltage can be precisely controlled, resulting in a stable output voltage.

The frequency of the ac current produced is dependent on two factors: the number of poles built into the machine, and the speed of rotation (rpm). Because the output frequency must normally be maintained within strict limits (60 or 50 Hz), control of the generator speed is essential. This is accomplished by providing precise rpm control of the *prime mover*, which is performed by a governor.

There are many types of governors; however, for auxiliary power applications, the *isochronous governor* is normally selected. The isochronous governor controls the speed of the engine so that it remains constant from no-load to full load, assuring a constant ac power output frequency from the generator. A modern system consists of two primary components: an electronic speed control and an actuator that adjusts the speed of the engine. The electronic speed control senses the speed of the machine and

provides a feedback signal to the mechanical/hydraulic actuator, which in turn positions the engine throttle or fuel control to maintain accurate engine rpm.

The National Electrical Code provides guidance for safe and proper installation of on-site engine-generator systems. Local codes may vary and must be reviewed during early design stages.

### 21.2.5 UPS Systems

An uninterruptible power system is an elegant solution to power outage concerns. The output of the UPS inverter can be a sine wave or pseudosine wave. When shopping for a UPS system, consider the following:

- Power reserve capacity for future growth of the facility.
- Inverter current surge capability (if the system will be driving inductive loads, such as motors).
- Output voltage and frequency stability over time and with varying loads.
- Required battery supply voltage and current. Battery costs vary greatly, depending upon the type of units needed.
- Type of UPS system (forward-transfer type or reverse-transfer type) required by the particular application. Some sensitive loads may not tolerate even brief interruptions of the ac power source.
- Inverter efficiency at typical load levels. Some inverters have good efficiency ratings when loaded at 90% of capacity, but poor efficiency when lightly loaded.
- Size and environmental requirements of the UPS system. High-power UPS equipment requires a large amount of space for the inverter/control equipment and batteries. Battery banks often require special ventilation and ambient temperature control.

### 21.2.6 Standby Power-System Noise

Noise produced by backup power systems can be a serious problem if not addressed properly. Standby generators, motor-generator sets, and UPS systems produce noise that can disturb building occupants and irritate neighbors or landlords.

The noise associated with electrical generation usually is related to the drive mechanism, most commonly an internal combustion engine. The amplitude of the noise produced is directly related to the size of the engine-generator set. First, consider whether noise reduction is a necessity. Many building owners have elected to tolerate the noise produced by a standby power generator because its use is limited to emergency situations. During a crisis, when the normal source of power is unavailable, most people will tolerate noise associated with a standby generator.

If the decision is made that building occupants can live with the noise of the generator, care must be taken in scheduling the required testing and exercising of the unit. Whether testing occurs monthly or weekly, it should be done on a regular schedule.

If it has been determined that the noise should be controlled, or at least minimized, the easiest way to achieve this objective is to physically separate the machine from occupied areas. This may be easier said than done. Because engine noise is predominantly low-frequency in character, walls and floor/ceiling construction used to contain the noise must be massive. Lightweight construction, even though it may involve several layers of resiliently mounted drywall, is ineffective in reducing low-frequency noise. Exhaust noise is a major component of engine noise but, fortunately, it is easier to control. When selecting an engine-generator set, select the highest-quality exhaust muffler available. Such units often are identified as *hospital-grade* mufflers.

Engine-generator sets also produce significant vibration. The machine should be mounted securely to a slab-on-grade or an isolated basement floor, or it should be installed on vibration isolation mounts. Such mounts usually are specified by the manufacturer.

Because a UPS system or motor-generator set is a source of continuous power, it must run continuously. Noise must be adequately controlled. Physical separation is the easiest and most effective method of shielding occupied areas from noise. Enclosure of UPS equipment usually is required, but noise control is significantly easier than for an engine-generator because of the lower noise levels involved.



Nevertheless, the low-frequency 120 Hz fundamental of a UPS system is difficult to contain adequately; massive constructions may be necessary. Vibration control also is required for most UPS and m-g gear.

### 21.2.7 Batteries

Batteries are the lifeblood of most UPS systems. Important characteristics include the following:

- Charge capacity — how long the battery will operate the UPS
- Weight
- Charging characteristics
- Durability/ruggedness

Additional features that add to the utility of the battery include:

- Built-in status/temperature/charge indicator or data output port
- Built-in overtemperature/overcurrent protection with auto-reset capabilities
- Environmental friendliness

The last point deserves some attention. Many battery types must be recycled or disposed of through some prescribed means. Proper disposal of a battery at the end of its useful life is, thus, an important consideration. Be sure to check the original packaging for disposal instructions. Failure to follow the proper procedures could have serious consequences.

Research has brought about a number of different battery chemistries, each offering distinct advantages. Today's most common and promising rechargeable chemistries include the following:

- *Nickel cadmium* (NiCd) — used for portable radios, cellular phones, video cameras, laptop computers, and power tools. NiCds have good load characteristics, are economically priced, and are simple to use.
- *Lithium ion* (Li-Ion) — typically used for video cameras and laptop computers. This battery has replaced some NiCds for high energy-density applications.
- *Sealed lead-acid* (SLA) — used for uninterruptible power systems, video cameras, and other demanding applications where the energy-to-weight ratio is not critical and low battery cost is desirable.
- *Lithium polymer* (Li-Polymer) — when commercially available, this battery will have the highest energy density and lowest self-discharge of common battery types, but its load characteristics will likely only suit low-current applications.
- *Reusable alkaline* — used for light-duty applications. Because of its low self-discharge, this battery is suitable for portable entertainment devices and other noncritical appliances that are used occasionally.

No single battery offers all the answers; rather, each chemistry is based on a number of compromises.

A battery, of course, is only as good as its charger. Common attributes for the current generation of charging systems include quick-charge capability and automatic battery condition analysis and subsequent *intelligent* charging.

#### 21.2.7.1 Terms

The following terms are commonly used to specify and characterize batteries:

- **Energy density.** The storage capacity of a battery measured in *watt-hours per kilogram* (Wh/kg).
- **Cycle life.** The typical number of charge-discharge cycles for a given battery before the capacity decreases from the nominal 100% to approximately 80%, depending upon the application.
- **Fast-charge time.** The time required to fully charge an empty battery.
- **Self-discharge.** The discharge rate when the battery is not in use.
- **Cell voltage.** The output voltage of the basic battery element. The cell voltage multiplied by the number of cells provides the battery terminal voltage.



- **Load current.** The maximum recommended current the battery can provide.
- **Current rate.** The C-rate is a unit by which charge and discharge times are scaled. If discharged at 1C, a 100 Ah battery provides a current of 100 A; if discharged at 0.5C, the available current is 50 A.
- **Exercise requirement.** This parameter indicates the frequency that the battery needs to be exercised to achieve maximum service life.

### 21.2.7.2 Sealed Lead-Acid Battery

The lead-acid battery is a commonly used chemistry. The *flooded* version is found in automobiles and large UPS battery banks. Most smaller, portable systems use the *sealed* version, also referred to as *gelcell* or SLA.

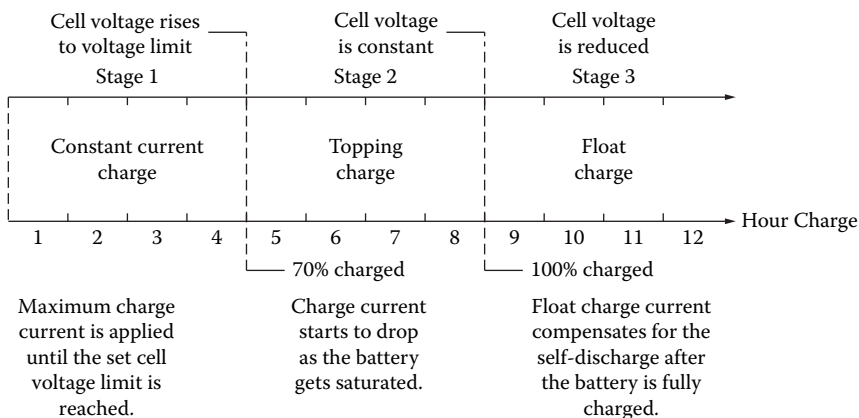
The lead-acid chemistry is commonly used when high power is required, weight is not critical, and cost must be kept low [3]. The typical current range of a medium-sized SLA device is 2 Ah to 50 Ah. Because of its minimal maintenance requirements and predictable storage characteristics, the SLA has found wide acceptance in the UPS industry, especially for *point-of-application* systems.

The SLA is not subject to memory. No harm is done by leaving the battery on float charge for a prolonged time. On the negative side, the SLA does not lend itself well to fast charging. Typical charge times are 8 to 16 hours. The SLA must always be stored in a charged state because a discharged SLA will sulphate. If left discharged, a recharge may be difficult or even impossible.

Unlike the common NiCd, the SLA prefers a shallow discharge. A full discharge reduces the number of times the battery can be recharged, similar to a mechanical device that wears down when placed under stress. In fact, each discharge-charge cycle reduces (slightly) the storage capacity of the battery. This wear-down characteristic also applies to other chemistries, including the NiMH.

The charge algorithm of the SLA differs from that of other batteries in that a *voltage-limit* rather than *current-limit* is used. Typically, a multistage charger applies three charge stages consisting of a *constant-current charge*, *topping-charge*, and *float-charge*. (See Figure 21.10.) During the constant-current stage, the battery charges to 70% in about 5 hours; the remaining 30% is completed by the topping-charge. The slow topping-charge, lasting another 5 hours, is essential for the performance of the battery. If not provided, the SLA eventually loses the ability to accept a full charge, and the storage capacity of the battery is reduced. The third stage is the float-charge that compensates for self-discharge after the battery has been fully charged.

During the constant-current charge, the SLA battery is charged at a high current, limited by the charger itself. After the voltage limit is reached, the topping charge begins and the current starts to gradually decrease. Full-charge is reached when the current drops to a preset level or reaches a low-end plateau.



**Figure 21.10** The charge states of an SLA battery. (From [3]. Used with permission.)

**Table 21.1** Recommended Charge Voltage Limit for the SLA Battery (After [3].)

	2.30 to 2.35 V/cell	2.40 to 2.45 V/cell
Advantage	Maximum service life; battery remains cool on charge; battery can be charged at ambient temperature exceeding 30°C (86°F).	Faster charge times; higher and more consistent capacity readings; less subject to damage because of undercharge condition.
Disadvantage	Slow charge time; capacity readings may be low and inconsistent. Produces undercharge condition that can cause sulphation and capacity loss if the battery is not periodically cycled.	Battery life may be reduced because of elevated battery temperature while charging. A hot battery may fail to reach the cell voltage limit, causing harmful overcharge.

The proper setting of the cell voltage limit is critical and is related to the conditions under which the battery is charged. A typical voltage limit range is from 2.30 to 2.45 V. If a slow charge is acceptable, or if the room temperature can exceed 30°C (86°F), the recommended voltage limit is 2.35 V/cell. If a faster charge is required and the room temperature remains below 30°C, 2.40 or 2.45 V/cell can be used. Table 21.1 compares the advantages and disadvantages of the different voltage settings.

### 21.3 References

1. Lawrie, R., *Electrical Systems for Computer Installations*, McGraw-Hill, New York, 1988.
2. DeDad, J. A., "Auxiliary Power," in *Practical Guide to Power Distribution for Information Technology Equipment*, PRIMEDIA Intertec, Overland Park, KS, pp. 31–39, 1997.
3. Buchmann, I., "Batteries," in *The Electronics Handbook*, J. C. Whitaker (Ed.), p. 1058, CRC Press, Boca Raton, FL, 1996.

### 21.4 Bibliography

- Angevine, E., "Controlling Generator and UPS Noise," *Broadcast Engineering*, PRIMEDIA Intertec, Overland Park, KS, March 1989.
- Baietto, R., "How to Calculate the Proper Size of UPS Devices," *Microservice Management*, PRIMEDIA Intertec, Overland Park, KS, March 1989.
- Federal Information Processing Standards Publication No. 94, *Guideline on Electrical Power for ADP Installations*, U.S. Department of Commerce, National Bureau of Standards, Washington, DC, 1983.
- Smith, M., "Planning for Standby AC Power," *Broadcast Engineering*, PRIMEDIA Intertec, Overland Park, KS, March 1989.

# 22

## Designing for Fault-Tolerance

---

### 22.1 Introduction

---

To achieve high levels of power-system reliability — with the ultimate goal being 24-hour-per-day availability, 365 days per year — some form of power-system redundancy is required, regardless of how reliable the individual power-system components may be [1]. Redundancy, if properly implemented, also provides power-distribution flexibility. By providing more than one path for power flow to the load, the key elements of a system can be shifted from one device or branch to another as required for load balancing, system renovations or alterations, or equipment failure isolation. Redundancy also provides a level of fault tolerance. Fault tolerance can be divided into three basic categories:

- Rapid recovery from failures
- Protection against “slow” power system failures, where there is enough warning of the condition to allow intervention
- Protection against “fast” power system failures, where no warning of the power failure is given

As with many corrective and preventive measures, the increasing costs must be weighed against the benefits.

For example, recent developments in large UPS system technologies have provided the capability to operate two independent UPS systems in parallel, either momentarily or continuously. The ability to momentarily connect two UPS systems allows critical loads to be transferred from one UPS system to the other without placing the UPS systems in bypass, thereby maintaining continuous UPS protection of the loads. Continuous paralleling of the two UPS systems, on the other hand, can be used to create a single redundant UPS system from two otherwise nonredundant systems when multiple UPS modules are out of service (because of failures or maintenance). [Figure 22.1](#) illustrates one such implementation.

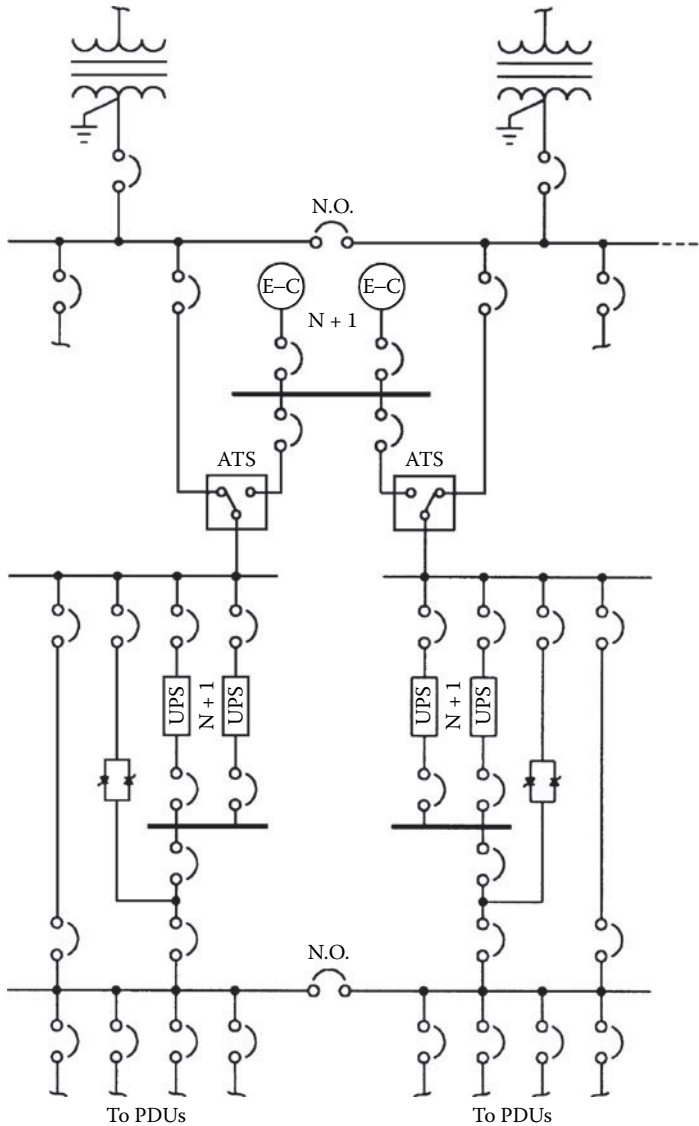
### 22.2 Critical System Bus

---

Many facilities do not require the operation of all equipment during a power outage. Rather than use one large standby power system, key pieces of equipment can be protected with small, dedicated, uninterruptible power systems. Small UPS units are available with built-in battery supplies for computer systems and other hardware. If cost prohibits the installation of a systemwide standby power supply (using generator or solid-state UPS technologies), consider establishing a *critical load bus* that is connected to a UPS system or generator via an automatic transfer switch. This separate power supply is used to provide ac to critical loads, thus keeping the protected systems up and running. The concept is illustrated in [Figure 22.2](#). Unnecessary loads are dropped in the event of a power failure.

A standby system built on the critical load principle can be a cost-effective answer to the power-failure threat. The first step in implementing a critical load bus is to accurately determine the power requirements for the most important equipment. Typical power consumption figures can be found in most equipment instruction manuals. If the data is not listed or available from the manufacturer, it can be measured using a wattmeter.

When planning a critical load bus, be certain to identify accurately which loads are critical and which can be dropped in the event of a commercial power failure. If air-conditioning is interrupted but the



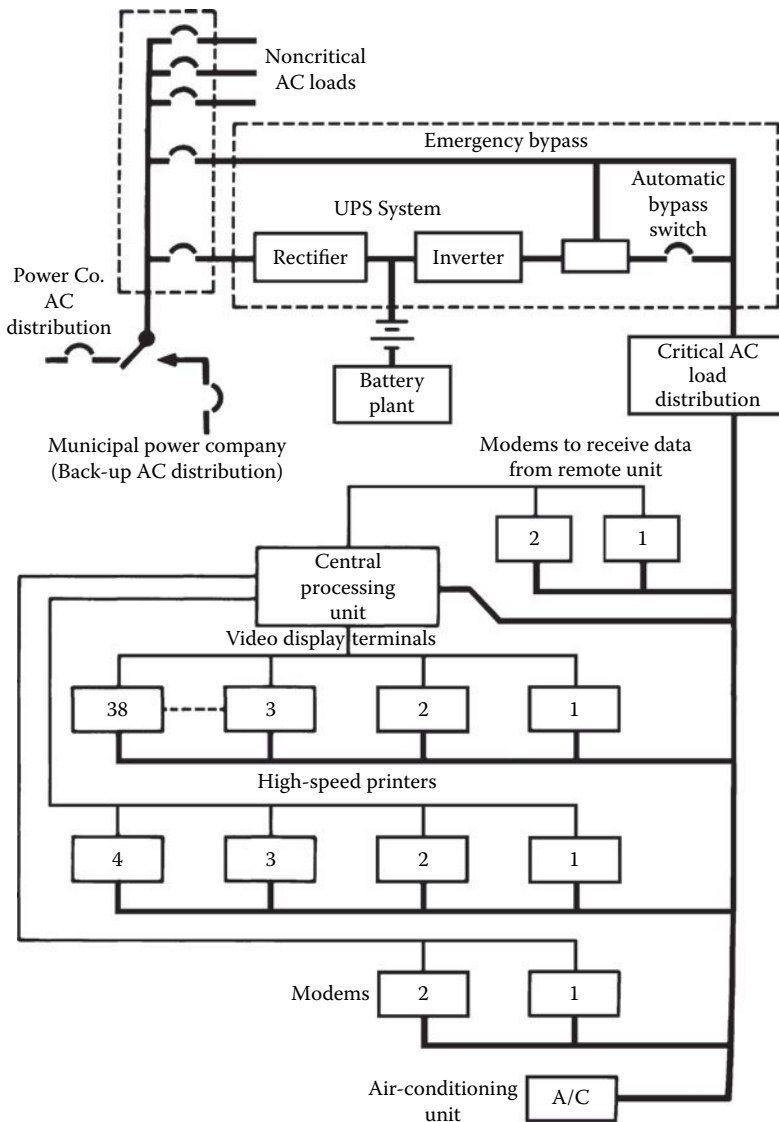
**Figure 22.1** Power-distribution system featuring redundancy and high reliability. Of particular interest is the ability to parallel UPS systems as required by operational conditions. (After [1].)

computer equipment at a large data processing center continues to run, temperatures will rise quickly to the point at which system components may be damaged or the hardware automatically shuts down. It may not be necessary to require cooling fans, chillers, and heat-exchange pumps to run without interruption. However, any outage should be less than 1 to 2 min in duration. Air-cooled computer systems can usually tolerate 5 to 10 min of cooling interruption.

### 22.2.1 Power-Distribution Options

There are essentially 12 building blocks that form what can be described as an assured, reliable, clean power source for computer systems, peripherals, and other critical loads [2]. They are:

- Utility and service entry (step-down transformer, main disconnect, and panelboard, switchboard, or switchgear)



**Figure 22.2** An application of the critical-load power bus concept. In the event of a power failure, all equipment necessary for continued operation is powered by the UPS equipment. Noncritical loads are dropped until commercial ac returns.

- Lightning protection
- Power bus
- Facility power distribution
- Grounding
- Power conditioning equipment
- Critical load air-conditioning
- Frequency converter (if required)
- Batteries for dc backup power
- Emergency engine-generator
- Critical load power-distribution network
- Emergency readiness planning

A power system to support a critical load cannot be said to be reliable unless all these components are operating as intended, not only during normal operation, but especially during an emergency.

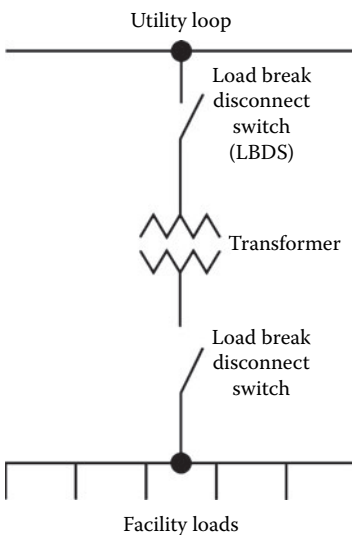
It is easy to become complacent during periods when everything is functioning properly, because this is the usual mode of operation. An absence of contingency plans for dealing with an emergency situation, and a lack of understanding of how the entire system works, thus, can lead to catastrophic shut-downs when an emergency situation arises. Proper training, and periodic reinforcing, is an essential component of a reliable system.

### 22.2.2 Plant Configuration

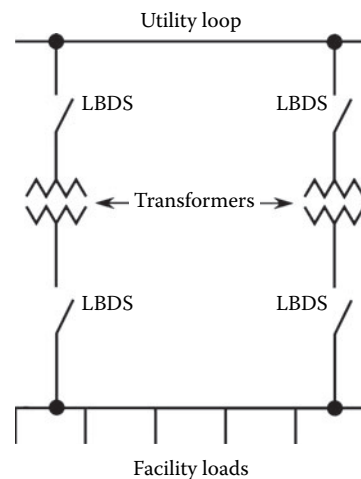
There are any number of hardware configurations that will provide redundancy and reliability for a critical load. Each situation is unique and requires an individual assessment of the options and — more importantly — the risks. The realities of economics dictate that cost is always a factor. Through proper design, however, the expense usually can be held within an acceptable range.

*Design for reliability* begins at the utility service entrance [2]. The common arrangement shown in Figure 22.3 is vulnerable to interruptions from faults at the transformer and associated switching devices in the circuit. Furthermore, service entrance maintenance would require a plant shutdown. In Figure 22.4, redundancy has been provided that will prevent the loss of power should one of the devices in the line fail. Because the two transformers are located in separate physical enclosures, maintenance can be performed on one leg without dropping power to the facility.

Of equal importance is the method of distributing power *within* a facility to achieve maximum reliability. This task is more difficult when dealing with a campus-type facility or a process or manufacturing plant, where — instead of being concentrated in a single room or floor — the critical loads may be in a number of distant locations. Figure 22.5 illustrates power distribution through the facility using a simple radial system. An incoming line supplies the main and line feeders via a service entrance transformer. This system is suitable for a single building or a small process plant. It is simple, reliable, and lowest in cost. However, such a system must be shut down for routine maintenance, and it is vulnerable to single-point failure. Figure 22.6 illustrates a distributed and redundant power-distribution system that permits transferring loads as required to patch around a fault condition. This configuration also allows portions of the system to be de-energized for maintenance or upgrades without dropping the entire facility. Note the loop arrangement and associated switches that permit optimum flexibility during normal and fault operating conditions.



**Figure 22.3** Simplified service entrance system. (From [2]. Used with permission.)



**Figure 22.4** Fault-tolerant service entrance system. (From [2]. Used with permission.)

### 22.3 Plant Maintenance

Maintenance of the facility electrical system is a key part of any serious energy-management effort. Perform the following steps on a regular basis:

- Measure the current drawn on distribution cables. Document the measurements so that a history of power demand can be compiled.
- Check terminal and splice connections to make sure they are tight.
- Check power-system cables for excessive heating.
- Check cables for insulation problems.
- Clean switchboard and circuit-breaker panels.
- Measure the phase-to-phase load balance at the utility service entrance. Load imbalance can result in inefficient use of ac power.
- Measure and chart the power factor of the load. Develop and post a simplified one-line schematic of the entire power network as well as other building systems, including heating, air-conditioning, security, and alarm functions. A *mimic board* is helpful in this process. Construct the mimic board control panel so that it depicts the entire ac power-distribution system. The board should have active indicators that show what loads or circuit breakers are turned on or off, what functions have been disabled, and key operating parameters, including input voltage, load current, and total kVA demand. Safety considerations require that machinery not be activated from the mimic board. Permit machinery to be energized only at the apparatus. As an alternative, remote control of machines can be provided, if a *remote/local* control switch is provided at the apparatus.

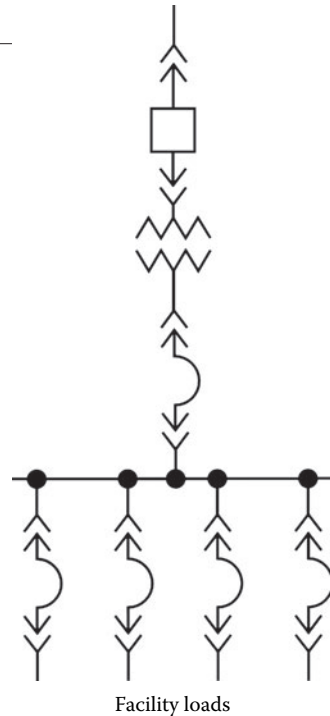


Figure 22.5 Secondary plant distribution using a simple radial configuration. (From [2]. Used with permission.)

Environmental control systems should be monitored closely. Air-conditioning, heating, and ventilation systems often represent a significant portion of the power load of a facility. Computer-based data-logging equipment with process control capability can be of considerable help in monitoring the condition of the equipment. The logger can be programmed to record all pertinent values periodically and to report abnormal conditions.

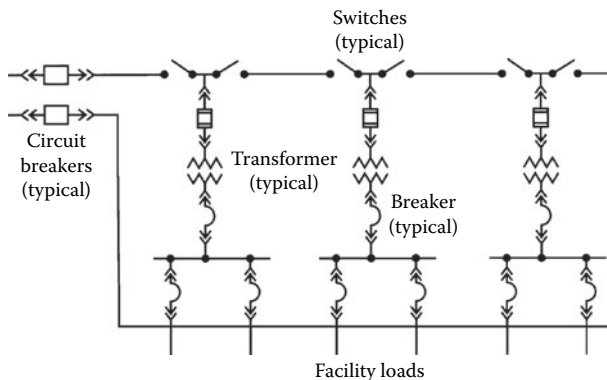


Figure 22.6 A redundant, fault-tolerant secondary plant distribution system. (From [2]. Used with permission.)



### 22.3.1 Switchgear Maintenance

All too often, ac power switchgear is installed at a facility and forgotten — until a problem occurs. A careless approach to regular inspection and cleaning of switchgear has resulted in numerous failures, including destructive fires. The most serious fault in any switchgear assembly is arcing involving the main power bus. Protective devices may fail to open, or open only after a considerable delay. The arcing damage to busbars and enclosures can be significant. Fire often ensues, compounding the damage.

Moisture, combined with dust and dirt, is the greatest deteriorating factor insofar as insulation is concerned. Dust or moisture are thought to account for as much as half of switchgear failures. Initial leakage paths across the surface of bus supports result in flashover and sustained arcing. Contact overheating is another common cause of switchgear failure. Improper circuit-breaker installation or loose connections can result in localized overheating and arcing.

An arcing fault is destructive because of the high temperatures present (more than 6000°F). An arc is not a stationary event. Because of the ionization of gases and the presence of vaporized metal, an arc can travel along bare busbars, spreading the damage and sometimes bypassing open circuit breakers. It has been observed that most faults in three-phase systems involve all phases. The initial fault that triggers the event may involve only one phase, but because of the traveling nature of an arc, damage quickly spreads to the other lines.

Preventing switchgear failure is a complicated discipline, but consider the following general guidelines:

- Install insulated busbars for both medium-voltage and low-voltage switchgear. Each phase of the bus and all connections should be enclosed completely by insulation with electrical, mechanical, thermal, and flame-retardant characteristics suitable for the application.
- Establish a comprehensive preventive maintenance program for the facility. Keep all switchboard hardware clean from dust and dirt. Periodically check connection points for physical integrity.
- Maintain control over environmental conditions. Switchgear exposed to contaminants, corrosive gases, moist air, or high ambient temperatures may be subject to catastrophic failure. Conditions favorable to moisture condensation are particularly perilous, especially when dust and dirt are present.
- Accurately select overcurrent trip settings, and check them on a regular basis. Adjust the trip points of protection devices to be as low as possible, consistent with reliable operation.
- Divide switchgear into compartments that isolate different circuit elements. Consider adding vertical barriers to bus compartments to prevent the spread of arcing and fire.
- Install ground-fault protection devices at appropriate points in the power-distribution system.
- Adhere to all applicable building codes.

### 22.3.2 Ground-System Maintenance

Out of sight, out of mind does not — or, at least, *should* not — apply to a facility ground system. Grounding is a crucial element in achieving reliable operation of electronic equipment. If a ground system has been buried for 10 years or more, it is due for an inspection. Soil conditions vary widely, but few areas have soil that permits a radial- or screen-based ground system to last much more than 15 years.

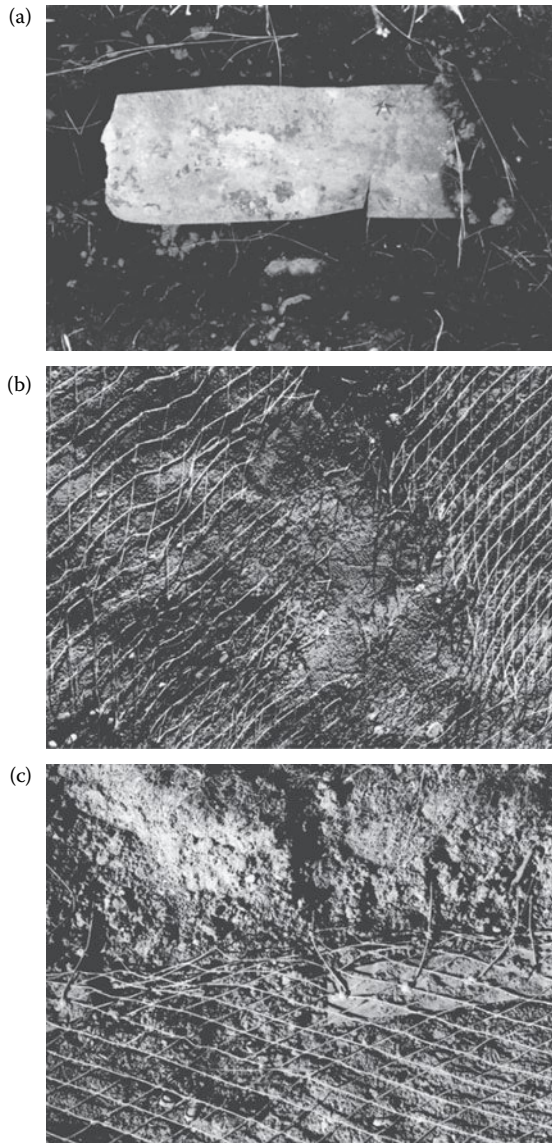
The method of construction and bonding of the ground network also can play a significant role in the ultimate life expectancy of the system. For example, ground conductors secured only by mechanical means (screws and bolts, crimping, and rivets) can quickly break down when exposed to even mild soil conditions. Unless silver-soldered or bonded using an exothermic method, such connections soon will be useless for all practical purposes.

The inspection process involves uncovering portions of the ground system to check for evidence of failure. Pay particular attention to interconnection points, where the greatest potential for problems exists. In some cases, a good metal detector will help identify portions of the ground system. It will not, however, identify breaks in the system. Portions of the ground system still will need to be uncovered to



complete the inspection. Accurate documentation of the placement of ground-system components will aid the inspection effort greatly.

Check any buried mechanical connections carefully. Bolts that have been buried for many years may be severely deteriorated. Carefully remove several bolts, and inspect their condition. If a bolt is severely oxidized, it may twist off as it is removed. After uncovering representative portions of the ground system, document the condition of the ground through notes and photographs. These will serve as a reference point for future observation. The photos in Figure 22.7 illustrate some of the problems that can occur with an aging ground system. Note that many of the problems experienced with the system shown in the photographs resulted from improper installation of components in the first place.



**Figure 22.7** Ground system inspection: (a) Even though a buried copper strap may appear undamaged, give it a pull to be sure. This strap came apart with little effort. (b) Acidic soil conditions created holes in this ground screen. (c) Small pieces of copper strap were used in this ground system to attach radials to the ground screen around the base of a tower. Proper installation procedures would have incorporated a solid piece of strap around the perimeter of the screen for such connections.

## 22.4 References

---

1. Gruz, T. M., "High Availability, Fault-Tolerant AC Power Distribution Systems for Critical Loads, *Proceedings, Power Quality Solutions/Alternative Energy*, Intertec International, Ventura, CA, pp. 20–22, September 1996.
2. DeDad, J. A., "Considerations in Designing a Reliable Power Distribution System," in *Practical Guide to Power Distribution for Information Technology Equipment*, PRIMEDIA Intertec, Overland Park, KS, pp. 4–8, 1997.

## 22.5 Bibliography

---

- Angevine, E., "Controlling Generator and UPS Noise," *Broadcast Engineering*, PRIMEDIA Intertec, Overland Park, KS, March 1989.
- Baietto, R., "How to Calculate the Proper Size of UPS Devices," *Microservice Management*, PRIMEDIA Intertec, Overland Park, KS, March 1989.
- Federal Information Processing Standards Publication No. 94, *Guideline on Electrical Power for ADP Installations*, U.S. Department of Commerce, National Bureau of Standards, Washington, DC, 1983.
- Highnote, R. L., *The IFM Handbook of Practical Energy Management*, Institute for Management, Old Saybrook, CT, 1979.
- Smith, M., "Planning for Standby AC Power," *Broadcast Engineering*, PRIMEDIA Intertec, Overland Park, KS, March 1989.
- Stuart, B., "Maintaining an Antenna Ground System," *Broadcast Engineering*, PRIMEDIA Intertec, Overland Park, KS, October 1986.

# 23

## The Efficient Use of Energy

---

### 23.1 Introduction

---

Utility company power bills are usually a large part of the operating expenses of a facility. To reduce the amount of money spent each month on electricity, engineers must understand the billing methods used by the utility. Saving energy is more complicated than simply turning off unnecessary lights. The amount of money that can be saved through a well-planned energy conservation effort is often substantial. Reductions of 20% are not uncommon, depending upon the facility layout and the extent of energy conservation efforts already under way. Regardless of any monetary savings that might be realized from a power-use-reduction program, the items discussed here should be considered for any well-run facility.

The rate structures of utility companies vary widely from one area of the country to another. Some generalizations can be made, however, with respect to the basic rate-determining factors. The four primary parameters used to determine a customer's bill are

- Energy usage
- Peak demand
- Load factor
- Power factor

These items often can be controlled, to some extent, by the customer.

### 23.2 Energy Usage

---

The kilowatt-hour (kWh) usage of a facility can be reduced by turning off loads such as heating and air-conditioning systems, lights, and office equipment when they are not needed. The installation of timers, photocells, or sophisticated computer-controlled energy-management systems can make substantial reductions in facility kWh demand each month. Common sense will dictate the conservation measures applicable to a particular situation. Obvious items include reducing the length of time high-power equipment is in operation, setting heating and cooling thermostats to reasonable levels, keeping office equipment turned off during the night, and avoiding excessive amounts of indoor or outdoor lighting.

Although energy conservation measures should be taken in every area of facility operation, the greatest savings generally can be found where the largest energy users are located. Transmitter plants, large machinery, and process drying equipment consume a huge amount of power, so particular attention should be given to such hardware. Consider the following:

- Use the waste heat from equipment at the site for other purposes, if practical. In the case of high-power RF generators or transmitters, room heating can be accomplished with a logic-controlled power amplifier exhaust-air recycling system.
- Have a knowledgeable consultant plan the air-conditioning and heating system at the facility for efficient operation.
- Check thermostat settings on a regular basis, and consider installing time-controlled thermostats.
- Inspect outdoor-lighting photocells regularly for proper operation.

- Examine carefully the efficiency of high-power equipment used at the facility. New designs may offer substantial savings in energy costs.

The efficiency of large power loads, such as mainframe computers, transmitters, or industrial RF heaters, is an item of critical importance to energy conservation efforts. Most systems available today are significantly more efficient than their counterparts of just 10 years ago. Plant management often can find economic justification for updating or replacing an older system on the power savings alone. In virtually any facility, energy conservation can best be accomplished through careful selection of equipment, thoughtful system design, and conscientious maintenance practices.

### 23.3 Peak Demand

Conserving energy is a big part of the power bill reduction equation, but it is not the whole story. The *peak demand* of the customer load is an important criterion in the utility company's calculation of rate structures. The peak demand figure is a measure of the maximum load placed on the utility company system by a customer during a predetermined billing cycle. The measured quantities may be kilowatts, kilovolt-amperes, or both. Time intervals used for this measurement range from 15 to 60 min. Billing cycles may be annual or semiannual. Figure 23.1 shows an example of varying peak demand.

If a facility operated at basically the same power consumption level from one hour to the next and one day to the next, the utility company could predict accurately the demand of the load, and then size its equipment (including the allocation of energy reserves) for only the amount of power actually needed. For the example shown in the figure, however, the utility company must size its equipment (including allocated energy reserves) for the peak demand. The area between the peak demand and the actual usage is the margin of inefficiency that the customer forces upon the utility. The peak demand factor is a method used by utility companies to assess penalties for such operation, thereby encouraging the customer to approach a more efficient state of operation (from the utility's viewpoint).

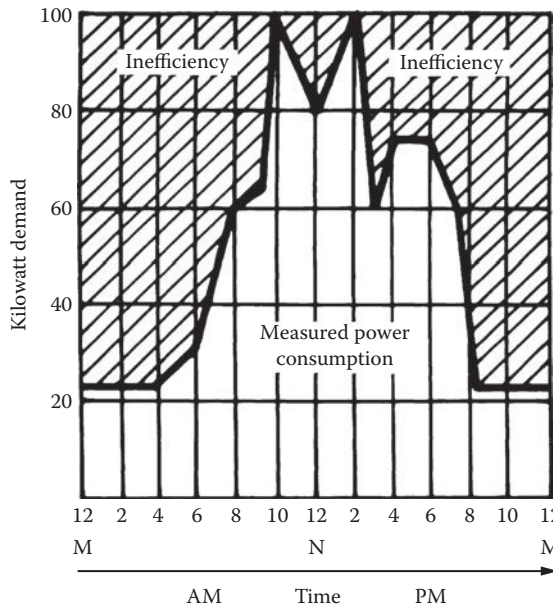


Figure 23.1 The charted power consumption of a facility not practicing energy-management techniques. note the inefficiency that the utility company must absorb when faced with a load such as this.

*Load shedding* is a term used to describe the practice of trimming peak power demand to reduce high-demand penalties. The goal of load shedding is to schedule the operation of nonessential equipment so as to provide a uniform power load to the utility company and, thereby, a better kWh rate. Nearly any operation has certain electric loads that can be rescheduled on a permanent basis or deferred as power demand increases during the day. Figure 23.2 illustrates the results of a load-shedding program. This more efficient operation has a lower overall peak demand and a higher average demand.

Peak demand reduction efforts can cover a wide range of possibilities. It would be unwise from an energy standpoint, for example, to test high-power standby equipment on a summer afternoon, when air-conditioning units may be in full operation. Morning or evening hours would be a better choice, when the air-conditioning is off and the demand of office equipment is reduced. Each operation is unique and requires an individual assessment of load-shedding options.

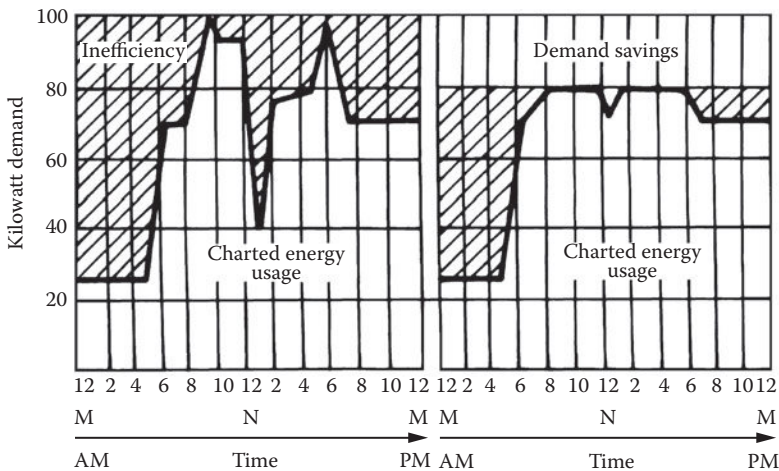
An automated power-demand controller provides an effective method of managing peak demand. A controller can analyze the options available and switch loads as needed to maintain a relatively constant power demand from the utility company. Such systems are programmed to recognize which loads have priority and which loads are nonessential. Power demand then is automatically adjusted by the system, based upon the rate schedule of the utility company. Many computerized demand control systems also provide the customer a printout of the demand profile of the plant, further helping managers analyze and reduce power costs. Figure 23.3 shows one such printout. Note that both energy demand and the costs for that energy are provided.

### 23.4 Load Factor

The load factor on an electric utility company bill is a product of the peak demand and energy usage. It usually is calculated and applied to the customer's bill each month. Reducing either the peak demand or energy usage levels, or both, will decrease this added cost factor. Reducing power factor penalties also will help to reduce load factor charges.

### 23.5 Power Factor

Power factor charges are the result of heavy inductive loading of the utility company system. A poor PF will result in excessive losses along utility company feeder lines because more current is required to

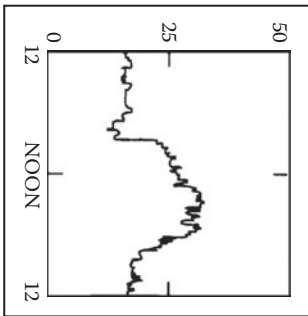


**Figure 23.2** An example of the successful application of a load-shedding program. Energy usage has been spread more evenly throughout the day, resulting in reduced demand and, consequently, a better rate from the utility company.

Service entrance Oct 02 (Mon)  
 Billing demand 12:00:11 AM  
 From: Midnight Sep 30 (Sat)  
 To: Midnight Oct 01 (Sun)  
 Demand interval: 15 min  
 Sliding interval: No  
 Synchronization: None  
 Total:  
 Max: 32.0 kW, 2:40 PM  
 Min: 13.6 kW, 7:40 AM  
 Phase: A-N:  
 Max: 12.9 kW, 5:10 PM  
 Min: 4.1 kW, 7:40 AM  
 Phase: B-N:  
 Max: 10.2 kW, 3:10 PM  
 Min: 4.0 kW, 2:55 AM  
 Phase: C-N:  
 Max: 9.6 kW, 2:55 PM  
 Min: 5.4 kW, 7:40 AM

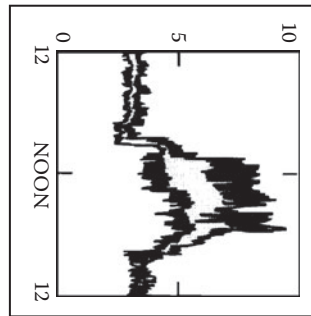
Service entrance Oct 02 (Mon)  
 Cash flow 12:00:20 AM  
 From: Midnight Sep 30 (Sat)  
 To: Midnight Oct 01 (Sun)  
 Total:  
 Max: \$ 9.42/Hr, 5:06 PM  
 Min: \$ 2.32/Hr, 8:20 AM

3030 Site Oct 02 (Mon)  
 Power factor report  
 From: Midnight Sep 24 (Sun)  
 To: Midnight Oct 01 (Sun)  
 3030 Site Oct 02 (Mon)  
 Volt-amps reactive 12:02:54 AM  
 From: Midnight Sep 24 (Sun)  
 To: Midnight Oct 01 (Sun)  
 Total:  
 Max: 62.5 kVAR  
 1:02 PM Sep 25 (Mon)  
 Min: -11.1 kVAR  
 3:17 AM Sep 27 (Wed)  
 Phase: A-N:  
 Max: 39.7 kVAR  
 1:02 PM Sep 25 (Mon)  
 Min: -11.6 kVAR  
 4:00 AM Sep 26 (Tue)  
 Phase: B-N:  
 Max: 18.7 kVAR  
 12:51 PM Sep 27 (Wed)  
 Min: -1.1 kVAR  
 4:10 AM Sep 26 (Tue)  
 Phase: C-N:  
 Max: 29.1 kVAR  
 5:42 PM Sep 27 (Wed)  
 Min: -12.9 kVAR  
 3:17 AM Sep 27 (Wed)



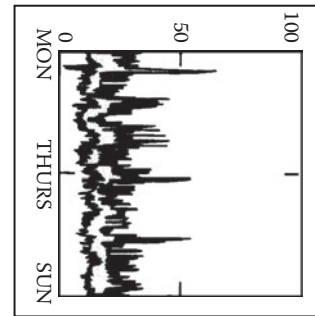
Billing demand (accumulated)  
 Max: 71411.8 W  
 2:39 PM Sep 29 (Fri)  
 Min: 4060.8 W  
 10:16 AM Sep 20 (Wed)

(a)



Cash flow (accumulated)  
 Max: \$ 16.38/Hr  
 2:34 PM Sep 29 (Fri)  
 Min: \$ -0.00/Hr  
 10:18 AM Sep 20 (Wed)

(b)



Instantaneous volt-amps (accumulated)  
 Max: 62456.0 VAR  
 1:02 PM Sep 25 (Mon)  
 Min: -11055.4 VAR  
 3:17 AM Sep 27 (Wed)

(c)

**Figure 23.3** Printout of a facility power profile: (a) billing demand in kW, (b) cost in dollars per hour, (c) demand in kVAR. (After [6].)

supply a particular load with a low PF than would be demanded if the load had a PF close to unity. (The technical aspects of power factor are discussed in Section 3.2.) The power factor charge is a penalty that customers pay for the extra current needed to magnetize motors and other inductive loads. This magnetizing current does not show up on the service drop wattmeter. It is, instead, measured separately or prorated as an additional charge to the customer. The power factor penalty sometimes can be reduced through the addition of on-site PF correction capacitors.

Power factor meters are available for measurement of a given load. It is usually less expensive in the long run, however, to hire a local electrical contractor to conduct a PF survey and recommend correction methods. Possible sources of PF problems include transmitters, blowers, air conditioners, heating equipment, and fluorescent and high-intensity discharge lighting-fixture ballasts.

## 23.6 Reference

---

1. Lawrie, R. H., *Practical Guide to Electrical Energy Efficiency and Reduced Costs*, PRIMEDIA Intertec, Overland Park, KS, 1994.

## 23.7 Bibliography

---

Federal Information Processing Standards Publication No. 94, *Guideline on Electrical Power for ADP Installations*, U.S. Department of Commerce, National Bureau of Standards, Washington, DC , 1983.

Highnote, R. L., *The IFM Handbook of Practical Energy Management*, Institute for Management, Old Saybrook, CT, 1979.



# Safety and Protection Systems

---

## 24.1 Introduction

---

Safety is critically important to engineering personnel who work around powered hardware, especially if they work under considerable time pressures. Safety is not something to be taken lightly. *Life safety* systems are those designed to protect life and property. Such systems include emergency lighting, fire alarms, smoke exhaust and ventilating fans, and site security.

### 24.1.1 Facility Safety Equipment

Personnel safety is the responsibility of the facility manager. Proper life safety procedures and equipment must be installed. Safety-related hardware includes the following:

- *Emergency power off* (EPO) button. EPO pushbuttons are required by safety code for various types of facilities, including data processing (DP) centers. One must be located at each principal exit from the room. Other EPO buttons may be located near operator workstations. The EPO system, intended only for emergencies, disconnects all power to the room, except for lighting.
- Smoke detector. Two basic types of smoke detectors commonly are available. The first compares the transmission of light through air in the room with light through a sealed optical path into which smoke cannot penetrate. Smoke causes a differential or *backscattering* effect that, when detected, triggers an alarm after a preset threshold has been exceeded. The second type of smoke detector senses the ionization of combustion products rather than visible smoke. A mildly radioactive source, usually nickel, ionizes the air passing through a screened chamber. A charged probe captures ions and detects the small current that is proportional to the rate of capture. When combustion products or material other than air molecules enter the probe area, the rate of ion production changes abruptly, generating a signal that triggers the alarm.
- Flame detector. The flame sensor responds not to heated surfaces or objects, but to infrared when it flickers with the unique characteristics of a fire. Such detectors, for example, will respond to a lighted match, but not to a cigarette. The ultraviolet light from a flame also is used to distinguish between hot, glowing objects and open flame.
- Halon. The Halon fire-extinguishing agent is a low-toxicity, compressed gas that is contained in pressurized vessels. Discharge nozzles in data processing rooms and other types of equipment rooms are arranged to dispense the entire contents of a central container or of multiple smaller containers of Halon when actuated by a command from the fire control system. The discharge is sufficient to extinguish flame and stop combustion of most flammable substances. Halon is one of the more common fire-extinguishing agents used for DP applications. Halon systems usually are not practical, however, in large, open-space facilities.
- Water sprinkler. Although water is an effective agent against a fire, activation of a sprinkler system will often cause damage to the equipment it is meant to protect. Interlock systems must drop all power (except for emergency lighting) before the water system is discharged. Most water systems use a two-stage alarm. Two or more fire sensors, often of different design, must signal an alarm condition



before water is discharged into the protected area. Where sprinklers are used, floor drains and EPO controls must be provided.

- Fire damper. Dampers are used to block ventilating passages in strategic parts of the system when a fire is detected. This prevents fire from spreading through the passages and keeps fresh air from fanning the flames. A fire damper system, combined with the shutdown of cooling and ventilating air, enables Halon to be retained in the protected space until the fire is extinguished.

Many life safety system functions can be automated. The decision of what to automate and what to operate manually requires considerable thought. If the life safety control panels are accessible to a large number of site employees, most functions should be automatic. Alarm-silencing controls should be maintained under lock and key. A mimic board can be used to readily identify problem areas. Figure 24.1 illustrates a well-organized life safety control system. Note that fire, HVAC (heating, ventilation, and air-conditioning), security, and EPO controls all are readily accessible. Note also that operating instructions are posted for life safety equipment, and an evacuation route is shown. Important telephone numbers are posted, and a direct-line telephone (not via the building switchboard) is provided. All equipment is located adjacent to a lighted emergency exit door.

Life safety equipment must be maintained just as diligently as the systems that it protects. Conduct regular tests and drills. It is, obviously, not necessary or advisable to discharge Halon or water during a drill.

Configure the life safety control system to monitor not only the premises for dangerous conditions, but also the equipment designed to protect the facility. Important monitoring points include HVAC

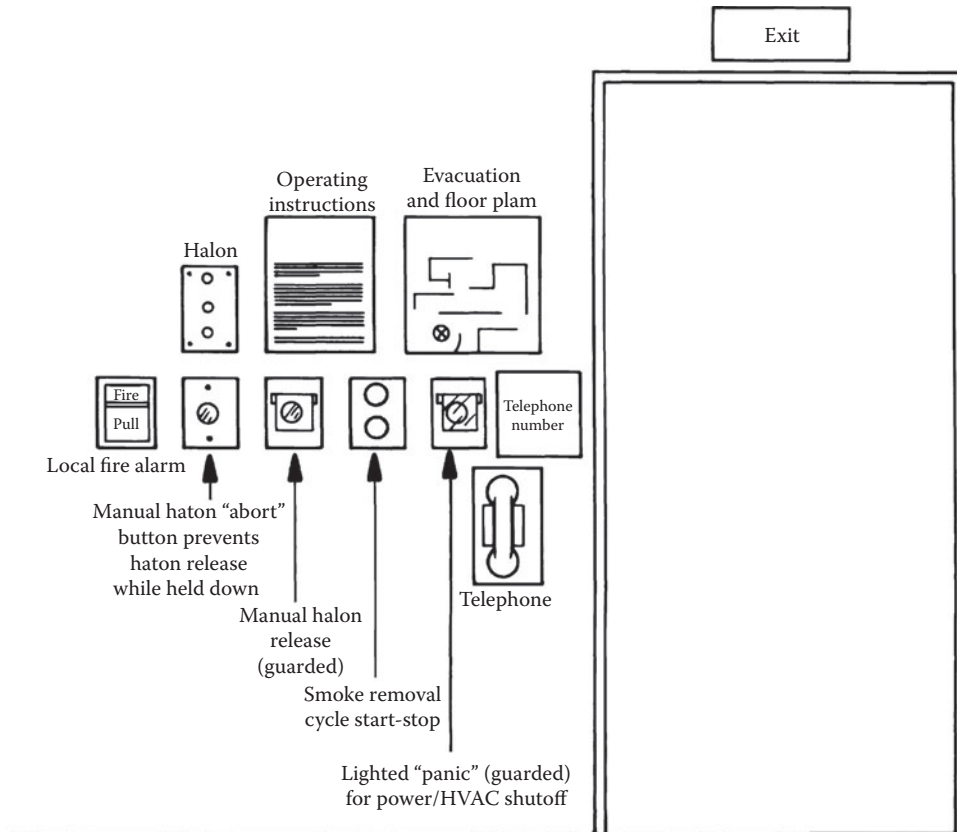


Figure 24.1 A well-organized life safety control station. (After [1].)

machine parameters, water or Halon pressure, emergency battery-supply status, and other elements of the system that could compromise the ability of life safety equipment to carry out its functions. Basic guidelines for life safety systems include the following:

- Carefully analyze the primary threats to life and property within the facility. Develop contingency plans to meet each threat.
- Prepare a life safety manual, and distribute it to all employees at the facility. Require them to read it.
- Conduct drills for employees at random times without notice. Require acceptable performance from employees.
- Prepare simple, step-by-step instructions on what to do in an emergency. Post the instructions in a conspicuous place.
- Assign after-hours responsibility for emergency situations. Prepare a list of supervisors that operators should contact if problems arise. Post the list with phone numbers. Keep the list accurate and up-to-date. Always provide the names of three individuals who can be contacted in an emergency.
- Work with a life safety consultant to develop a coordinated control and monitoring system for the facility. Such hardware will be expensive, but it must be provided. The facility may be able to secure a reduction in insurance rates if comprehensive safety efforts can be demonstrated.
- Interface the life safety system with automatic data-logging equipment so that documentation can be assembled on any event.
- Insist upon complete, up-to-date schematic diagrams for all hardware at the facility. Insist that the diagrams include any changes made during installation or subsequent modification.
- Provide sufficient emergency lighting.
- Provide easy-access emergency exits.

The importance of providing standby power for sensitive loads at commercial and industrial facilities has been outlined previously. It is equally important to provide standby power for life safety systems. A lack of ac power must not render the life safety system inoperative. Sensors and alarm control units should include their own backup battery supplies. In a properly designed system, all life safety equipment will be fully operational despite the loss of all ac power to the facility, including backup power for sensitive loads.

Place cables linking the life safety control system with remote sensors and actuators in separate conduit containing only life safety conductors. Study the National Electrical Code and all applicable local and federal codes relating to safety. Follow them to the letter.

## 24.2 Electric Shock

---

It takes surprisingly little current to injure a person. Studies at Underwriters Laboratories (UL) show that the electrical resistance of the human body varies with the amount of moisture on the skin, the muscular structure of the body, and the applied voltage. The typical hand-to-hand resistance ranges from 500  $\Omega$  to 600 k $\Omega$ , depending on the conditions. Higher voltages have the capability to break down the outer layers of the skin, which can reduce the overall resistance value. UL uses the lower value, 500  $\Omega$ , as the standard resistance between major extremities, such as from the hand to the foot. This value generally is considered the minimum that would be encountered. In fact, it may not be unusual because wet conditions or a cut or other break in the skin significantly reduces human body resistance.

### 24.2.1 Effects on the Human Body

Table 24.1 lists some effects that typically result when a person is connected across a current source with a hand-to-hand resistance of 2.4 k $\Omega$ . The table shows that a current of 50 mA will flow between the hands, if one hand is in contact with a 120 V ac source and the other hand is grounded. The table also indicates that even the relatively small current of 50 mA can produce *ventricular fibrillation* of the heart, and

Table 24.1 The Effects of Current on the Human Body

1 mA or less	No sensation, not felt
More than 3 mA	Painful shock
More than 10 mA	Local muscle contractions, sufficient to cause “freezing” to the circuit for 2.5% of the population
More than 15 mA	Local muscle contractions, sufficient to cause “freezing” to the circuit for 50% of the population
More than 30 mA	Breathing is difficult, can cause unconsciousness
50 to 100 mA	Possible ventricular fibrillation of the heart
100 to 200 mA	Certain ventricular fibrillation of the heart
More than 200 mA	Severe burns and muscular contractions; heart more apt to stop than to go into fibrillation
More than a few amperes	Irreparable damage to body tissues

maybe even cause death. Medical literature describes ventricular fibrillation as very rapid, uncoordinated contractions of the ventricles of the heart, resulting in loss of synchronization between heartbeat and pulse beat. The electrocardiograms shown in Figure 24.2 compare a healthy heart rhythm with one in ventricular fibrillation. Unfortunately, once ventricular fibrillation occurs, it will continue. Barring resuscitation techniques, death will ensue within a few minutes.

The route taken by the current through the body greatly affects the degree of injury. Even a small current, passing from one extremity through the heart to another extremity, is dangerous and capable of causing severe injury or electrocution. There are cases in which a person has contacted extremely high current levels and lived to tell about it. However, when this happens, it is usually because the current passes only through a single limb and not through the entire body. In these instances, the limb is often lost but the person survives.

Current is not the only factor in electrocution. Figure 24.3 summarizes the relationship between current and time on the human body. The graph shows that 100 mA flowing through an adult human body for 2 s will cause death by electrocution. An important factor in electrocution, the *let-go range*, also is shown on the graph. This point marks the amount of current that causes *freezing*, or the inability to let go of a conductor. At 10 mA, 2.5% of the population would be unable to let go of a live conductor; at 15 mA, 50% of the population would be unable to let go of an energized conductor. It is apparent from the graph that even a small amount of current can freeze someone to a conductor. The objective for those

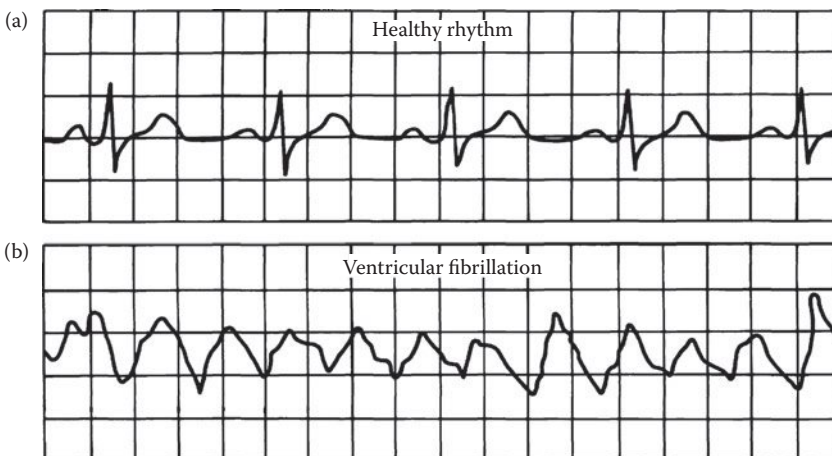


Figure 24.2 Electrocardiogram traces: (a) healthy heart rhythm, (b) ventricular fibrillation of the heart.

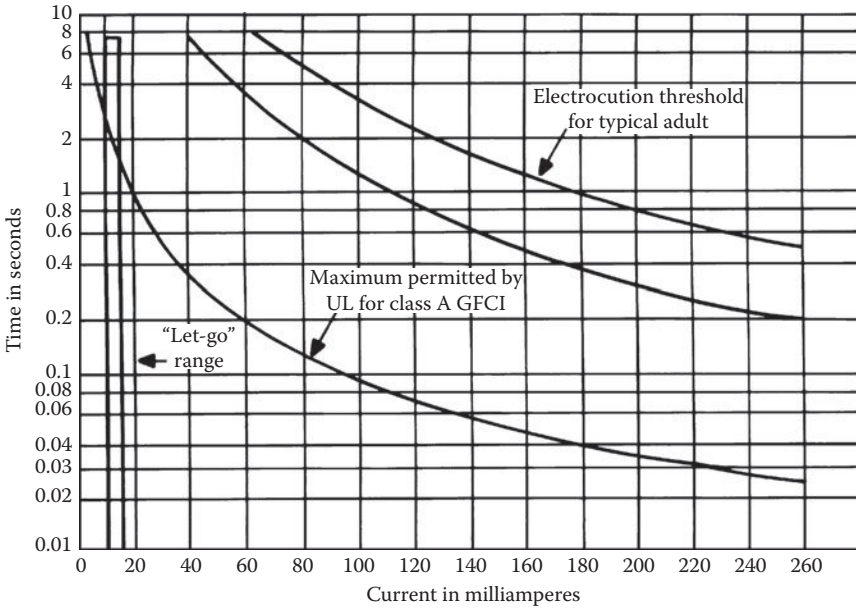


Figure 24.3 Effects of electric current and time on the human body. Note the “let-go” range.

who must work around electric equipment is to protect themselves from electric shock. Table 24.2 lists required precautions for maintenance personnel working near high voltages.

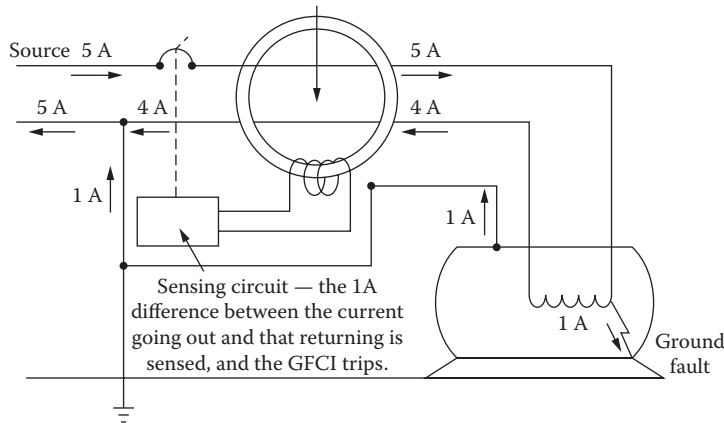
### 24.2.2 Circuit-Protection Hardware

A common primary panel or equipment circuit breaker or fuse will not protect an individual from electrocution. However, the *ground-fault current interrupter* (GFCI), used properly, can help prevent electrocution. Shown in Figure 24.4, the GFCI works by monitoring the current being applied to the load. It

Table 24.2 Required Safety Practices for Engineers Working around High-Voltage Equipment

- ✓ Remove all ac power from the equipment. Do not rely on internal contactors or SCRs to remove dangerous ac.
- ✓ Trip the appropriate power-distribution circuit breakers at the main breaker panel.
- ✓ Place signs as needed to indicate that the circuit is being serviced.
- ✓ Switch the equipment being serviced to the *local control* mode as provided.
- ✓ Discharge all capacitors using the discharge stick provided by the manufacturer.
- ✓ Do not remove, short-circuit, or tamper with interlock switches on access covers, doors, enclosures, gates, panels, or shields.
- ✓ Keep away from live circuits.
- ✓ Allow any component to cool completely before attempting to replace it.
- ✓ If a leak or bulge is found on the case of an oil-filled or electrolytic capacitor, do not attempt to service the part until it has cooled completely.
- ✓ Know which parts in the system contain PCBs. Handle them appropriately.
- ✓ Minimize exposure to RF radiation.
- ✓ Avoid contact with hot surfaces within the system.
- ✓ Do not take chances.

Differential transformer continuously monitors circuit to ensure that all current that flows out to motor or appliances returns to the source via the circuit conductors. If any current leaks to a fault, the sensing circuit opens the circuit breaker and stops all current flow.



**Figure 24.4** Basic design of a ground-fault current interrupter (GFCI).

uses a differential transformer that senses an imbalance in load current. If a current (typically 5 mA,  $\pm$  1 mA on a low-current 120 V ac line) begins flowing between the neutral and ground or between the hot and ground leads, the differential transformer detects the leakage and opens the primary circuit (typically within 2.5 ms).

Occupational Safety and Health Administration (OSHA) rules specify that temporary receptacles (those not permanently wired) and receptacles typically used on construction sites be equipped with GFCI protection. Receptacles on two-wire, single-phase portable and vehicle-mounted generators of not more than 5 kW, where the generator circuit conductors are insulated from the generator frame and all other grounded surfaces, need not be equipped with GFCI outlets.

GFCIs will not protect a person from every type of electrocution. If you become connected to both the neutral and the hot wire, the GFCI will treat you as if you are merely a part of the load and will not open the primary circuit.

For large, three-phase loads, detecting ground currents and interrupting the circuit before injury or damage can occur is a more complicated proposition. The classic method of protection involves the use of a zero-sequence current transformer (CT). Such devices are basically an extension of the single-phase GFCI circuit shown in Figure 24.4. Three-phase CTs have been developed to fit over bus ducts, switchboard buses, and circuit-breaker studs. Rectangular core-balanced CTs are able to detect leakage currents as small as several milliamperes when the system carries as much as 4 kA. “Doughnut-type” toroidal zero-sequence CTs also are available in varying diameters.

The zero-sequence current transformer is designed to detect the magnetic field surrounding a group of conductors. As shown in Figure 24.5, in a properly operating three-phase system, the current flowing through the conductors of the system, including the neutral, goes out and returns along those same conductors. The net magnetic flux detected by the CT is zero. No signal is generated in the transformer winding, regardless of current magnitudes — symmetrical or asymmetrical. If one phase conductor is faulted to ground, however, the current balance will be upset. The ground-fault-detection circuit then will trip the breaker and open the line.

For optimum protection in a large facility, GFCI units are placed at natural branch points of the ac power system. It is, obviously, preferable to lose only a small portion of a facility in the event of a ground fault than it is to have the entire plant dropped. Figure 24.6 illustrates such a distributed system. Sensors are placed at major branch points to isolate any ground fault from the remainder of the distribution network. In this way, the individual GFCI units can be set for higher sensitivity and shorter time delays than would be practical with a large, distributed load. The technology of GFCI devices has improved

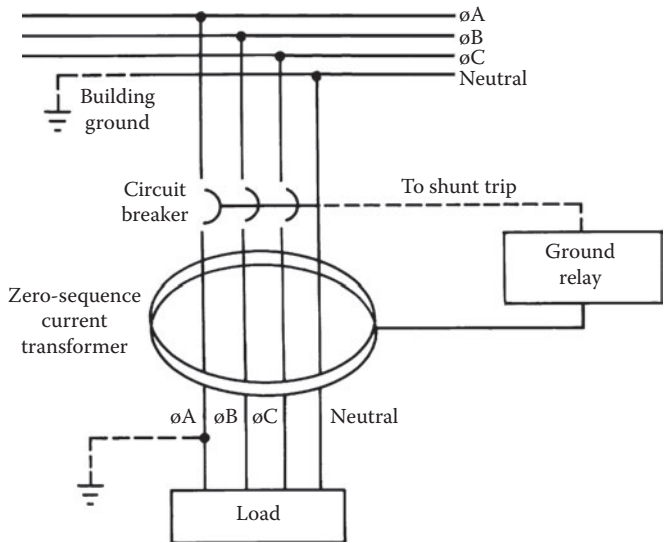


Figure 24.5 Ground-fault detection in a three-phase ac system.

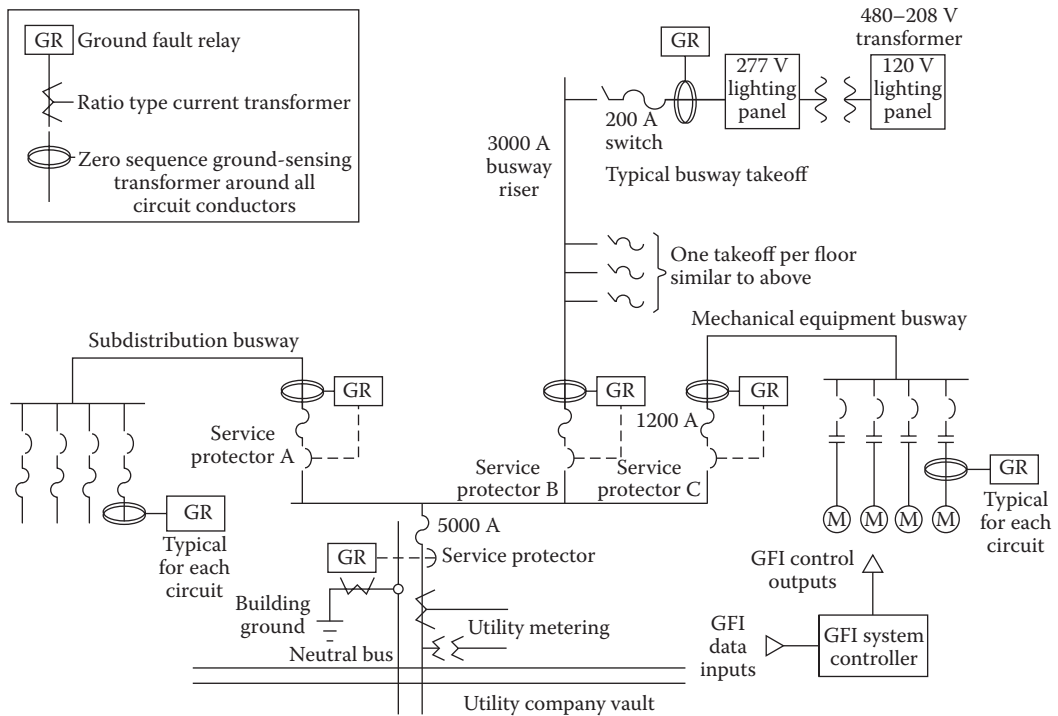


Figure 24.6 Ground-fault protection system for a large, multistory building.

significantly within the past few years. New integrated circuit devices and improved CT designs have provided improved protection components at a lower cost.

Sophisticated GFCI monitoring systems are available that analyze ground-fault currents and isolate the faulty branch circuit. This feature prevents needless tripping of GFCI units up the line toward the utility service entrance. For example, if a ground fault is sensed in a fourth-level branch circuit, the GFCI system controller automatically locks out first-, second-, and third-level devices from operating to clear

the fault. The problem, therefore, is safely confined to the fourth-level branch. The GFCI control system is designed to operate in a fail-safe mode. In the event of a control-system shutdown, the individual GFCI trip relays would operate independently to clear whatever fault currents may exist.

Any facility manager would be well-advised to hire an experienced electrical contractor to conduct a full ground-fault protection study. Direct the contractor to identify possible failure points and to recommend corrective actions.

An extensive discussion of GFCI principals and practices can be found in Reference 2.

### 24.2.3 Working with High Voltage

Rubber gloves are a common safety measure used by engineers working on high-voltage equipment. These gloves are designed to provide protection from hazardous voltages when the wearer is working on “hot” circuits. Although the gloves may provide some protection from these hazards, placing too much reliance on them poses the potential for disastrous consequences. There are several reasons why gloves should be used only with a great deal of caution and respect. A common mistake made by engineers is to assume that the gloves always provide complete protection. The gloves found in some facilities may be old and untested. Some may even have been “repaired” by users, perhaps with electrical tape. Few tools could be more hazardous than such a pair of gloves.

Know the voltage rating of the gloves. Gloves are rated differently for ac and dc voltages. For instance, a *class 0* glove has a minimum dc breakdown voltage of 35 kV; the minimum ac breakdown voltage, however, is only 6 kV. Furthermore, high-voltage rubber gloves are not tested at RF frequencies, and RF can burn a hole in the best of them. Working on live circuits involves much more than simply wearing a pair of gloves. It involves a frame of mind — an awareness of everything in the area, especially ground points.

Gloves alone may not be enough to protect an individual in certain situations. Recall the axiom of keeping one hand in your pocket while working on a device with current flowing? The axiom actually is based on simple electricity. It is not just the hot connection that causes the problem; it is the ground connection that permits current flow. Studies have showed that more than 90% of electric equipment fatalities occurred when the grounded person contacted a live conductor. Line-to-line electrocution accounted for less than 10% of the deaths.

When working around high voltages, always look for grounded surfaces — and keep away from them. Even concrete can act as a ground if the voltage is high enough. If work must be conducted in live cabinets, consider using — in addition to rubber gloves — a rubber floor mat, rubber vest, and rubber sleeves. Although this may seem to be a lot of trouble, consider the consequences of making a mistake. Of course, the best troubleshooting methodology is never to work on any circuit unless you are sure no hazardous voltages are present. In addition, any circuits or contactors that normally contain hazardous voltages should be grounded firmly before work begins.

Another important safety rule is to never work alone. Even if a trained assistant is not available when maintenance is performed, someone should accompany you and be available to help in an emergency.

### 24.2.4 First Aid Procedures

Be familiar with first aid treatment for electric shock and burns. Always keep a first aid kit on hand at the facility. [Figure 24.7](#) illustrates the basic treatment for electric shock victims. Copy the information, and post it in a prominent location. Better yet, obtain more detailed information from your local heart association or Red Cross chapter. Personalized instruction on first aid usually is available locally. [Table 24.3](#) lists basic first aid procedures for burns.

For electric shock, the best first aid is prevention. In the event that an individual has sustained or is sustaining an electric shock at the work place, several guidelines are suggested, as detailed next.

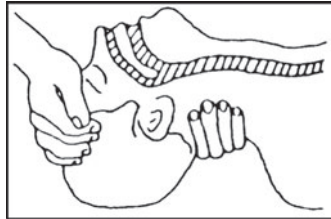


**Treatment of electrical shock**

**1. If victim is not responsive, follow the A-B-Cs of basic life support.**

**A Airway**

If unconscious open airway



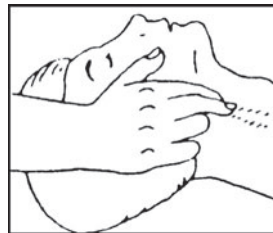
- Lift up neck
- Push forehead back
- Clear out mouth if necessary
- Observe for breathing

**B Breathing**

If not breathing begin artificial breathing



- Tilt head
- Pinch nostrils
- Make airtight seal
- 4 quick full breaths

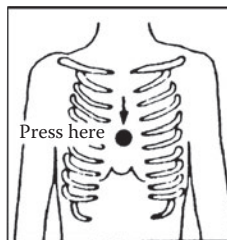


Check carotid pulse.  
If pulse absent.  
Begin artificial circulation.

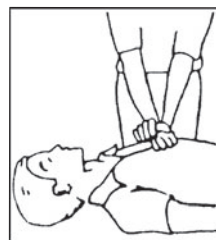
Remember, mouth to mouth resuscitation must be commenced as soon as possible

**C Circulation**

Depress sternum  
1 ½ to 2 inches



One rescuer:  
15 compressions. 2 quick breaths approx. Rate of compressions — 80 per minute



Two rescuers:  
5 compressions. 1 breath approx. Rate of compressions — 60 per minute

Do not interrupt the rhythm of compressions when a second person is giving breath

**2. If victim is responsive, keep him warm and quiet, loosen clothing and place in reclining position.**

Place victim flat on his back on a hard surface call for medical assistance as soon as possible.

Figure 24.7 Basic first aid treatment for electric shock.



Table 24.3 Basic First Aid Procedures

---

For extensively burned and broken skin:

- ✓ Cover affected area with a clean sheet or cloth.
- ✓ Do not break blisters, remove tissue, remove adhered particles of clothing, or apply any salve or ointment.
- ✓ Treat victim for shock as required.
- ✓ Arrange for transportation to a hospital as quickly as possible.
- ✓ If victim's arms or legs are affected, keep them elevated.
- ✓ If medical help will not be available within an hour and the victim is conscious and not vomiting, prepare a weak solution of salt and soda. Mix 1 teaspoon of salt and 1/2-teaspoon of baking soda to each quart of tepid water. Allow the victim to sip slowly about 4 oz (half a glass) over a period of 15 min. Discontinue fluid intake if vomiting occurs. (Do not allow alcohol consumption.)

For less severe burns (first- and second-degree):

- ✓ Apply cool (not ice-cold) compresses using the cleanest available cloth article.
  - ✓ Do not break blisters, remove tissue, remove adhered particles of clothing, or apply salve or ointment.
  - ✓ Apply clean, dry dressing if necessary.
  - ✓ Treat victim for shock as required.
  - ✓ Arrange for transportation to a hospital as quickly as possible.
  - ✓ If victim's arms or legs are affected, keep them elevated.
- 

#### 24.2.4.1 Shock in Progress

For the case when a co-worker is receiving an electric shock and cannot let go of the electrical source, the safest action is to trip the circuit breaker that energizes the circuit involved, or to pull the power-line plug on the equipment involved if the latter can be accomplished safely [2]. Under no circumstances should the rescuer touch the individual who is being shocked, because the rescuer's body may then also be in the dangerous current path. If the circuit breaker or equipment plug cannot be located, then an attempt can be made to separate the victim from the electrical source through the use of a nonconducting object such as a wooden stool or a wooden broom handle. Use only an *insulating* object and nothing that contains metal or other electrically conductive material. The rescuer must be very careful not to touch the victim or the electrical source and thus become a second victim.

If such equipment is available, hot sticks *used in conjunction with lineman's gloves* may be applied to push or pull the victim away from the electrical source. Pulling the hot stick normally provides the greatest control over the victim's motion and is the safest action for the rescuer. After the electrical source has been turned off, or the victim can be reached safely, immediate first aid procedures should be implemented.

#### 24.2.4.2 Shock No Longer in Progress

If the victim is conscious and moving about, have the victim sit down or lie down. Sometimes there is a delayed reaction to an electrical shock that causes the victim to collapse. Call 911 or the appropriate plant-site paramedic team immediately. If there is a delay in the arrival of medical personnel, check for electrical burns. In the case of severe shock, there will normally be burns at a minimum of two sites: the entry point for the current and the exit point(s). Cover the burns with dry (and sterile, preferably) dressings. Check for possible bone fractures if the victim was violently thrown away from the electrical source and possibly impacted objects in the vicinity. Apply splints as required if suitable materials are available and you have appropriate training. Cover the victim with a coat or blanket if the environmental temperature is below room temperature, or the victim complains of feeling cold.

If the victim is unconscious, call 911 or the appropriate plant-site paramedic team immediately. In the interim, check to see if the victim is breathing and if a pulse can be felt at either the inside of a wrist above the thumb joint (radial pulse) or in the neck above and to either side of the Adam's apple (carotid

pulse). It is usually easier to feel the pulse in the neck as opposed to the wrist pulse, which may be weak. The index and middle finger should be used to sense the pulse, and not the thumb. Many individuals have an apparent thumb pulse that can be mistaken for the victim's pulse. If a pulse can be detected but the victim is not breathing, begin mouth-to-mouth respiration if you know how to do so. If no pulse can be detected (presumably the victim will not be breathing), carefully move the victim to a firm surface and begin cardiopulmonary resuscitation if you have been trained in the use of CPR. Respiratory arrest and cardiac arrest are crisis situations. Because of loss of the oxygen supply to the brain, permanent brain damage can occur after several minutes even if the victim is successfully resuscitated.

Ironically, the treatment for cardiac arrest induced by an electric shock is a massive countershock, which causes the entire heart muscle to contract. The random and uncoordinated ventricular fibrillation contractions (if present) are thus stilled. Under ideal conditions, normal heart rhythm is restored once the shock current ceases. The countershock is generated by a cardiac defibrillator, various portable models of which are available for use by emergency medical technicians and other *trained* personnel. Although portable defibrillators may be available at industrial sites where there is a high risk of electrical shock to plant personnel, they should be used only by *trained* personnel. Application of a defibrillator to an unconscious subject whose heart is beating can induce cardiac standstill or ventricular fibrillation, just the conditions that the defibrillator was designed to correct.

## 24.3 Polychlorinated Biphenyls

*Polychlorinated biphenyls* (PCBs) belong to a family of organic compounds known as *chlorinated hydrocarbons*. Virtually all PCBs in existence today have been synthetically manufactured. PCBs are of a heavy, oil-like consistency and have a high boiling point, a high degree of chemical stability, low flammability, and low electrical conductivity. These characteristics led to the past widespread use of PCBs in high-voltage capacitors and transformers. Commercial products containing PCBs were distributed widely from 1957 to 1977 under several trade names, including:

- Aroclor
- Pyroclor
- Sanotherm
- Pyranol
- Askarel

Askarel also is a generic name used for nonflammable dielectric fluids containing PCBs. Table 24.4 lists some common trade names for Askarel. These trade names typically are listed on the nameplate of a PCB transformer or capacitor.

### 24.3.1 Health Risk

PCBs are harmful because, once they are released into the environment, they tend not to break apart into other substances. Instead, PCBs persist, taking several decades to slowly decompose. By remaining in the environment, they can be taken up and stored in the fatty tissues of all organisms, from which they are released slowly into the bloodstream. Therefore, because of the storage in fat, the concentration of PCBs in body tissues can increase with time, even though PCB exposure levels may be quite low. This process is

**Table 24.4** Commonly Used Names for PCB Insulating Material

Apirolio	Abestol	Askarel	Aroclor B	Chlorextol	Chlophen
Chlorinol	Clorphon	Diaclor	DK	Dykanol	EEC-18
Elemex	Eucarel	Fenclor	Hyvol	Inclor	Inerteen
Kanechlor	No-Flamol	Phenodlor	Pydraul	Pyralene	Pyranol
Pyroclor	Sal-T-Kuhl	Santothern FR	Santovac	Solvool	Therminal

called *bioaccumulation*. Furthermore, as PCBs accumulate in the tissues of simple organisms, which are consumed by progressively higher organisms, the concentration increases. This process is referred to as *biomagnification*. These two factors are especially significant because PCBs are harmful even at low levels. Specifically, PCBs have been shown to cause chronic (long-term) toxic effects in some species of animals and aquatic life. Well-documented tests on laboratory animals show that various levels of PCBs can cause reproductive effects, gastric disorders, skin lesions, and cancerous tumors.

PCBs can enter the body through the lungs, the gastrointestinal tract, and the skin. After absorption, PCBs are circulated in the blood throughout the body and stored in fatty tissues and skin, as well as in a variety of organs, including the liver, kidneys, lungs, adrenal glands, brain, and heart.

The health risk lies not only in the PCB itself, but also in the chemicals developed when PCBs are heated. Laboratory studies have confirmed that PCB by-products, including *polychlorinated dibenzofurans* (PCDFs) and *polychlorinated dibenzo-p-dioxins* (PCDDs), are formed when PCBs or chlorobenzenes are heated to temperatures ranging from approximately 900 to 1300°F. Unfortunately, these products are more toxic than PCBs themselves.

### 24.3.2 Governmental Action

The U.S. Congress took action to control PCBs in October 1975, by passing the Toxic Substances Control Act (TSCA). A section of this law specifically directed the EPA to regulate PCBs. Three years later, the EPA issued regulations to implement a congressional ban on the manufacture, processing, distribution, and disposal of PCBs. Since that time, several revisions and updates have been issued by the EPA. One of these revisions, issued in 1982, specifically addressed the type of equipment used in industrial plants. Failure to properly follow the rules regarding the use and disposal of PCBs has resulted in high fines and some jail sentences.

Although PCBs no longer are being produced for electric products in the U. S., significant numbers still exist. The threat of widespread contamination from PCB fire-related incidents is one reason behind the EPA's efforts to reduce the number of PCB products in the environment. The users of high-power equipment are affected by the regulations primarily because of the widespread use of PCB transformers and capacitors. These components usually are located in older (pre-1979) systems, so this is the first place to look for them. However, some facilities also maintain their own primary power transformers. Unless these transformers are of recent vintage, it is possible they too contain a PCB dielectric. [Table 24.5](#) lists the primary classifications of PCB devices.

### 24.3.3 PCB Components

The two most common PCB components are transformers and capacitors. A PCB transformer is one containing at least 500 parts per million (ppm) PCBs in the dielectric fluid. An Askarel transformer generally has 600,000 ppm or more. A PCB transformer can be converted to a *PCB-contaminated device* (50 to 500 ppm) or a *nonPCB device* (less than 50 ppm) by being drained, refilled, and tested. The testing must not take place until the transformer has been in service for a minimum of 90 days. Note that this is *not* something that a maintenance technician can do. It is the exclusive domain of specialized remanufacturing companies.

PCB transformers must be inspected quarterly for leaks. However, if an impervious dike (sufficient to contain all the liquid material) is built around the transformer, the inspections can be conducted yearly. Similarly, if the transformer is tested and found to contain less than 60,000 ppm, a yearly inspection is sufficient. Failed PCB transformers cannot be repaired; they must be disposed of properly.

If a leak develops, it must be contained and daily inspections must begin. A cleanup must be initiated as soon as possible, but no later than 48 hours after the leak is discovered. Adequate records must be kept of all inspections, leaks, and actions taken for 3 years after disposal of the component. Combustible materials must be kept a minimum of 5 m from a PCB transformer and its enclosure.

Table 24.5 Definition of PCB Terms as Identified by the EPA

	Term	Definition
PCB	Any chemical substance that is limited to the biphenyl molecule that has been chlorinated to varying degrees, or any combination of substances that contain such substances.	PCB dielectric fluids, PCB heat-transfer fluids, PCB hydraulic fluids, 2,2',4-trichlorobiphenyl
PCB article	Any manufactured article, other than a PCB container, that contains PCBs and whose surface has been in direct contact with PCBs.	Capacitors, transformers, electric motors, pumps, pipes
PCB container	A device used to contain PCBs or PCB articles, and whose surface has been in direct contact with PCBs.	Packages, cans, bottles, bags, barrels, drums, tanks
PCB article container	A device used to contain PCB articles or equipment, and whose surface has not been in direct contact with PCBs.	Packages, cans, bottles, bags, barrels, drums, tanks
PCB equipment	Any manufactured item, other than a PCB container or PCB article container, which contains a PCB article or other PCB equipment.	Microwave ovens, fluorescent light ballasts, electronic equipment
PCB item	Any PCB article, PCB article container, PCB container, or PCB equipment that deliberately or unintentionally contains, or has as a part of it, any PCBs.	See PCB article, PCB article container, PCB container, and PCB equipment
PCB transformer	Any transformer that contains PCBs in concentrations of 500 ppm or greater.	High-power transformers
PCB contaminated	Any electric equipment that contains more than 50 ppm, but less than 500 ppm, of PCBs. (Oil-filled electric equipment other than circuit breakers, reclosers, and cable whose PCB concentration is unknown must be assumed to be PCB-contaminated electric equipment.)	Transformers, capacitors, circuit breakers, reclosers, voltage regulators, switches, cable, electromagnets

As of October 1, 1990, the use of PCB transformers (500 ppm or greater) was prohibited in or near commercial buildings with secondary voltages of 480 Vac or higher. The use of radial PCB transformers was allowed if certain electrical protection was provided.

The EPA regulations also require that the operator notify others of the possible dangers. All PCB transformers (including those in storage for reuse) must be registered with the local fire department. Supply the following information:

- The location of the PCB transformer(s).
- Address(es) of the building(s). For outdoor PCB transformers, provide the outdoor location.
- Principal constituent of the dielectric fluid in the transformer(s).
- Name and telephone number of the contact person in the event of a fire involving the equipment.

Any PCB transformers used in a commercial building must be registered with the building owner. All owners of buildings within 30 m of such PCB transformers also must be notified. In the event of a fire-related incident involving the release of PCBs, immediately notify the Coast Guard National Spill Response Center at 1-800-424-8802. Also take appropriate measures to contain and control any possible PCB release into water.

Capacitors are divided into two size classes: *large* and *small*. The following are guidelines for classification:

- A PCB small capacitor contains less than 1.36 kg (3 lb) dielectric fluid. A capacitor having less than 100 in<sup>3</sup> also is considered to contain less than 3 lb dielectric fluid.
- A PCB large capacitor has a volume of more than 200 in<sup>3</sup> and is considered to contain more than 3 lb dielectric fluid. Any capacitor having a volume from 100 to 200 in<sup>3</sup> is considered to contain 3 lb dielectric, provided the total weight is less than 9 lb.
- A PCB large low-voltage capacitor contains 3 lb or more dielectric fluid and operates below 2 kV.
- A PCB large high-voltage capacitor contains 3 lb or more dielectric fluid and operates at 2 kV or greater voltages.

The use, servicing, and disposal of PCB small capacitors is not restricted by the EPA unless there is a leak. In that event, the leak must be repaired or the capacitor disposed of. Disposal can be performed by an approved incineration facility, or the component can be placed in a specified container and buried in an approved chemical waste landfill. Currently, chemical waste landfills are only for disposal of liquids containing 50 to 500 ppm PCBs and for solid PCB debris. Items such as capacitors that are leaking oil containing greater than 500 ppm PCBs should be taken to an EPA-approved PCB disposal facility.

### 24.3.4 Identifying PCB Components

The first task for the facility manager is to identify any PCB items on the premises. Equipment built after 1979 probably does not contain any PCB-filled devices. Even so, inspect all capacitors, transformers, and power switches to be sure. A call to the manufacturer also may help. Older equipment (pre-1979) is more likely to contain PCB transformers and capacitors. A liquid-filled transformer usually has cooling fins, and the nameplate may provide useful information about its contents. If the transformer is unlabeled or the fluid is not identified, it must be treated as a PCB transformer. Untested (not analyzed) mineral-oil-filled transformers are assumed to contain at least 50 ppm, but less than 500 ppm, PCBs. This places them in the category of PCB-contaminated electric equipment, which has different requirements than PCB transformers. Older high-voltage systems are likely to include both large and small PCB capacitors. Equipment rectifier panels, exciter/modulators, and power-amplifier cabinets may contain a significant number of small capacitors. In older equipment, these capacitors often are Askarel-filled. Unless leaking, these devices pose no particular hazard. If a leak does develop, follow proper disposal techniques. Also, liquid-cooled rectifiers may contain Askarel. Even though their use is not regulated, treat them as a PCB article, as if they contain at least 50 ppm PCBs. Never make assumptions about PCB contamination; check with the manufacturer to be sure.

Any PCB article or container being stored for disposal must be date-tagged when removed and inspected for leaks every 30 days. It must be removed from storage and disposed of within 1 year from the date it was placed in storage. Items being stored for disposal must be kept in a storage facility meeting the requirements of 40 Code of Federal Regulations (CFR), Part 761.65(b)(1) unless they fall under alternative regulation provisions. There is a difference between PCB items stored for disposal and those stored for reuse. Once an item has been removed from service and tagged for disposal, it cannot be returned to service.

### 24.3.5 Labeling PCB Components

After identifying PCB devices, proper labeling is the second step that must be taken by the facility manager. PCB article containers, PCB transformers, and large high-voltage capacitors must be marked with a standard 6-in. × 6-in. large marking label (ML) as shown in [Figure 24.8](#). Equipment containing these transformers or capacitors also should be marked. PCB large low-voltage (less than 2 kV) capacitors need not be labeled until removed from service. If the capacitor or transformer is too small to hold the large label, a smaller 1-in. × 2-in. label is approved for use. Labeling each PCB small capacitor is not required.



**Figure 24.8** Marking label (ML) used to identify PCB transformers and PCB large capacitors.

However, any equipment containing PCB small capacitors should be labeled on the outside of the cabinet or on access panels. Properly label any spare capacitors and transformers that fall under the regulations. Identify with the large label any doors, cabinet panels, or other means of access to PCB transformers. The label must be placed so that it can be read easily by firefighters. All areas used to store PCBs and PCB items for disposal must be marked with the large (6-in. × 6-in.) PCB label.

### 24.3.6 Record-Keeping

Inspections are a critical component in the management of PCBs. EPA regulations specify a number of steps that must be taken and the information that must be recorded. Table 24.6 summarizes the schedule requirement, and Table 24.7 can be used as a checklist for each transformer inspection. This record must be retained for 3 years. In addition to the inspection records, some facilities may need to maintain an annual report. This report details the number of PCB capacitors, transformers, and other PCB items on the premises. The report must contain the dates when the items were removed from service, their disposition, and detailed information regarding their characteristics. Such a report must be prepared if the facility uses or stores at least one PCB transformer containing greater than 500 ppm PCBs, 50 or more PCB large capacitors, or at least 45 kg of PCBs in PCB containers. Retain the report for 5 years after the facility ceases using or storing PCBs and PCB items in the prescribed quantities. Table 24.8 lists the information required in the annual PCB report.

**Table 24.6** The Inspection Schedule Required for PCB Transformers and Other Contaminated Devices

PCB Transformers	Standard PCB transformer	Quarterly
	If full-capacity impervious dike is added	Annually
	If retrofitted to < 60,000 ppm PCB	Annually
	If leak is discovered, clean up ASAP (retain these records for 3 years)	Daily
PCB article or container stored for disposal (remove and dispose of within 1 year)		Monthly
Retain all records for 3 years after disposing of transformers.		

**Table 24.7** Inspection Checklist for PCB Components

---

Transformer location:  
 Date of visual inspection:  
 Leak discovered? (Yes/No):  
 If yes, date discovered (if different from inspection date):  
 Location of leak:  
 Person performing inspection:  
 Estimate of the amount of dielectric fluid released from leak:  
 Date of cleanup, containment, repair, or replacement:  
 Description of cleanup, containment, or repair performed:

Results of any containment and daily inspection required for uncorrected active leaks:

---

**Table 24.8** Required Information for PCB Annual Report

---

I. PCB device background information:

- a. Dates when PCBs and PCB items are removed from service.
- b. Dates when PCBs and PCB items are placed into storage for disposal and are placed into transport for disposal.
- c. The quantities of the items removed from service, stored, and placed into transport are to be indicated using the following breakdown:
  - (1) Total weight, in kilograms, of any PCB and PCB items in PCB containers, including identification of container contents (such as liquids and capacitors).
  - (2) Total number of PCB transformers and total weight, in kilograms, of any PCBs contained in the transformers.
  - (3) Total number of PCB large high- or low-voltage capacitors.

II. The location of the initial disposal or storage facility for PCBs and PCB items removed from service, and the name of the facility owner or operator.

III. Total quantities of PCBs and PCB items remaining in service at the end of calendar year per the following breakdown:

- a. Total weight, in kilograms, of any PCB and PCB items in PCB containers, including the identification of container contents (such as liquids and capacitors).
- b. Total number of PCB transformers and total weight, in kilograms, of any PCBs contained in the transformers.
- c. Total number of PCB large high- or low-voltage capacitors.

---

### 24.3.7 Disposal

Disposing of PCBs is not a minor consideration. Before contracting with a company for PCB disposal, verify its license with the area EPA office. That office also can supply background information on the company's compliance and enforcement history.

The fines levied for improper disposal are not mandated by federal regulations. Rather, the local EPA administrator, usually in consultation with local authorities, determines the cleanup procedures and costs. Civil penalties for administrative complaints issued for violations of the PCB regulations are determined according to a matrix provided in the PCB penalty policy. This policy, published in the Federal Register, considers the amount of PCBs involved and the potential for harm posed by the violation.

### 24.3.8 Proper Management

Properly managing the PCB risk is not difficult. The keys are to understand the regulations and to follow them carefully. A PCB management program should include the following steps:



- Locate and identify all PCB devices. Check all stored or spare devices.
- Properly label PCB transformers and capacitors according to EPA requirements.
- Perform the required inspections, and maintain an accurate log of PCB items, their location, inspection results, and actions taken. These records must be maintained for 3 years after disposal of the PCB component.
- Complete the annual report of PCBs and PCB items by July 1 of each year. This report must be retained for 5 years.
- Arrange for any necessary disposal through a company licensed to handle PCBs. If there are any doubts about the company's license, contact the EPA.
- Report the location of all PCB transformers to the local fire department and owners of any nearby buildings.

The importance of following the EPA regulations cannot be overstated.

## 24.4 OSHA Safety Requirements

The federal government has taken a number of steps to help improve safety within the workplace. OSHA, for example, helps industries to monitor and correct safety practices. The agency's records show that electrical standards are among the most frequently violated of all safety standards. Table 24.9 lists 16 of the most common electrical violations, which include these areas:

- Protective covers
- Identification and marking
- Extension cords
- Grounding

**Table 24.9** Sixteen Common OSHA Violations (*After* [3].)

Fact Sheet No.	Subject	NEC Reference
1	Guarding of live parts	110-17
2	Identification	110-22
3	Uses allowed for flexible cord	400-7
4	Prohibited uses of flexible cord	400-8
5	Pull at joints and terminals must be prevented	400-10
6-1	Effective grounding, Part 1	250-51
6-2	Effective grounding, Part 2	250-51
7	Grounding of fixed equipment, general	250-42
8	Grounding of fixed equipment, specific	250-43
9	Grounding of equipment connected by cord and plug	250-45
10	Methods of grounding, cord and plug-connected equipment	250-59
11	AC circuits and systems to be grounded	250-5
12	Location of overcurrent devices	240-24
13	Splices in flexible cords	400-9
14	Electrical connections	110-14
15	Marking equipment	110-21
16	Working clearances about electric equipment	110-16



### 24.4.1 Protective Covers

Exposure of live conductors is a common safety violation. All potentially dangerous electric conductors should be covered with protective panels. The danger is that someone can come into contact with the exposed, current-carrying conductors. It also is possible for metallic objects such as ladders, cable, or tools to contact a hazardous voltage, creating a life-threatening condition. Open panels also present a fire hazard.

### 24.4.2 Identification and Marking

Properly identify and label all circuit breakers and switch panels. The labels for breakers and equipment switches may be years old and may no longer describe the equipment that is actually in use. This confusion poses a safety hazard. Improper labeling of the circuit panel can lead to unnecessary damage — or worse, casualties — if the only person who understands the system is unavailable in an emergency. If there are a number of devices connected to a single disconnect switch or breaker, provide a diagram or drawing for clarification. Label with brief phrases, and use clear, permanent, and legible markings.

Equipment marking is a closely related area of concern. This is not the same thing as equipment identification. Marking equipment means labeling the equipment breaker panels and ac disconnect switches according to device rating. Breaker boxes should contain a nameplate showing the manufacturer name, rating, and other pertinent electrical factors. The intent of this rule is to prevent devices from being subjected to excessive loads or voltages.

### 24.4.3 Extension Cords

Extension (flexible) cords often are misused. Although it may be easy to connect a new piece of equipment with a flexible cord, be careful. The National Electrical Code lists only eight approved uses for flexible cords.

The use of a flexible cord where the cable passes through a hole in the wall, ceiling, or floor is an often-violated rule. Running the cord through doorways, windows, or similar openings also is prohibited. A flexible cord should not be attached to building surfaces or concealed behind building walls or ceilings. These common violations are illustrated in [Figure 24.9](#).

Along with improper use of flexible cords, failure to provide adequate strain relief on connectors is a common problem. Whenever possible, use manufactured cable connections.

### 24.4.4 Grounding

OSHA regulations describe two types of grounding: *system grounding* and *equipment grounding*. System grounding actually connects one of the current-carrying conductors (such as the terminals of a supply transformer) to ground. (See [Figure 24.10](#).) Equipment grounding connects all the noncurrent-carrying metal surfaces together and to ground. From a grounding standpoint, the only difference between a grounded electrical system and an ungrounded electrical system is that the *main-bonding jumper* from the service equipment ground to a current-carrying conductor is omitted in the ungrounded system.

The system ground performs two tasks:

- It provides the final connection from equipment-grounding conductors to the grounded circuit conductor, thus completing the ground-fault loop.
- It solidly ties the electrical system and its enclosures to their surroundings (usually earth, structural steel, and plumbing). This prevents voltages at any source from rising to harmfully high voltage-to-ground levels.

It should be noted that equipment grounding — bonding all electric equipment to ground — is required whether or not the system is grounded. System grounding should be handled by the electrical contractor installing the power feeds.

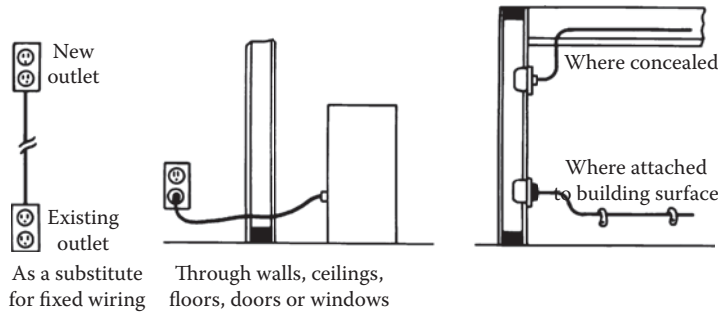


Figure 24.9 Flexible cord uses prohibited under NEC rules.

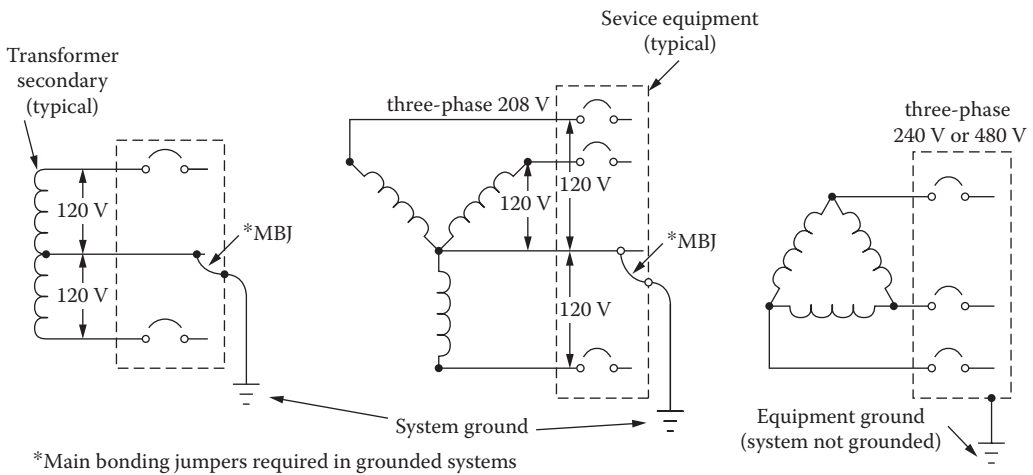


Figure 24.10 Even though regulations have been in place for many years, OSHA inspections still uncover violations in the grounding of primary electrical service systems.

Equipment grounding serves two important functions:

- It bonds all surfaces together so that there can be no voltage differences among them.
- It provides a ground-fault current path from a fault location back to the electrical source, so that if a fault current develops, it will operate the breaker, fuse, or GFCI.

The National Electrical Code is complex, and it contains numerous requirements concerning electrical safety. If the facility electric wiring system has gone through many changes over the years, have the entire system inspected by a qualified consultant. The fact sheets listed in Table 24.9 provide a good starting point for a self-evaluation. The fact sheets are available from any local OSHA office.

### 24.4.5 Management Responsibility

The key to operating a safe facility is diligent management. A carefully thought-out plan ensures a coordinated approach to protecting staff members from injury and the facility from potential litigation. Facilities that have effective accident-prevention programs follow seven basic guidelines. Although the details and overall organization may vary from workplace to workplace, these practices — summarized in Table 24.10 — still apply.

If managers are concerned about safety, it is likely that employees also will be. Display safety pamphlets, and recruit employee help in identifying hazards. Reward workers for good safety performance.

**Table 24.10** Major Points to Consider when Developing a Facility Safety Program

- 
- ✓ Management assumes the leadership role regarding safety policies.
  - ✓ Responsibility for safety- and health-related activities is clearly assigned.
  - ✓ Hazards are identified, and steps are taken to eliminate them.
  - ✓ Employees at all levels are trained in proper safety procedures.
  - ✓ Thorough accident/injury records are maintained.
  - ✓ Medical attention and first aid is readily available.
  - ✓ Employee awareness and participation is fostered through incentives and an ongoing, high-profile approach to workplace safety.
- 

Often, an incentive program will help to encourage safe work practices. Eliminate any hazards identified, and obtain OSHA forms and any first aid supplies that would be needed in an emergency. The OSHA *Handbook for Small Business* outlines the legal requirements imposed by the Occupational Safety and Health Act of 1970. The handbook, which is available from OSHA, also suggests ways in which a company can develop an effective safety program.

Free on-site consultations also are available from OSHA. A consultant will tour the facility and offer practical advice about safety. These consultants do not issue citations, propose penalties, or routinely provide information about workplace conditions to the federal inspection staff. Contact the nearest OSHA office for additional information. Table 24.11 provides a basic checklist of safety points for consideration.

**Table 24.11** Sample Checklist of Important Safety Items

---

Refer regularly to this checklist to maintain a safe facility. For each category shown, be sure that:

*Electrical Safety*

- ✓ Fuses of the proper size have been installed.
- ✓ All ac switches are mounted in clean, tightly closed metal boxes.
- ✓ Each electrical switch is marked to show its purpose.
- ✓ Motors are clean and free of excessive grease and oil.
- ✓ Motors are maintained properly and provided with adequate overcurrent protection.
- ✓ Bearings are in good condition.
- ✓ Portable lights are equipped with proper guards.
- ✓ All portable equipment is double-insulated or properly grounded.
- ✓ The facility electrical system is checked periodically by a contractor competent in the NEC.
- ✓ The equipment-grounding conductor or separate ground wire has been carried all the way back to the supply ground connection.
- ✓ All extension cords are in good condition, and the grounding pin is not missing or bent.
- ✓ Ground-fault interrupters are installed as required.

*Exits and Access*

- ✓ All exits are visible and unobstructed.
- ✓ All exits are marked with a readily visible, properly illuminated sign.
- ✓ There are sufficient exits to ensure prompt escape in the event of an emergency.

*Fire Protection*

- ✓ Portable fire extinguishers of the appropriate type are provided in adequate numbers.
  - ✓ All remote vehicles have proper fire extinguishers.
  - ✓ Fire extinguishers are inspected monthly for general condition and operability, which is noted on the inspection tag.
  - ✓ Fire extinguishers are mounted in readily accessible locations.
  - ✓ The fire alarm system is tested annually.
-

Maintaining safety standards is difficult in any size organization. A written safety manual that has specific practices and procedures for normal workplace hazards as well as the emergency-related hazards you identify is a good idea and may lower your insurance rates [4]. If outside workers set foot in your facility, prepare a special Safety Manual for Contractors. Include in it installation standards, compliance with *Lock-Out/Tag-Out*, and emergency contact names, and phone numbers. *Lock-Out/Tag-Out* is a set of standard safety policies that assure that energy is removed from equipment during installation and maintenance. It assures that every member of a work detail is clear before power is reapplied. Make sure outside contractors carry proper insurance and are qualified, licensed, or certified to do the work for which you contract.

## 24.5 References

---

1. Federal Information Processing Standards Publication No. 94, *Guideline on Electrical Power for ADP Installations*, U.S. Department of Commerce, National Bureau of Standards, Washington, DC, 1983.
2. *Practical Guide to Ground Fault Protection*, PRIMEDIA Intertec, Overland Park, KS, 1995.
3. National Electrical Code, NFPA no. 70.
4. Rudman, R., "Disaster Planning and Recovery," in *The Electronics Handbook*, 2nd ed., J. C. Whitaker (Ed.), CRC Press, Boca Raton, FL, 2005.

## 24.6 Bibliography

---

Code of Federal Regulations, 40, Part 761.

"Current Intelligence Bulletin #45," National Institute for Occupational Safety and Health Division of Standards Development and Technology Transfer, February 24, 1986.

"Electrical Standards Reference Manual," U.S. Department of Labor, Washington, DC.

Hammar, W., *Occupational Safety Management and Engineering*, Prentice-Hall, New York.

Lawrie, R., *Electrical Systems for Computer Installations*, McGraw-Hill, New York, 1988.

Pfrimmer, J., "Identifying and Managing PCBs in Broadcast Facilities," *NAB Engineering Conference Proceedings*, National Association of Broadcasters, Washington, DC, 1987.

"Occupational Injuries and Illnesses in the United States by Industry," OSHA Bulletin 2278, U.S. Department of Labor, Washington, DC, 1985.

OSHA, "Handbook for Small Business," U.S. Department of Labor, Washington, DC.

OSHA, "Electrical Hazard Fact Sheets," U.S. Department of Labor, Washington, DC, January 1987.

# 25

## Reference Data and Tables

---

### 25.1 Standard Electrical Units

---

Name	Symbol	Quantity
ampere	A	electric current
ampere per meter	A/m	magnetic field strength
ampere per square meter	A/m <sup>2</sup>	current density
becquerel	Bq	activity (of a radionuclide)
candela	cd	luminous intensity
coulomb	C	electric charge
coulomb per kilogram	C/kg	exposure (x and gamma rays)
coulomb per square meter	C/m <sup>2</sup>	electric flux density
cubic meter	m <sup>3</sup>	volume
cubic meter per kilogram	m <sup>3</sup> /kg	specific volume
degree Celsius	°C	Celsius temperature
farad	F	capacitance
farad per meter	F/m	permittivity
henry	H	inductance
henry per meter	H/m	permeability
hertz	Hz	frequency
joule	J	energy, work, quantity of heat
joule per cubic meter	J/m <sup>3</sup>	energy density
joule per Kelvin	J/K	heat capacity
joule per kilogram K	J/(kg·K)	specific heat capacity
joule per mole	J/mol	molar energy
Kelvin	K	thermodynamic temperature
kilogram	kg	mass
kilogram per cubic meter	kg/m <sup>3</sup>	density, mass density
lumen	lm	luminous flux
lux	lx	luminance
meter	m	length
meter per second	m/s	speed, velocity
meter per second squared	m/s <sup>2</sup>	acceleration
mole	mol	amount of substance
newton	N	force
newton per meter	N/m	surface tension
ohm	Ω	electrical resistance
pascal	Pa	pressure, stress
pascal second	Pa·s	dynamic viscosity
radian	rad	plane angle
radian per second	rad/s	angular velocity
radian per second squared	rad/s <sup>2</sup>	angular acceleration
second	s	time
siemens	S	electrical conductance

Name	Symbol	Quantity
square meter	m <sup>2</sup>	area
steradian	sr	solid angle
tesla	T	magnetic flux density
volt	V	electrical potential
volt per meter	V/m	electric field strength
watt	W	power, radiant flux
watt per meter Kelvin	W/(m•K)	thermal conductivity
watt per square meter	W/m <sup>2</sup>	heat (power) flux density
weber	Wb	magnetic flux

### 25.1.1 Standard Prefixes

Multiple	Prefix	Symbol
10 <sup>18</sup>	exa	E
10 <sup>15</sup>	peta	P
10 <sup>12</sup>	tera	T
10 <sup>9</sup>	giga	G
10 <sup>6</sup>	mega	M
10 <sup>3</sup>	kilo	k
10 <sup>2</sup>	hecto	h
10	deka	da
10 <sup>-1</sup>	deci	d
10 <sup>-2</sup>	centi	c
10 <sup>-3</sup>	milli	m
10 <sup>-6</sup>	micro	μ
10 <sup>-9</sup>	nano	n
10 <sup>-12</sup>	pico	p
10 <sup>-15</sup>	femto	f
10 <sup>-18</sup>	atto	a

### 25.1.2 Common Standard Units

Unit	Symbol
centimeter	cm
cubic centimeter	cm <sup>3</sup>
cubic meter per second	m <sup>3</sup> /s
gigahertz	GHz
gram	g
kilohertz	kHz
kilohm	kΩ
kilojoule	kJ
kilometer	km
kilovolt	kV
kilovoltampere	kVA
kilowatt	kW
megahertz	MHz
megavolt	MV
megawatt	MW
megohm	MΩ
microampere	μA
microfarad	μF
microgram	μg
microhenry	μH
microsecond	μs
microwatt	μW
milliampere	mA
milligram	mg
millihenry	mH
millimeter	mm
millisecond	ms
millivolt	mV
milliwatt	mW
nanoampere	nA
nanofarad	nF
nanometer	nm
nanosecond	ns
nanowatt	nW
picoampere	pA
picofarad	pF
picosecond	ps
picowatt	pW

## 25.2 Reference Tables

---

### 25.2.1 Power Conversion Factors

<u>dBm</u>	<u>dBw</u>	<u>Watts</u>	<u>Multiple</u>	<u>Prefix</u>
+150	+120	1,000,000,000,000	$10^{12}$	1 terawatt
+140	+110	100,000,000,000	$10^{11}$	100 gigawatts
+130	+100	10,000,000,000	$10^{10}$	10 gigawatts
+120	+90	1,000,000,000	$10^9$	1 gigawatt
+110	+80	100,000,000	$10^8$	100 megawatts
+100	+70	10,000,000	$10^7$	10 megawatts
+90	+60	1,000,000	$10^6$	1 megawatt
+80	+50	100,000	$10^5$	100 kilowatts
+70	+40	10,000	$10^4$	10 kilowatts
+60	+30	1,000	$10^3$	1 kilowatt
+50	+20	100	$10^2$	1 hectowatt
+40	+10	10	10	1 decawatt
+30	0	1	1	1 watt
+20	-10	0.1	$10^{-1}$	1 deciwatt
+10	-20	0.01	$10^{-2}$	1 centiwatt
0	-30	0.001	$10^{-3}$	1 milliwatt
-10	-40	0.0001	$10^{-4}$	100 microwatts
-20	-50	0.00001	$10^{-5}$	10 microwatts
-30	-60	0.000,001	$10^{-6}$	1 microwatt
-40	-70	0.0,000,001	$10^{-7}$	100 nanowatts
-50	-80	0.00,000,001	$10^{-8}$	10 nanowatts
-60	-90	0.000,000,001	$10^{-9}$	1 nanowatt
-70	-100	0.0,000,000,001	$10^{-10}$	100 picowatts
-80	-110	0.00,000,000,001	$10^{-11}$	10 picowatts
-90	-120	0.000,000,000,001	$10^{-12}$	1 picowatt



## 25.2.2 Standing Wave Ratio

SWR	Reflection Coefficient	Return Loss	Power Ratio	Percent Reflected
1.01:1	0.0050	46.1 dB	0.00002	0.002
1.02:1	0.0099	40.1 dB	0.00010	0.010
1.04:1	0.0196	34.2 dB	0.00038	0.038
1.06:1	0.0291	30.7 dB	0.00085	0.085
1.08:1	0.0385	28.3 dB	0.00148	0.148
1.10:1	0.0476	26.4 dB	0.00227	0.227
1.20:1	0.0909	20.8 dB	0.00826	0.826
1.30:1	0.1304	17.7 dB	0.01701	1.700
1.40:1	0.1667	15.6 dB	0.02778	2.800
1.50:1	0.2000	14.0 dB	0.04000	4.000
1.60:1	0.2308	12.7 dB	0.05325	5.300
1.70:1	0.2593	11.7 dB	0.06722	6.700
1.80:1	0.2857	10.9 dB	0.08163	8.200
1.90:1	0.3103	10.2 dB	0.09631	9.600
2.00:1	0.3333	9.5 dB	0.11111	11.100
2.20:1	0.3750	8.5 dB	0.14063	14.100
2.40:1	0.4118	7.7 dB	0.16955	17.000
2.60:1	0.4444	7.0 dB	0.19753	19.800
2.80:1	0.4737	6.5 dB	0.22438	22.400
3.00:1	0.5000	6.0 dB	0.25000	25.000
3.50:1	0.5556	5.1 dB	0.30864	30.900
4.00:1	0.6000	4.4 dB	0.36000	36.000
4.50:1	0.6364	3.9 dB	0.40496	40.500
5.00:1	0.6667	3.5 dB	0.44444	44.400
6.00:1	0.7143	2.9 dB	0.51020	51.000
7.00:1	0.7500	2.5 dB	0.56250	56.300
8.00:1	0.7778	2.2 dB	0.60494	60.500
9.00:1	0.8000	1.9 dB	0.64000	64.000
10.00:1	0.8182	1.7 dB	0.66942	66.900
15.00:1	0.8750	1.2 dB	0.76563	76.600
20.00:1	0.9048	0.9 dB	0.81859	81.900
30.00:1	0.9355	0.6 dB	0.87513	97.500
40.00:1	0.9512	0.4 dB	0.90482	90.500
50.00:1	0.9608	0.3 dB	0.92311	92.300

### 25.2.3 Specifications of Standard Copper Wire Sizes

Wire Size (AWG)	Diameter (mils)	Circular mil Area	Turns per Linear Inch <sup>1</sup>			Ohms per 100 ft <sup>2</sup>	Current- Carrying Capacity <sup>3</sup>	Diameter (mm)
			Enamel	SCE	DCC			
1	289.3	83810	—	—	—	0.1239	119.600	7.348
2	257.6	05370	—	—	—	0.1563	94.800	6.544
3	229.4	62640	—	—	—	0.1970	75.200	5.827
4	204.3	41740	—	—	—	0.2485	59.600	5.189
5	181.9	33100	—	—	—	0.3133	47.300	4.621
6	162.0	26250	—	—	—	0.3951	37.500	4.115
7	144.3	20820	—	—	—	0.4982	29.700	3.665
8	128.5	16510	7.6	—	7.1	0.6282	23.600	3.264
9	114.4	13090	8.6	—	7.8	0.7921	18.700	2.906
10	101.9	10380	9.6	9.1	8.9	0.9989	14.800	2.588
11	90.7	8234	10.7	—	9.8	1.2600	11.800	2.305
12	80.8	6530	12.0	11.3	10.9	1.5880	9.330	2.063
13	72.0	5178	13.5	—	12.8	2.0030	7.400	1.828
14	64.1	4107	15.0	14.0	13.8	2.5250	5.870	1.628
15	57.1	3257	16.8	—	14.7	3.1840	4.650	1.450
16	50.8	2583	18.9	17.3	16.4	4.0160	3.690	1.291
17	45.3	2048	21.2	—	18.1	5.0640	2.930	1.150
18	40.3	1624	23.6	21.2	19.8	6.3860	2.320	1.024
19	35.9	1288	26.4	—	21.8	8.0510	1.840	0.912
20	32.0	1022	29.4	25.8	23.8	10.1500	1.460	0.812
21	28.5	810	33.1	—	26.0	12.8000	1.160	0.723
22	25.3	642	37.0	31.3	30.0	16.1400	0.918	0.644
23	22.6	510	41.3	—	37.6	20.3600	0.728	0.573
24	20.1	404	46.3	37.6	35.6	25.6700	0.577	0.511
25	17.9	320	51.7	—	38.6	32.3700	0.458	0.455
26	15.9	254	58.0	46.1	41.8	40.8100	0.363	0.406
27	14.2	202	64.9	—	45.0	51.4700	0.288	0.361
28	12.6	160	72.7	54.6	48.5	64.9000	0.228	0.321
29	11.3	127	81.6	—	51.8	81.8300	0.181	0.286
30	10.0	101	90.5	64.1	55.5	103.2000	0.144	0.255
31	8.9	50	101.0	—	59.2	130.1000	0.114	0.227
32	8.0	63	113.0	74.1	61.6	164.1000	0.090	0.202
33	7.1	50	127.0	—	66.3	206.9000	0.072	0.180
34	6.3	40	143.0	86.2	70.0	260.9000	0.057	0.160
35	5.6	32	158.0	—	73.5	329.0000	0.045	0.143
36	5.0	25	175.0	103.1	77.0	414.8000	0.036	0.127
37	4.5	20	198.0	—	80.3	523.1000	0.028	0.113
38	4.0	16	224.0	116.3	83.6	659.6000	0.022	0.101
39	3.5	12	248.0	—	86.6	831.8000	0.018	0.090

1. Based on 25.4 mm.

2. Ohms per 1000 ft measured at 20°C.

3. Current-carrying capacity at 700 cm/amp.

**25.2.4 Celsius-to-Fahrenheit Conversion Table**

°Celsius	°Fahrenheit	°Celsius	°Fahrenheit
-50	-58	125	257
-45	-49	130	266
-40	-40	135	275
-35	-31	140	284
-30	-22	145	293
-25	-13	150	302
-20	4	155	311
-15	5	160	320
-10	14	165	329
-5	23	170	338
0	32	175	347
5	41	180	356
10	50	185	365
15	59	190	374
20	68	195	383
25	77	200	392
30	86	205	401
35	95	210	410
40	104	215	419
45	113	220	428
50	122	225	437
55	131	230	446
60	140	235	455
65	149	240	464
70	158	245	473
75	167	250	482
80	176	255	491
85	185	260	500
90	194	265	509
95	203	270	518
100	212	275	527
105	221	280	536
110	230	285	545
115	239	290	554
120	248	295	563

### 25.2.5 Inch-to-Millimeter Conversion Table

Inch	0	1/8	1/4	3/8	1/2	5/8	3/4	7/8	Inch
0	0.00	3.18	6.35	9.52	12.70	15.88	19.05	22.22	0
1	25.40	28.58	31.75	34.92	38.10	41.28	44.45	47.62	1
2	50.80	53.98	57.15	60.32	63.50	66.68	69.85	73.02	2
3	76.20	79.38	82.55	85.72	88.90	92.08	95.25	98.42	3
4	101.60	104.80	108.00	111.10	114.30	117.50	120.60	123.80	4
5	127.00	130.20	133.40	136.50	139.70	142.90	146.00	149.20	5
6	152.40	155.60	158.80	161.90	165.10	168.30	171.40	174.60	6
7	177.80	181.00	184.20	187.30	190.50	193.70	196.80	200.00	7
8	203.20	206.40	209.60	212.70	215.90	219.10	222.20	225.40	8
9	228.60	231.80	235.00	238.10	241.30	244.50	247.60	250.80	9
10	254.00	257.20	260.40	263.50	266.70	269.90	273.00	276.20	10
11	279.00	283.00	286.00	289.00	292.00	295.00	298.00	302.00	11
12	305.00	308.00	311.00	314.00	317.00	321.00	324.00	327.00	12
13	330.00	333.00	337.00	340.00	343.00	346.00	349.00	352.00	13
14	356.00	359.00	362.00	365.00	368.00	371.00	375.00	378.00	14
15	381.00	384.00	387.00	391.00	394.00	397.00	400.00	403.00	15
16	406.00	410.00	413.00	416.00	419.00	422.00	425.00	429.00	16
17	432.00	435.00	438.00	441.00	445.00	448.00	451.00	454.00	17
18	457.00	460.00	464.00	467.00	470.00	473.00	476.00	479.00	18
19	483.00	486.00	489.00	492.00	495.00	498.00	502.00	505.00	19
20	508.00	511.00	514.00	518.00	521.00	524.00	527.00	530.00	20

## 25.2.6 Conversion of Millimeters to Decimal Inches

mm	Inches	mm	Inches	mm	Inches
1	0.039370	46	1.811020	91	3.582670
2	0.078740	47	1.850390	92	3.622040
3	0.118110	48	1.889760	93	3.661410
4	0.157480	49	1.929130	94	3.700780
5	0.196850	50	1.968500	95	3.740150
6	0.236220	51	2.007870	96	3.779520
7	0.275590	52	2.047240	97	3.818890
8	0.314960	53	2.086610	98	3.858260
9	0.354330	54	2.125980	99	3.897630
10	0.393700	55	2.165350	100	3.937000
11	0.433070	56	2.204720	105	4.133848
12	0.472440	57	2.244090	110	4.330700
13	0.511810	58	2.283460	115	4.527550
14	0.551180	59	2.322830	120	4.724400
15	0.590550	60	2.362200	125	4.921250
16	0.629920	61	2.401570	210	8.267700
17	0.669290	62	2.440940	220	8.661400
18	0.708660	63	2.480310	230	9.055100
19	0.748030	64	2.519680	240	9.448800
20	0.787400	65	2.559050	250	9.842500
21	0.826770	66	2.598420	260	10.236200
22	0.866140	67	2.637790	270	10.629900
23	0.905510	68	2.677160	280	11.032600
24	0.944880	69	2.716530	290	11.417300
25	0.984250	70	2.755900	300	11.811000
26	1.023620	71	2.795270	310	12.204700
27	1.062990	72	2.834640	320	12.598400
28	1.102360	73	2.874010	330	12.992100
29	1.141730	74	2.913380	340	13.385800
30	1.181100	75	2.952750	350	13.779500
31	1.220470	76	2.992120	360	14.173200
32	1.259840	77	3.031490	370	14.566900
33	1.299210	78	3.070860	380	14.960600
34	1.338580	79	3.110230	390	15.354300
35	1.377949	80	3.149600	400	15.748000
36	1.417319	81	3.188970	500	19.685000
37	1.456689	82	3.228340	600	23.622000
38	1.496050	83	3.267710	700	27.559000
39	1.535430	84	3.307080	800	31.496000
40	1.574800	85	3.346450	900	35.433000
41	1.614170	86	3.385820	1000	39.370000
42	1.653540	87	3.425190	2000	78.740000
43	1.692910	88	3.464560	3000	118.110000
44	1.732280	89	3.503930	4000	157.480000
45	1.771650	90	3.543300	5000	196.850000

### 25.2.7 Conversion of Common Fractions to Decimal and Millimeter Units

Common Fractions	Decimal Fractions	mm (approx.)	Common Fractions	Decimal Fractions	mm (approx.)
1/128	0.008	0.20	1/2	0.500	12.70
1/64	0.016	0.40	33/64	0.516	13.10
1/32	0.031	0.79	17/32	0.531	13.49
3/64	0.047	1.19	35/64	0.547	13.89
1/16	0.063	1.59	9/16	0.563	14.29
5/64	0.078	1.98	37/64	0.578	14.68
3/32	0.094	2.38	19/32	0.594	15.08
7/64	0.109	2.78	39/64	0.609	15.48
1/8	0.125	3.18	5/8	0.625	15.88
9/64	0.141	3.57	41/64	0.641	16.27
5/32	0.156	3.97	21/32	0.656	16.67
11/64	0.172	4.37	43/64	0.672	17.07
3/16	0.188	4.76	11/16	0.688	17.46
13/64	0.203	5.16	45/64	0.703	17.86
7/32	0.219	5.56	23/32	0.719	18.26
15/64	0.234	5.95	47/64	0.734	18.65
1/4	0.250	6.35	3/4	0.750	19.05
17/64	0.266	6.75	49/64	0.766	19.45
9/32	0.281	7.14	25/32	0.781	19.84
19/64	0.297	7.54	51/64	0.797	20.24
5/16	0.313	7.94	13/16	0.813	20.64
21/64	0.328	8.33	53/64	0.828	21.03
11/32	0.344	8.73	27/32	0.844	21.43
23/64	0.359	9.13	55/64	0.859	21.83
3/8	0.375	9.53	7/8	0.875	22.23
25/64	0.391	9.92	57/64	0.891	22.62
13/32	0.406	10.32	29/32	0.906	23.02
27/64	0.422	10.72	59/64	0.922	23.42
7/16	0.438	11.11	15/16	0.938	23.81
29/64	0.453	11.51	61/64	0.953	24.21
15/32	0.469	11.91	31/32	0.969	24.61
31/64	0.484	12.30	63/64	0.984	25.00

### 25.2.8 Decimal Equivalent Size of Drill Numbers

Drill Number	Decimal Equivalent	Drill Number	Decimal Equivalent	Drill Number	Decimal Equivalent
80	0.0135	53	0.0595	26	0.1470
79	0.0145	52	0.0635	25	0.1495
78	0.0160	51	0.0670	24	0.1520
77	0.0180	50	0.0700	23	0.1540
76	0.0200	49	0.0730	22	0.1570
75	0.0210	48	0.0760	21	0.1590
74	0.0225	47	0.0785	20	0.1610
73	0.0240	46	0.0810	19	0.1660
72	0.0250	45	0.0820	18	0.1695
71	0.0260	44	0.0860	17	0.1730
70	0.0280	43	0.0890	16	0.1770
69	0.0292	42	0.0935	15	0.1800
68	0.0310	41	0.0960	14	0.1820
67	0.0320	40	0.0980	13	0.1850
66	0.0330	39	0.0995	12	0.1890
65	0.0350	38	0.1015	11	0.1910
64	0.0360	37	0.1040	10	0.1935
63	0.0370	36	0.1065	9	0.1960
62	0.0380	35	0.1100	8	0.1990
61	0.0390	34	0.1110	7	0.2010
60	0.0400	33	0.1130	6	0.2040
59	0.0410	32	0.1160	5	0.2055
58	0.0420	31	0.1200	4	0.2090
57	0.0430	30	0.1285	3	0.2130
56	0.0465	29	0.1360	2	0.2210
55	0.0520	28	0.1405	1	0.2280
54	0.0550	27	0.1440		

### 25.2.9 Decimal Equivalent Size of Drill Letters

Letter Drill	Decimal Equivalent	Letter Drill	Decimal Equivalent	Letter Drill	Decimal Equivalent
A	0.234	J	0.277	S	0.348
B	0.238	K	0.281	T	0.358
C	0.242	L	0.290	U	0.368
D	0.246	M	0.295	V	0.377
E	0.250	N	0.302	W	0.386
F	0.257	O	0.316	X	0.397
G	0.261	P	0.323	Y	0.404
H	0.266	Q	0.332	Z	0.413
I	0.272	R	0.339		

### 25.2.10 Conversion Ratios for Length

Known Quantity	Multiply by	Quantity to Find
inches (in)	2.54	centimeters (cm)
feet (ft)	30	centimeters (cm)
yards (yd)	0.9	meters (m)
miles (mi)	1.6	kilometers (km)
millimeters (mm)	0.04	inches (in.)
centimeters (cm)	0.4	inches (in.)
meters (m)	3.3	feet (ft)
meters (m)	1.1	yards (yd)
kilometers (km)	0.6	miles (mi)
centimeters (cm)	10	millimeters (mm)
decimeters (dm)	10	centimeters (cm)
decimeters (dm)	100	millimeters (mm)
meters (m)	10	decimeters (dm)
meters (m)	1000	millimeters (mm)
dekameters (dam)	10	meters (m)
hectometers (hm)	10	dekameters (dam)
hectometers (hm)	100	meters (m)
kilometers (km)	10	hectometers (hm)
kilometers (km)	1000	meters (m)

### 25.2.11 Conversion Ratios for Area

Known Quantity	Multiply by	Quantity to Find
square inches (in. <sup>2</sup> )	6.5	square centimeters (cm <sup>2</sup> )
square feet (ft <sup>2</sup> )	0.09	square meters (m <sup>2</sup> )
square yards (yd <sup>2</sup> )	0.8	square meters (m <sup>2</sup> )
square miles (mi <sup>2</sup> )	2.6	square kilometers (km <sup>2</sup> )
acres	0.4	hectares (ha)
square centimeters (cm <sup>2</sup> )	0.16	square inches (in. <sup>2</sup> )
square meters (m <sup>2</sup> )	1.2	square yards (yd <sup>2</sup> )
square kilometers (km <sup>2</sup> )	0.4	square miles (mi <sup>2</sup> )
hectares (ha)	2.5	acres
square centimeters (cm <sup>2</sup> )	100	square millimeters (mm <sup>2</sup> )
square meters (m <sup>2</sup> )	10,000	square centimeters (cm <sup>2</sup> )
square meters (m <sup>2</sup> )	1,000,000	square millimeters (mm <sup>2</sup> )
ares (a)	100	square meters (m <sup>2</sup> )
hectares (ha)	100	ares (a)
hectares (ha)	10,000	square meters (m <sup>2</sup> )
square kilometers (km <sup>2</sup> )	100	hectares (ha)
square kilometers (km <sup>2</sup> )	1,000	square meters (m <sup>2</sup> )



**25.2.12 Conversion Ratios for Mass**

Known Quantity	Multiply by	Quantity to Find
ounces (oz)	28	grams (g)
pounds (lb)	0.45	kilograms (kg)
tons	0.9	tonnes (t)
grams (g)	0.035	ounces (oz)
kilograms (kg)	2.2	pounds (lb)
tonnes (t)	100	kilograms (kg)
tonnes (t)	1.1	tons
centigrams (cg)	10	milligrams (mg)
decigrams (dg)	10	centigrams (cg)
decigrams (dg)	100	milligrams (mg)
grams (g)	10	decigrams (dg)
grams (g)	1000	milligrams (mg)
dekagram (dag)	10	grams (g)
hectogram (hg)	10	dekagrams (dag)
hectogram (hg)	100	grams (g)
kilograms (kg)	10	hectograms (hg)
kilograms (kg)	1000	grams (g)

**25.2.13 Conversion Ratios for Volume**

Known Quantity	Multiply by	Quantity to Find
milliliters (ml)	0.03	fluid ounces (fl oz)
liters (l)	2.1	pints (pt)
liters (l)	1.06	quarts (qt)
liters (l)	0.26	gallons (gal)
gallons (gal)	3.8	liters (l)
quarts (qt)	0.95	liters (l)
pints (pt)	0.47	liters (l)
cups (c)	0.24	liters (l)
fluid ounces (fl oz)	30	milliliters (ml)
teaspoons (tsp)	5	milliliters (ml)
tablespoons (tbsp)	15	milliliters (ml)
liters (l)	100	milliliters (ml)

### 25.2.14 Conversion Ratios for Cubic Measure

Known Quantity	Multiply by	Quantity to Find
cubic meters (m <sup>3</sup> )	35	cubic feet (ft <sup>3</sup> )
cubic meters (m <sup>3</sup> )	1.3	cubic yards (yd <sup>3</sup> )
cubic yards (yd <sup>3</sup> )	0.76	cubic meters (m <sup>3</sup> )
cubic feet (ft <sup>3</sup> )	0.028	cubic meters (m <sup>3</sup> )
cubic centimeters (cm <sup>3</sup> )	1000	cubic millimeters (mm <sup>3</sup> )
cubic decimeters (dm <sup>3</sup> )	1000	cubic centimeters (cm <sup>3</sup> )
cubic decimeters (dm <sup>3</sup> )	1,000,000	cubic millimeters (mm <sup>3</sup> )
cubic meters (m <sup>3</sup> )	1000	cubic decimeters (dm <sup>3</sup> )
cubic meters (m <sup>3</sup> )	1	steres
cubic feet (ft <sup>3</sup> )	1728	cubic inches (in. <sup>3</sup> )
cubic feet (ft <sup>3</sup> )	28.32	liters (l)
cubic inches (in. <sup>3</sup> )	16.39	cubic centimeters (cm <sup>3</sup> )
cubic meters (m <sup>3</sup> )	264	gallons (gal)
cubic yards (yd <sup>3</sup> )	27	cubic feet (ft <sup>3</sup> )
cubic yards (yd <sup>3</sup> )	202	gallons (gal)
gallons (gal)	231	cubic inches (in. <sup>3</sup> )

### 25.2.15 Conversion Ratios for Electrical Quantities

Known Quantity	Multiply by	Quantity to Find
Btu per minute	0.024	horsepower (hp)
Btu per minute	17.57	watts (W)
horsepower (hp)	33,000	foot-pounds per min (ft-lb/min)
horsepower (hp)	746	watts (W)
kilowatts (kW)	57	Btu per minute
kilowatts (kW)	1.34	horsepower (hp)

# 26

## Units Conversion Table

### 26.1 Quantity Conversion

To Convert	Into	Multiply by
abcoulomb	statcoulombs	$2.998 \times 10^{10}$
acre	sq. chain (Gunters)	10
acre	rods	160
acre	square links (Gunters)	$1 \times 10^5$
acre	Hectare or sq. hectometer	0.4047
acre-feet	cubic feet	43,560
acre-feet	gallons	$3.259 \times 10^5$
acres	sq. feet	43,560
acres	sq. meters	4,047
acres	sq. miles	$1.562 \times 10^{-3}$
acres	sq. yards	4,840
ampere-hours	coulombs	3,600
ampere-hours	faradays	0.03731
amperes/sq. cm	amps/sq. in.	6.452
amperes/sq. cm	amps/sq. meter	$10^4$
amperes/sq. in.	amps/sq. cm	0.1550
amperes/sq. in.	amps/sq. meter	1,550
amperes/sq. meter	amps/sq. cm	$10^{-4}$
amperes/sq. meter	amps/sq. in.	$6.452 \times 10^{-4}$
ampere-turns	gilberts	1.257
ampere-turns/cm	amp-turns/in.	2.540
ampere-turns/cm	amp-turns/meter	100
ampere-turns/cm	gilberts/cm	1.257
ampere-turns/in.	amp-turns/cm	0.3937
ampere-turns/in.	amp-turns/m	39.37
ampere-turns/in.	gilberts/cm	0.4950
ampere-turns/meter	amp-turns/cm	0.01
ampere-turns/meter	amp-turns/in.	0.0254
ampere-turns/meter	gilberts/cm	0.01257
Angstrom unit	in.	$3937 \times 10^{-9}$
Angstrom unit	meters	$1 \times 10^{-10}$
Angstrom unit	micron or ( $\mu$ )	$1 \times 10^{-4}$
are	acres (U.S.)	0.02471
ares	sq. yards	119.60
ares	acres	0.02471
ares	sq. meters	100
astronomical unit	kilometers	$1.495 \times 10^8$
atmospheres	ton/sq. in.	0.007348
atmospheres	cm of mercury	76.0
atmospheres	ft of water (at 4°C)	33.90
atmospheres	in. of mercury (at 0°C)	29.92
atmospheres	kg/sq. cm	1.0333
atmospheres	kg/sq. m	10,332
atmospheres	pounds/sq. in.	14.70
atmospheres	tons/sq. ft	1.058
barrels (U.S., dry)	cubic in.	7056
barrels (U.S., dry)	quarts (dry)	105

To Convert	Into	Multiply by
barrels (U.S., liquid)	gallons	31.5
barrels (oil)	gallons (oil)	42.0
bars	atmospheres	0.9869
bars	dynes/sq. cm	$10^4$
bars	kg/sq. m	$1.020 \times 10^4$
bars	pounds/sq. ft	2,089
bars	pounds/sq. in.	14.50
baryl	dyne/sq. cm	1.000
bolt (U.S. cloth)	meters	36.576
Btu	liter-atmosphere	10.409
Btu	ergs	$1.0550 \times 10^{10}$
Btu	foot-pounds	778.3
Btu	gram-calories	252.0
Btu	horsepower-hr	$3.931 \times 10^{-4}$
Btu	joules	1,054.8
Btu	kilogram-calories	0.2520
Btu	kilogram-meters	107.5
Btu	kilowatt-hr	$2.928 \times 10^{-4}$
Btu/hr	foot-pounds/s	0.2162
Btu/hr	gram-calories/s	0.0700
Btu/hr	horsepower-hr	$3.929 \times 10^{-4}$
Btu/hr	watts	0.2931
Btu/min	foot-lb/s	12.96
Btu/min	horsepower	0.02356
Btu/min	kilowatts	0.01757
Btu/min	watts	17.57
Btu/sq. ft/min	watts/sq. in.	0.1221
bucket (br. dry)	cubic cm	$1.818 \times 10^4$
bushels	cubic ft	1.2445
bushels	cubic in.	2,150.4
bushels	cubic m	0.03524
bushels	liters	35.24
bushels	pecks	4.0
bushels	pints (dry)	64.0
bushels	quarts (dry)	32.0
calories, gram (mean)	Btu (mean)	$3.9685 \times 10^{-3}$
candle/sq. cm	Lamberts	3.142
candle/sq. in.	Lamberts	0.4870
centares (centiares)	sq. meters	1.0
Centigrade	Fahrenheit	$(C^\circ \times 9/5) + 32$
centigrams	grams	0.01
centiliter	ounce fluid (U.S.)	0.3382
centiliter	cubic in.	0.6103
centiliter	drams	2.705
centiliter	liters	0.01
centimeter	feet	$3.281 \times 10^{-2}$
centimeter	inches	0.3937
centimeter	kilometers	$10^{-5}$
centimeter	meters	0.01
centimeter	miles	$6.214 \times 10^{-6}$
centimeter	millimeters	10.0
centimeter	mils	393.7
centimeter	yards	$1.094 \times 10^{-2}$
centimeter-dynes	cm-grams	$1.020 \times 10^{-3}$
centimeter-dynes	meter-kg	$1.020 \times 10^{-8}$
centimeter-dynes	pound-ft	$7.376 \times 10^{-8}$
centimeter-grams	cm-dynes	980.7
centimeter-grams	meter-kg	$10^{-5}$
centimeter-grams	pound-ft	$7.233 \times 10^{-5}$

To Convert	Into	Multiply by
centimeters of mercury	atmospheres	0.01316
centimeters of mercury	feet of water	0.4461
centimeters of mercury	kg/sq. meter	136.0
centimeters of mercury	pounds/sq. ft	27.85
centimeters of mercury	pounds/sq. in.	0.1934
centimeters/sec	feet/min	1.9686
centimeters/sec	feet/sec	0.03281
centimeters/sec	kilometers/hr	0.036
centimeters/sec	knots	0.1943
centimeters/sec	meters/min	0.6
centimeters/sec	miles/hr	0.02237
centimeters/sec	miles/min	$3.728 \times 10^{-4}$
centimeters/sec/sec	feet/sec/sec	0.03281
centimeters/sec/sec	km/hr/sec	0.036
centimeters/sec/sec	meters/sec/sec	0.01
centimeters/sec/sec	miles/hr/sec	0.02237
chain	in.	792.00
chain	meters	20.12
chains (surveyor's or Gunter's)	yards	22.00
circular mils	sq. cm	$5.067 \times 10^{-6}$
circular mils	sq. mils	0.7854
circular mils	sq. in.	$7.854 \times 10^{-7}$
circumference	radians	6.283
cord feet	cubic feet	16
cords	cord feet	8
coulomb	statcoulombs	$2.998 \times 10^9$
coulombs	faradays	$1.036 \times 10^{-5}$
coulombs/sq. cm	coulombs/sq. in.	64.52
coulombs/sq. cm	coulombs/sq. meter	$10^4$
coulombs/sq. in.	coulombs/sq. cm	0.1550
coulombs/sq. in.	coulombs/sq. meter	1,550
coulombs/sq. meter	coulombs/sq. cm	$10^{-4}$
coulombs/sq. meter	coulombs/sq. in.	$6.452 \times 10^{-4}$
cubic centimeters	cubic feet	$3.531 \times 10^{-5}$
cubic centimeters	cubic in.	0.06102
cubic centimeters	cubic meters	$10^{-6}$
cubic centimeters	cubic yards	$1.308 \times 10^{-6}$
cubic centimeters	gallons (U.S. liq.)	$2.642 \times 10^{-4}$
cubic centimeters	liters	0.001
cubic centimeters	pints (U.S. liq.)	$2.113 \times 10^{-3}$
cubic centimeters	quarts (U.S. liq.)	$1.057 \times 10^{-3}$
cubic feet	bushels (dry)	0.8036
cubic feet	cubic cm	28,320.0
cubic feet	cubic in.	1,728.0
cubic feet	cubic meters	0.02832
cubic feet	cubic yards	0.03704
cubic feet	gallons (U.S. liq.)	7.48052
cubic feet	liters	28.32
cubic feet	pints (U.S. liq.)	59.84
cubic feet	quarts (U.S. liq.)	29.92
cubic feet/min	cubic cm/sec	472.0
cubic feet/min	gallons/sec	0.1247
cubic feet/min	liters/sec	0.4720
cubic feet/min	pounds of water/min	62.43
cubic feet/sec	million gal/day	0.646317
cubic feet/sec	gallons/min	448.831
cubic in.	cubic cm	16.39
cubic in.	cubic feet	$5.787 \times 10^{-4}$
cubic in.	cubic meters	$1.639 \times 10^{-5}$

To Convert	Into	Multiply by
cubic in.	cubic yards	$2.143 \times 10^{-5}$
cubic in.	gallons	$4.329 \times 10^{-3}$
cubic in.	liters	0.01639
cubic in.	mil-feet	$1.061 \times 10^5$
cubic in.	pints (U.S. liq.)	0.03463
cubic in.	quarts (U.S. liq.)	0.01732
cubic in.	bushels (dry)	28.38
cubic in.	cubic cm	$10^6$
cubic in.	cubic feet	35.31
cubic in.	cubic in.	61,023.0
cubic in.	cubic yards	1.308
cubic in.	gallons (U.S. liq.)	264.2
cubic in.	liters	1,000
cubic in.	pints (U.S. liq.)	2,113
cubic in.	quarts (U.S. liq.)	1,057
cubic yards	cubic cm	$7.646 \times 10^5$
cubic yards	cubic feet	27.0
cubic yards	cubic in.	46,656.0
cubic yards	cubic meters	0.7646
cubic yards	gallons (U.S. liq.)	202.0
cubic yards	liters	764.6
cubic yards	pints (U.S. liq.)	1,615.9
cubic yards	quarts (U.S. liq.)	807.9
cubic yards/min	cubic ft/sec	0.45
cubic yards/min	gallons/sec	3.367
cubic yards/min	liters/sec	12.74
Dalton	grams	$1.650 \times 10^{-24}$
days	seconds	86,400
decigrams	grams	0.1
deciliters	liters	0.1
decimeters	meters	0.1
degrees (angle)	quadrants	0.01111
degrees (angle)	radians	0.01745
degrees (angle)	seconds	3,600
degrees/sec	radians/sec	0.01745
degrees/sec	revolutions/min	0.1667
degrees/sec	revolutions/sec	$2.778 \times 10^{-3}$
dekagrams	grams	10
dekaliters	liters	10
dekameters	meters	10
drams (apothecaries or troy)	ounces (avdp.)	0.1371429
drams (apothecaries or troy)	ounces (troy)	0.125
drams (U.S., fluid or apothecaries)	cubic cm	3.6967
drams	grams	1.7718
drams	grains	27.3437
drams	ounces	0.0625
dyne/cm	erg/sq. millimeter	0.01
dyne/sq. cm	atmospheres	$9.869 \times 10^{-7}$
dyne/sq. cm	in. of mercury at 0°C	$2.953 \times 10^{-5}$
dyne/sq. cm	in. of water at 4°C	$4.015 \times 10^{-4}$
dynes	grams	$1.020 \times 10^{-3}$
dynes	joules/cm	$10^{-7}$
dynes	joules/meter (newtons)	$10^{-5}$
dynes	kilograms	$1.020 \times 10^{-6}$
dynes	poundals	$7.233 \times 10^{-5}$
dynes	pounds	$2.248 \times 10^{-6}$
dynes/sq. cm	bars	$10^{-6}$
ell	cm	114.30
ell	in.	45

To Convert	Into	Multiply by
em, pica	in.	0.167
em, pica	cm	0.4233
erg/sec	Dyne-cm/sec	1.000
ergs	Btu	$9.480 \times 10^{-11}$
ergs	dyne-centimeters	1.0
ergs	foot-pounds	$7.367 \times 10^{-8}$
ergs	gram-calories	$0.2389 \times 10^{-7}$
ergs	gram-cm	$1.020 \times 10^{-3}$
ergs	horsepower-hr	$3.7250 \times 10^{-14}$
ergs	joules	$10^{-7}$
ergs	kg-calories	$2.389 \times 10^{-11}$
ergs	kg-meters	$1.020 \times 10^{-8}$
ergs	kilowatt-hr	$0.2778 \times 10^{-13}$
ergs	watt-hr	$0.2778 \times 10^{-10}$
ergs/sec	Btu/min	$5.688 \times 10^{-9}$
ergs/sec	ft-lb/min	$4.427 \times 10^{-6}$
ergs/sec	ft-lb/sec	$7.3756 \times 10^{-8}$
ergs/sec	horsepower	$1.341 \times 10^{-10}$
ergs/sec	kg-calories/min	$1.433 \times 10^{-9}$
ergs/sec	kilowatts	$10^{-10}$
farad	microfarads	$10^6$
faraday/sec	ampere (absolute)	$9.6500 \times 10^4$
faradays	ampere-hr	26.80
faradays	coulombs	$9.649 \times 10^4$
fathom	meters	1.828804
fathoms	feet	6.0
feet	centimeters	30.48
feet	kilometers	$3.048 \times 10^{-4}$
feet	meters	0.3048
feet	miles (naut.)	$1.645 \times 10^{-4}$
feet	miles (stat.)	$1.894 \times 10^{-4}$
feet	millimeters	304.8
feet	mils	$1.2 \times 10^4$
feet of water	atmospheres	0.02950
feet of water	in. of mercury	0.8826
feet of water	kg/sq. cm	0.03048
feet of water	kg/sq. meter	304.8
feet of water	pounds/sq. ft	62.43
feet of water	pounds/sq. in.	0.4335
feet/min	cm/sec	0.5080
feet/min	feet/sec	0.01667
feet/min	km/hr	0.01829
feet/min	meters/min	0.3048
feet/min	miles/hr	0.01136
feet/sec	cm/sec	30.48
feet/sec	km/hr	1.097
feet/sec	knots	0.5921
feet/sec	meters/min	18.29
feet/sec	miles/hr	0.6818
feet/sec	miles/min	0.01136
feet/sec/sec	cm/sec/sec	30.48
feet/sec/sec	km/hr/sec	1.097
feet/sec/sec	meters/sec/sec	0.3048
feet/sec/sec	miles/hr/sec	0.6818
feet/100 feet	per centigrade	1.0
foot-candle	lumen/sq. meter	10.764
foot-pounds	Btu	$1.286 \times 10^{-3}$
foot-pounds	ergs	$1.356 \times 10^7$
foot-pounds	gram-calories	0.3238

To Convert	Into	Multiply by
foot-pounds	hp-hr	$5.050 \times 10^{-7}$
foot-pounds	joules	1.356
foot-pounds	kg-calories	$3.24 \times 10^{-4}$
foot-pounds	kg-meters	0.1383
foot-pounds	kilowatt-hr	$3.766 \times 10^{-7}$
foot-pounds/min	Btu/min	$1.286 \times 10^{-3}$
foot-pounds/min	foot-pounds/sec	0.01667
foot-pounds/min	horsepower	$3.030 \times 10^{-5}$
foot-pounds/min	kg-calories/min	$3.24 \times 10^{-4}$
foot-pounds/min	kilowatts	$2.260 \times 10^{-5}$
foot-pounds/sec	Btu/hr	4.6263
foot-pounds/sec	Btu/min	0.07717
foot-pounds/sec	horsepower	$1.818 \times 10^{-3}$
foot-pounds/sec	kg-calories/min	0.01945
foot-pounds/sec	kilowatts	$1.356 \times 10^{-3}$
furlongs	miles (U.S.)	0.125
furlongs	rods	40.0
furlongs	feet	660.0
gallons	cubic cm	3,785.0
gallons	cubic feet	0.1337
gallons	cubic in.	231.0
gallons	cubic meters	$3.785 \times 10^{-3}$
gallons	cubic yards	$4.951 \times 10^{-3}$
gallons	liters	3.785
gallons (liq. Br. Imp.)	gallons (U.S. liq.)	1.20095
gallons (U.S.)	gallons (Imp.)	0.83267
gallons of water	pounds of water	8.3453
gallons/min	cubic ft/sec	$2.228 \times 10^{-3}$
gallons/min	liters/sec	0.06308
gallons/min	cubic ft/hr	8.0208
gausses	lines/sq. in.	6.452
gausses	webers/sq. cm	$10^{-8}$
gausses	webers/sq. in.	$6.452 \times 10^{-8}$
gausses	webers/sq. meter	$10^{-4}$
gilberts	ampere-turns	0.7958
gilberts/cm	amp-turns/cm	0.7958
gilberts/cm	amp-turns/in.	2.021
gilberts/cm	amp-turns/meter	79.58
gills	liters	0.1183
gills	pints (liq.)	0.25
gills (British)	cubic cm	142.07
grade	radian	0.01571
grains	drams (avdp.)	0.03657143
grains (troy)	grains (avdp.)	1.0
grains (troy)	grams	0.06480
grains (troy)	ounces (avdp.)	$2.0833 \times 10^{-3}$
grains (troy)	pennyweight (troy)	0.04167
grains/Imp. gal	parts/million	14.286
grains/U.S. gal	parts/million	17.118
grains/U.S. gal	pounds/million gal	142.86
gram-calories	Btu	$3.9683 \times 10^{-3}$
gram-calories	ergs	$4.1868 \times 10^7$
gram-calories	foot-pounds	3.0880
gram-calories	horsepower-hr	$1.5596 \times 10^{-6}$
gram-calories	kilowatt-hr	$1.1630 \times 10^{-6}$
gram-calories	watt-hr	$1.1630 \times 10^{-3}$
gram-calories/sec	Btu/hr	14.286
gram-centimeters	Btu	$9.297 \times 10^{-8}$
gram-centimeters	ergs	980.7



To Convert	Into	Multiply by
gram-centimeters	joules	$9.807 \times 10^{-5}$
gram-centimeters	kg-calories	$2.343 \times 10^{-8}$
gram-centimeters	kg-meters	$10^{-5}$
grams	dynes	980.7
grams	grains	15.43
grams	joules/cm	$9.807 \times 10^{-5}$
grams	joules/meter (newtons)	$9.807 \times 10^{-3}$
grams	kilograms	0.001
grams	milligrams	1,000
grams	ounces (avdp.)	0.03527
grams	ounces (troy)	0.03215
grams	poundals	0.07093
grams	pounds	$2.205 \times 10^{-3}$
grams/cm	pounds/in.	$5.600 \times 10^{-3}$
grams/cubic cm	pounds/cubic ft	62.43
grams/cubic cm	pounds/cubic in.	0.03613
grams/cubic cm	pounds/mil-foot	$3.405 \times 10^{-7}$
grams/liter	grains/gal	58.417
grams/liter	pounds/1,000 gal	8.345
grams/liter	pounds/cubic ft	0.062427
grams/liter	parts/million	1,000.0
grams/sq. cm	pounds/sq. ft	2.0481
hand	cm	10.16
hectares	acres	2.471
hectares	sq. feet	$1.076 \times 10^5$
hectograms	grams	100
hectoliters	liters	100
hectometers	meters	100
hectowatts	watts	100
henrys	millihenrys	1,000
horsepower	Btu/min	42.44
horsepower	foot-lb/min	33,000
horsepower	foot-lb/sec	550
horsepower	kg-calories/min	10.68
horsepower	kilowatts	0.7457
horsepower	watts	745.7
horsepower (boiler)	Btu/hr	33.479
horsepower (boiler)	kilowatts	9.803
horsepower, metric (542.5 ft lb./sec)	horsepower (550 ft lb./sec)	0.9863
horsepower (550 ft lb./sec)	horsepower, metric (542.5 ft lb./sec)	1.014
horsepower-hr	Btu	2,547
horsepower-hr	ergs	$2.6845 \times 10^{13}$
horsepower-hr	foot-lb	$1.98 \times 10^6$
horsepower-hr	gram-calories	641,190
horsepower-hr	joules	$2.684 \times 10^6$
horsepower-hr	kg-calories	641.1
horsepower-hr	kg-meters	$2.737 \times 10^5$
horsepower-hr	kilowatt-hr	0.7457
hours	days	$4.167 \times 10^{-2}$
hours	weeks	$5.952 \times 10^{-3}$
hundredweights (long)	pounds	112
hundredweights (long)	tons (long)	0.05
hundredweights (short)	ounces (avdp.)	1,600
hundredweights (short)	pounds	100
hundredweights (short)	tons (metric)	0.0453592
hundredweights (short)	tons (long)	0.0446429
in.	centimeters	2.540
in.	meters	$2.540 \times 10^{-2}$
in.	miles	$1.578 \times 10^{-5}$

To Convert	Into	Multiply by
in.	millimeters	25.40
in.	mils	1,000.0
in.	yards	$2.778 \times 10^{-2}$
in. of mercury	atmospheres	0.03342
in. of mercury	feet of water	1.133
in. of mercury	kg/sq. cm	0.03453
in. of mercury	kg/sq. meter	345.3
in. of mercury	pounds/sq. ft	70.73
in. of mercury	pounds/sq. in.	0.4912
in. of water (at 4°C)	atmospheres	$2.458 \times 10^{-3}$
in. of water (at 4°C)	in. of mercury	0.07355
in. of water (at 4°C)	kg/sq. cm	$2.540 \times 10^{-3}$
in. of water (at 4°C)	ounces/sq. in.	0.5781
in. of water (at 4°C)	pounds/sq. ft	5.204
in. of water (at 4°C)	pounds/sq. in.	0.03613
international ampere	amperes (absolute)	0.9998
international Volt	volts (absolute)	1.0003
international volt	joules (absolute)	$1.593 \times 10^{-19}$
international volt	joules	$9.654 \times 10^4$
joules	Btu	$9.480 \times 10^{-4}$
joules	ergs	$10^7$
joules	foot-pounds	0.7376
joules	kg-calories	$2.389 \times 10^{-4}$
joules	kg-meters	0.1020
joules	watt-hr	$2.778 \times 10^{-4}$
joules/cm	grams	$1.020 \times 10^4$
joules/cm	dynes	$10^7$
joules/cm	joules/meter (newtons)	100.0
joules/cm	poundals	723.3
joules/cm	pounds	22.48
kilogram-calories	Btu	3.968
kilogram-calories	foot-pounds	3,088
kilogram-calories	hp-hr	$1.560 \times 10^{-3}$
kilogram-calories	joules	4,186
kilogram-calories	kg-meters	426.9
kilogram-calories	kilojoules	4.186
kilogram-calories	kilowatt-hr	$1.163 \times 10^{-3}$
kilogram meters	Btu	$9.294 \times 10^{-3}$
kilogram meters	ergs	$9.804 \times 10^7$
kilogram meters	foot-pounds	7.233
kilogram meters	joules	9.804
kilogram meters	kg-calories	$2.342 \times 10^{-3}$
kilogram meters	kilowatt-hr	$2.723 \times 10^{-6}$
kilograms	dynes	980,665
kilograms	grams	1,000.0
kilograms	joules/cm	0.09807
kilograms	joules/meter (newtons)	9.807
kilograms	poundals	70.93
kilograms	pounds	2.205
kilograms	tons (long)	$9.842 \times 10^{-4}$
kilograms	tons (short)	$1.102 \times 10^{-3}$
kilograms/cubic meter	grams/cubic cm	0.001
kilograms/cubic meter	pounds/cubic ft	0.06243
kilograms/cubic meter	pounds/cubic in.	$3.613 \times 10^{-5}$
kilograms/cubic meter	pounds/mil-foot	$3.405 \times 10^{-10}$
kilograms/meter	pounds/ft	0.6720
kilograms/sq. cm	dynes	980,665
kilograms/sq. cm	atmospheres	0.9678
kilograms/sq. cm	feet of water	32.81

To Convert	Into	Multiply by
kilograms/sq. cm	in. of mercury	28.96
kilograms/sq. cm	pounds/sq. ft	2,048
kilograms/sq. cm	pounds/sq. in.	14.22
kilograms/sq. meter	atmospheres	$9.678 \times 10^{-5}$
kilograms/sq. meter	bars	$98.07 \times 10^{-6}$
kilograms/sq. meter	feet of water	$3.281 \times 10^{-3}$
kilograms/sq. meter	in. of mercury	$2.896 \times 10^{-3}$
kilograms/sq. meter	pounds/sq. ft	0.2048
kilograms/sq. meter	pounds/sq. in.	$1.422 \times 10^{-3}$
kilograms/sq. mm	kg/sq. meter	$10^6$
kilolines	maxwells	1,000
kiloliters	liters	1,000
kilometers	centimeters	$10^5$
kilometers	feet	3,281
kilometers	in.	$3.937 \times 10^4$
kilometers	meters	1,000
kilometers	miles	0.6214
kilometers	millimeters	$10^4$
kilometers	yards	1,094
kilometers/hr	cm/sec	27.78
kilometers/hr	feet/min	54.68
kilometers/hr	feet/sec	0.9113
kilometers/hr	knots	0.5396
kilometers/hr	meters/min	16.67
kilometers/hr	miles/hr	0.6214
kilometers/hr/sec	cm/sec/sec	27.78
kilometers/hr/sec	feet/sec/sec	0.9113
kilometers/hr/sec	meters/sec/sec	0.2778
kilometers/hr/sec	miles/hr/sec	0.6214
kilowatt-hr	Btu	3,413
kilowatt-hr	ergs	$3.600 \times 10^{13}$
kilowatt-hr	foot-lb	$2.655 \times 10^6$
kilowatt-hr	gram-calories	859,850
kilowatt-hr	horsepower-hr	1.341
kilowatt-hr	joules	$3.6 \times 10^6$
kilowatt-hr	kg-calories	860.5
kilowatt-hr	kg-meters	$3.671 \times 10^5$
kilowatt-hr	pounds of water raised from 62° to 212°F	22.75
kilowatts	Btu/min	56.92
kilowatts	foot-lb/min	$4.426 \times 10^4$
kilowatts	foot-lb/sec	737.6
kilowatts	horsepower	1.341
kilowatts	kg-calories/min	14.34
kilowatts	watts	1,000.0
knots	feet/hr	6,080
knots	kilometers/hr	1.8532
knots	nautical miles/hr	1.0
knots	statute miles/hr	1.151
knots	yards/hr	2,027
knots	feet/sec	1.689
league	miles (approx.)	3.0
light year	miles	$5.9 \times 10^{12}$
light year	kilometers	$9.4637 \times 10^{12}$
lines/sq. cm	gausses	1.0
lines/sq. in.	gausses	0.1550
lines/sq. in.	webers/sq. cm	$1.550 \times 10^{-9}$
lines/sq. in.	webers/sq. in.	$10^{-8}$
lines/sq. in.	webers/sq. meter	$1.550 \times 10^{-5}$
links (engineer's)	in.	12.0

To Convert	Into	Multiply by
links (surveyor's)	in.	7.92
liters	bushels (U.S. dry)	0.02838
liters	cubic cm	1,000
liters	cubic feet	0.03531
liters	cubic in.	61.02
liters	cubic meters	0.001
liters	cubic yards	$1.308 \times 10^{-3}$
liters	gallons (U.S. liq.)	0.2642
liters	pints (U.S. liq.)	2.113
liters	quarts (U.S. liq.)	1.057
liters/min	cubic ft/sec	$5.886 \times 10^{-4}$
liters/min	gal/sec	$4.403 \times 10^{-3}$
lumen	spherical candle power	0.07958
lumen	watts	0.001496
lumens/sq. ft	foot-candles	1.0
lumens/sq. ft	lumen/sq. meter	10.76
lux	foot-candles	0.0929
maxwells	kilolines	0.001
maxwells	webers	$10^{-8}$
megalines	maxwells	$10^6$
megohms	microhms	$10^{12}$
megohms	ohms	$10^6$
meter-kilograms	cm-dynes	$9.807 \times 10^7$
meter-kilograms	cm-grams	$10^5$
meter-kilograms	pound-feet	7.233
meters	centimeters	100
meters	feet	3.281
meters	in.	39.37
meters	kilometers	0.001
meters	miles (naut.)	$5.396 \times 10^{-4}$
meters	miles (stat.)	$6.214 \times 10^{-4}$
meters	millimeters	1,000
meters	yards	1.094
meters	varas	1.179
meters/min	cm/sec	1,667
meters/min	feet/min	3.281
meters/min	feet/sec	0.05468
meters/min	km/hr	0.06
meters/min	knots	0.03238
meters/min	miles/hr	0.03728
meters/sec	feet/min	196.8
meters/sec	feet/sec	3.281
meters/sec	kilometers/hr	3.6
meters/sec	kilometers/min	0.06
meters/sec	miles/hr	2.237
meters/sec	miles/min	0.03728
meters/sec/sec	cm/sec/sec	100
meters/sec/sec	ft/sec/sec	3.281
meters/sec/sec	km/hr/sec	3.6
meters/sec/sec	miles/hr/sec	2.237
microfarad	farads	$10^{-6}$
micrograms	grams	$10^{-6}$
microhms	megohms	$10^{-12}$
microhms	ohms	$10^{-6}$
microliters	liters	$10^{-6}$
microns	meters	$1 \times 10^{-6}$
miles (naut.)	feet	6,080.27
miles (naut.)	kilometers	1.853
miles (naut.)	meters	1,853

To Convert	Into	Multiply by
miles (naut.)	miles (statute)	1.1516
miles (naut.)	yards	2,027
miles (statute)	centimeters	$1.609 \times 10^5$
miles (statute)	feet	5,280
miles (statute)	in.	$6.336 \times 10^4$
miles (statute)	kilometers	1.609
miles (statute)	meters	1,609
miles (statute)	miles (naut.)	0.8684
miles (statute)	yards	1,760
miles/hr	cm/sec	44.70
miles/hr	feet/min	88
miles/hr	feet/sec	1.467
miles/hr	km/hr	1.609
miles/hr	km/min	0.02682
miles/hr	knots	0.8684
miles/hr	meters/min	26.82
miles/hr	miles/min	0.1667
miles/hr/sec	cm/sec/sec	44.70
miles/hr/sec	feet/sec/sec	1.467
miles/hr/sec	km/hr/sec	1.609
miles/hr/sec	meters/sec/sec	0.4470
miles/min	cm/sec	2,682
miles/min	feet/sec	88
miles/min	km/min	1.609
miles/min	knots/min	0.8684
miles/min	miles/hr	60
mil-feet	cubic in.	$9.425 \times 10^{-6}$
milliers	kilograms	1,000
milligrams	grains	0.01543236
milligrams	grams	0.001
milligrams/liter	parts/million	1.0
millihenrys	henrys	0.001
milliliters	liters	0.001
millimeters	centimeters	0.1
millimeters	feet	$3.281 \times 10^{-3}$
millimeters	in.	0.03937
millimeters	kilometers	$10^{-6}$
millimeters	meters	0.001
millimeters	miles	$6.214 \times 10^{-7}$
millimeters	mils	39.37
millimeters	yards	$1.094 \times 10^{-3}$
millimicrons	meters	$1 \times 10^{-9}$
million gal/day	cubic ft/sec	1.54723
mils	centimeters	$2.540 \times 10^{-3}$
mils	feet	$8.333 \times 10^{-5}$
mils	in.	0.001
mils	kilometers	$2.540 \times 10^{-8}$
mils	yards	$2.778 \times 10^{-5}$
miner's inches	cubic ft/min	1.5
minims (British)	cubic cm	0.059192
minims (U.S., fluid)	cubic cm	0.061612
minutes (angles)	degrees	0.01667
minutes (angles)	quadrants	$1.852 \times 10^{-4}$
minutes (angles)	radians	$2.909 \times 10^{-4}$
minutes (angles)	seconds	60
myriagrams	kilograms	10
myriameters	kilometers	10
myriawatts	kilowatts	10
nepers	decibels	8.686

To Convert	Into	Multiply by
Newton	dynes	$1 \times 10^5$
ohms (international)	ohm (absolute)	1.0005
ohms	megohms	$10^{-6}$
ohms	microhms	$10^6$
ounces	drams	16.0
ounces	grains	437.5
ounces	grams	28.349527
ounces	pounds	0.0625
ounces	ounces (troy)	0.9115
ounces	tons (long)	$2.790 \times 10^{-5}$
ounces	tons (metric)	$2.835 \times 10^{-5}$
ounces (fluid)	cubic in.	1.805
ounces (fluid)	liters	0.02957
ounces (troy)	grains	480.0
ounces (troy)	grams	31.103481
ounces (troy)	ounces (avdp.)	1.09714
ounces (troy)	pennyweights (troy)	20.0
ounces (troy)	pounds (troy)	0.08333
ounces/sq. in.	dynes/sq. cm	4,309
ounces/sq. in.	pounds/sq. in.	0.0625
parsec	miles	$19 \times 10^{12}$
parsec	kilometers	$3.084 \times 10^{13}$
parts/million	grains/U.S. gal	0.0584
parts/million	grains/Imp. gal	0.07016
parts/million	pounds/million gal	8.345
pecks (British)	cubic in.	554.6
pecks (British)	liters	9.091901
pecks (U.S.)	bushels	0.25
pecks (U.S.)	cubic in.	537.605
pecks (U.S.)	liters	8.809582
pecks (U.S.)	quarts (dry)	8
pennyweights (troy)	grains	24.0
pennyweights (troy)	ounces (troy)	0.05
pennyweights (troy)	grams	1.55517
pennyweights (troy)	pounds (troy)	$4.1667 \times 10^{-3}$
pints (dry)	cubic in.	33.60
pints (liq.)	cubic cm	473.2
pints (liq.)	cubic feet	0.01671
pints (liq.)	cubic in.	28.87
pints (liq.)	cubic meters	$4.732 \times 10^{-4}$
pints (liq.)	cubic yards	$6.189 \times 10^{-4}$
pints (liq.)	gallons	0.125
pints (liq.)	liters	0.4732
pints (liq.)	quarts (liq.)	0.5
Planck's quantum	erg-second	$6.624 \times 10^{-27}$
poise	gram/cm sec	1.00
poundals	dynes	13,826
poundals	grams	14.10
poundals	joules/cm	$1.383 \times 10^{-3}$
poundals	joules/meter (newtons)	0.1383
poundals	kilograms	0.01410
poundals	pounds	0.03108
pound-feet	cm-dynes	$1.356 \times 10^7$
pound-feet	cm-grams	13,825
pound-feet	meter-kg	0.1383
pounds	drams	256
pounds	dynes	$44.4823 \times 10^4$
pounds	grains	7,000
pounds	grams	453.5924

To Convert	Into	Multiply by
pounds	joules/cm	0.04448
pounds	joules/meter (newtons)	4.448
pounds	kilograms	0.4536
pounds	ounces	16.0
pounds	ounces (troy)	14.5833
pounds	poundals	32.17
pounds	pounds (troy)	1.21528
pounds	tons (short)	0.0005
pounds (avdp.)	ounces (troy)	14.5833
pounds (troy)	grains	5,760
pounds (troy)	grams	373.24177
pounds (troy)	ounces (avdp.)	13.1657
pounds (troy)	ounces (troy)	12
pounds (troy)	pennyweights (troy)	240
pounds (troy)	pounds (avdp.)	0.822857
pounds (troy)	tons (long)	$3.6735 \times 10^{-4}$
pounds (troy)	tons (metric)	$3.7324 \times 10^{-4}$
pounds (troy)	tons (short)	$4.1143 \times 10^{-4}$
pounds of water	cubic ft	0.01602
pounds of water	cubic in.	27.68
pounds of water	gallons	0.1198
pounds of water/min	cubic ft/sec	$2.670 \times 10^{-4}$
pounds/cubic ft	grams/cubic cm	0.01602
pounds/cubic ft	kg/cubic meter	16.02
pounds/cubic ft	pounds/cubic in.	$5.787 \times 10^{-4}$
pounds/cubic ft	pounds/mil-foot	$5.456 \times 10^{-9}$
pounds/cubic in.	gm/cubic cm	27.68
pounds/cubic in.	kg/cubic meter	$2.768 \times 10^4$
pounds/cubic in.	pounds/cubic ft	1,728
pounds/cubic in.	pounds/mil-foot	$9.425 \times 10^{-6}$
pounds/ft	kg/meter	1.488
pounds/in.	gm/cm	178.6
pounds/mil-foot	gm/cubic cm	$2.306 \times 10^6$
pounds/sq. ft	atmospheres	$4.725 \times 10^{-4}$
pounds/sq. ft	feet of water	0.01602
pounds/sq. ft	inches of mercury	0.01414
pounds/sq. ft	kg/sq. meter	4.882
pounds/sq. ft	pounds/sq. in.	$6.944 \times 10^{-3}$
pounds/sq. in.	atmospheres	0.06804
pounds/sq. in.	feet of water	2.307
pounds/sq. in.	in. of mercury	2.036
pounds/sq. in.	kg/sq. meter	703.1
pounds/sq. in.	pounds/sq. ft	144
quadrants (angle)	degrees	90
quadrants (angle)	minutes	5,400.0
quadrants (angle)	radians	1.571
quadrants (angle)	seconds	$3.24 \times 10^5$
quarts (dry)	cubic in.	67.20
quarts (liq.)	cubic cm	946.4
quarts (liq.)	cubic feet	0.03342
quarts (liq.)	cubic in.	57.75
quarts (liq.)	cubic meters	$9.464 \times 10^{-4}$
quarts (liq.)	cubic yards	$1.238 \times 10^{-3}$
quarts (liq.)	gallons	0.25
quarts (liq.)	liters	0.9463
radians	degrees	57.30
radians	minutes	3,438
radians	quadrants	0.6366
radians	seconds	$2.063 \times 10^5$

To Convert	Into	Multiply by
radians/sec	degrees/sec	57.30
radians/sec	revolutions/min	9.549
radians/sec	revolutions/sec	0.1592
radians/sec/sec	revolutions/min/min	573.0
radians/sec/sec	revolutions/min/sec	9.549
radians/sec/sec	revolutions/sec/sec	0.1592
revolutions	degrees	360
revolutions	quadrants	4.0
revolutions	radians	6.283
revolutions/min	degrees/sec	6.0
revolutions/min	radians/sec	0.1047
revolutions/min	revolutions/sec	0.01667
revolutions/min/min	radians/sec/sec	$1.745 \times 10^{-3}$
revolutions/min/min	revolutions/min/sec	0.01667
revolutions/min/min	revolutions/sec/sec	$2.778 \times 10^{-4}$
revolutions/sec	degrees/sec	360.0
revolutions/sec	radians/sec	6.283
revolutions/sec	revolutions/min	60
revolutions/sec/sec	radians/sec/sec	6.283
revolutions/sec/sec	revolutions/min/min	3,600
revolutions/sec/sec	revolutions/min/sec	60.0
rod	chain (Gunter's)	0.25
rod	meters	5.029
rods	feet	16.5
rods (surveyors' meas.)	yards	5.5
scruples	grains	20
seconds (angle)	degrees	$2.778 \times 10^{-4}$
seconds (angle)	minutes	0.01667
seconds (angle)	quadrants	$3.087 \times 10^{-6}$
seconds (angle)	radians	$4.848 \times 10^{-6}$
slug	kilogram	14.59
slug	pounds	32.17
sphere	steradians	12.57
square centimeters	circular mils	$1.973 \times 10^5$
square centimeters	sq. feet	$1.076 \times 10^{-3}$
square centimeters	sq. in.	0.1550
square centimeters	sq. meters	0.0001
square centimeters	sq. miles	$3.861 \times 10^{-11}$
square centimeters	sq. millimeters	100.0
square centimeters	sq. yards	$1.196 \times 10^{-4}$
square feet	acres	$2.296 \times 10^{-5}$
square feet	circular mils	$1.833 \times 10^8$
square feet	sq. cm	929.0
square feet	sq. in.	144.0
square feet	sq. meters	0.09290
square feet	sq. miles	$3.587 \times 10^{-8}$
square feet	sq. millimeters	$9.290 \times 10^4$
square feet	sq. yards	0.1111
square in.	circular mils	$1.273 \times 10^6$
square in.	sq. cm	6.452
square in.	sq. feet	$6.944 \times 10^{-3}$
square in.	sq. millimeters	645.2
square in.	sq. mils	$10^6$
square in.	sq. yards	$7.716 \times 10^{-4}$
square kilometers	acres	247.1
square kilometers	sq. cm	$10^{10}$
square kilometers	sq. feet	$10.76 \times 10^6$
square kilometers	sq. in.	$1.550 \times 10^9$
square kilometers	sq. meters	$10^6$



To Convert	Into	Multiply by
square kilometers	sq. miles	0.3861
square kilometers	sq. yards	$1.196 \times 10^6$
square meters	acres	$2.471 \times 10^{-4}$
square meters	sq. cm	$10^4$
square meters	sq. feet	10.76
square meters	sq. in.	1,550
square meters	sq. miles	$3.861 \times 10^{-7}$
square meters	sq. millimeters	$10^6$
square meters	sq. yards	1.196
square miles	acres	640.0
square miles	sq. feet	$27.88 \times 10^6$
square miles	sq. km	2.590
square miles	sq. meters	$2.590 \times 10^6$
square miles	sq. yards	$3.098 \times 10^6$
square millimeters	circular mils	1,973
square millimeters	sq. cm	0.01
square millimeters	sq. feet	$1.076 \times 10^{-5}$
square millimeters	sq. in.	$1.550 \times 10^{-3}$
square mils	circular mils	1.273
square mils	sq. cm	$6.452 \times 10^{-6}$
square mils	sq. in.	$10^{-6}$
square yards	acres	$2.066 \times 10^{-4}$
square yards	sq. cm	8,361
square yards	sq. feet	9.0
square yards	sq. in.	1,296
square yards	sq. meters	0.8361
square yards	sq. miles	$3.228 \times 10^{-7}$
square yards	sq. millimeters	$8.361 \times 10^5$
temperature (°C) + 273	absolute temperature (°C)	1.0
temperature (°C) + 17.78	temperature (°F)	1.8
temperature (°F) + 460	absolute temperature (°F)	1.0
temperature (°F) – 32	temperature (°C)	5/9
tons (long)	kilograms	1,016
tons (long)	pounds	2,240
tons (long)	tons (short)	1.120
tons (metric)	kilograms	1,000
tons (metric)	pounds	2,205
tons (short)	kilograms	907.1848
tons (short)	ounces	32,000
tons (short)	ounces (troy)	29,166.66
tons (short)	pounds	2,000
tons (short)	pounds (troy)	2,430.56
tons (short)	tons (long)	0.89287
tons (short)	tons (metric)	0.9078
tons (short)/sq. ft	kg/sq. meter	9.765
tons (short)/sq. ft	pounds/sq. in.	2,000
tons of water/24 hr	pounds of water/hr	83.333
tons of water/24 hr	gallons/min	0.16643
tons of water/24 hr	cubic ft/hr	1.3349
volt (absolute)	statvolts	0.003336
volts/in.	volts/cm	0.39370
watt-hours	Btu	3.413
watt-hours	ergs	$3.60 \times 10^{10}$
watt-hours	foot-pounds	2,656
watt-hours	gram-calories	859.85
watt-hours	horsepower-hr	$1.341 \times 10^{-3}$
watt-hours	kilogram-calories	0.8605
watt-hours	kilogram-meters	367.2
watt-hours	kilowatt-hr	0.001

To Convert	Into	Multiply by
watts (international)	watts (absolute)	1.0002
watts	Btu/hr	3.4129
watts	Btu/min	0.05688
watts	ergs/sec	107
watts	foot-lb/min	44.27
watts	foot-lb/sec	0.7378
watts	horsepower	$1.341 \times 10^{-3}$
watts	horsepower (metric)	$1.360 \times 10^{-3}$
watts	kg-calories/min	0.01433
watts	kilowatts	0.001
watts (Abs.)	Btu (mean)/min	0.056884
watts (Abs.)	joules/sec	1
webers	maxwells	$10^8$
webers	kilolines	$10^5$
webers/sq. in.	gausses	$1.550 \times 10^7$
webers/sq. in.	lines/sq. in.	$10^8$
webers/sq. in.	webers/sq. cm	0.1550
webers/sq. in.	webers/sq. meter	1,550
webers/sq. meter	gausses	$10^4$
webers/sq. meter	lines/sq. in.	$6.452 \times 10^4$
webers/sq. meter	webers/sq. cm	$10^{-4}$
webers/sq. meter	webers/sq. in.	$6.452 \times 10^{-4}$
yards	centimeters	91.44
yards	kilometers	$9.144 \times 10^{-4}$
yards	meters	0.9144
yards	miles (naut.)	$4.934 \times 10^{-4}$
yards	miles (stat.)	$5.682 \times 10^{-4}$
yards	millimeters	914.4